

HYDRAULIC SCHEMATIC

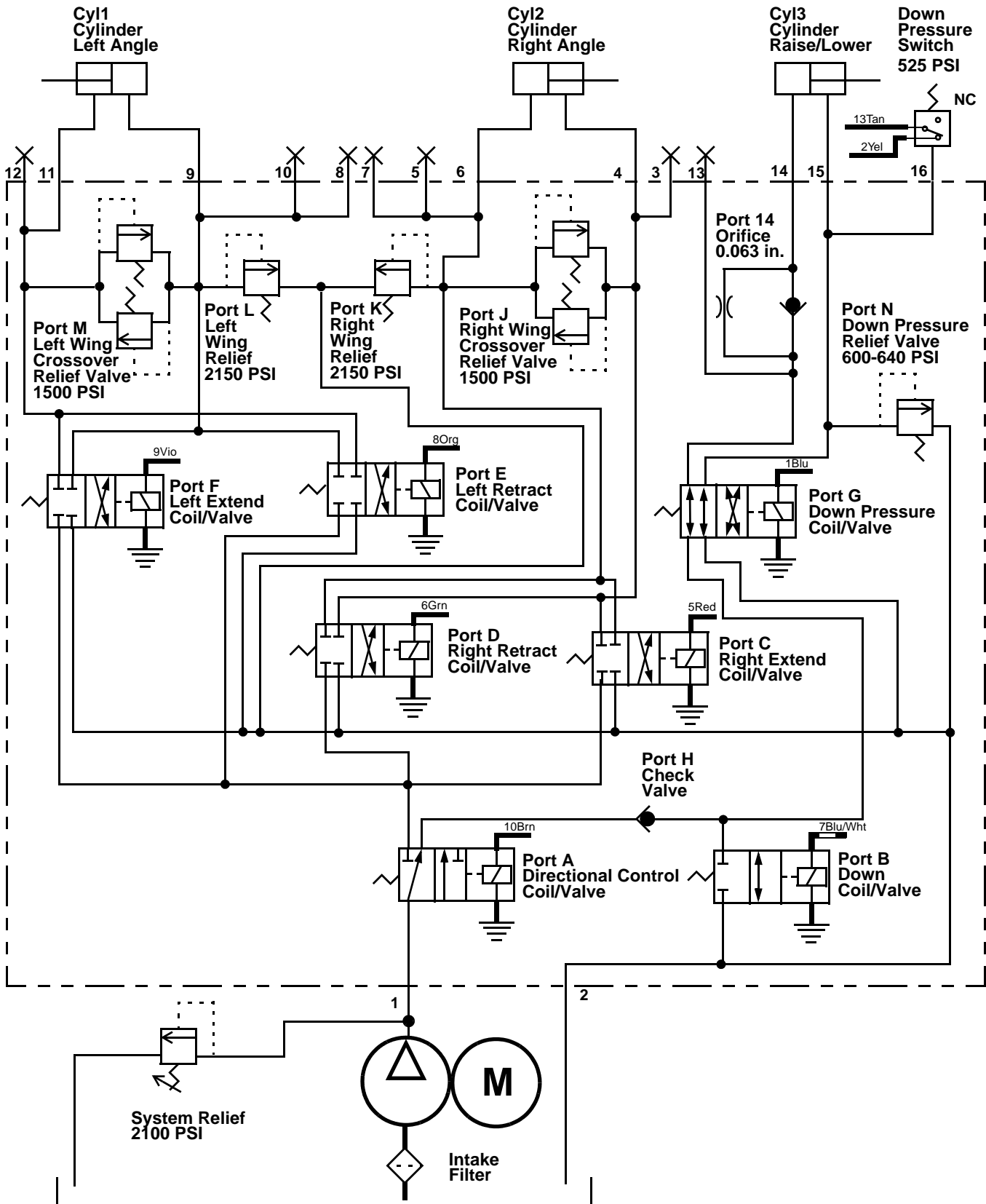

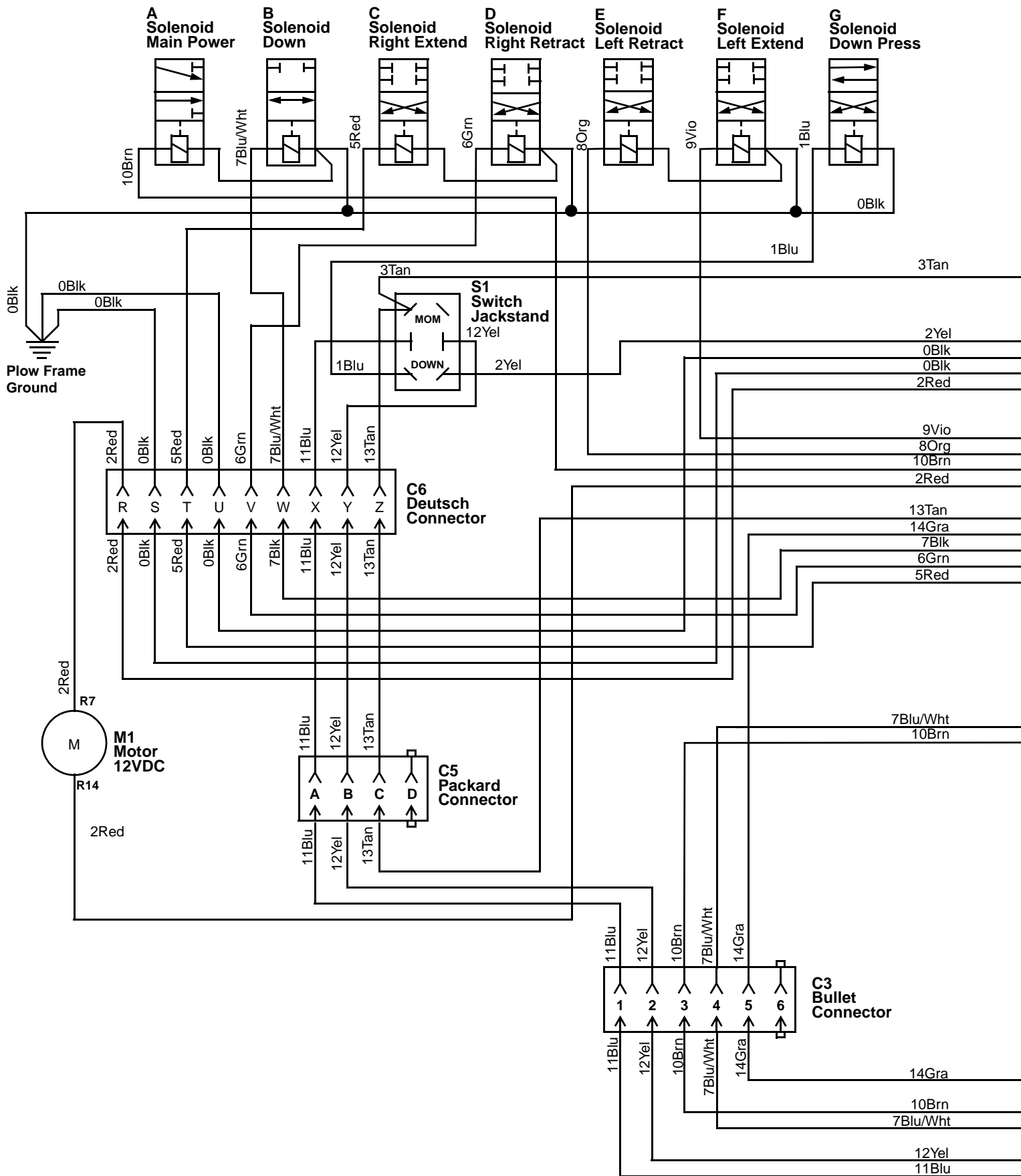

W1 Wire Harness - Vehicle

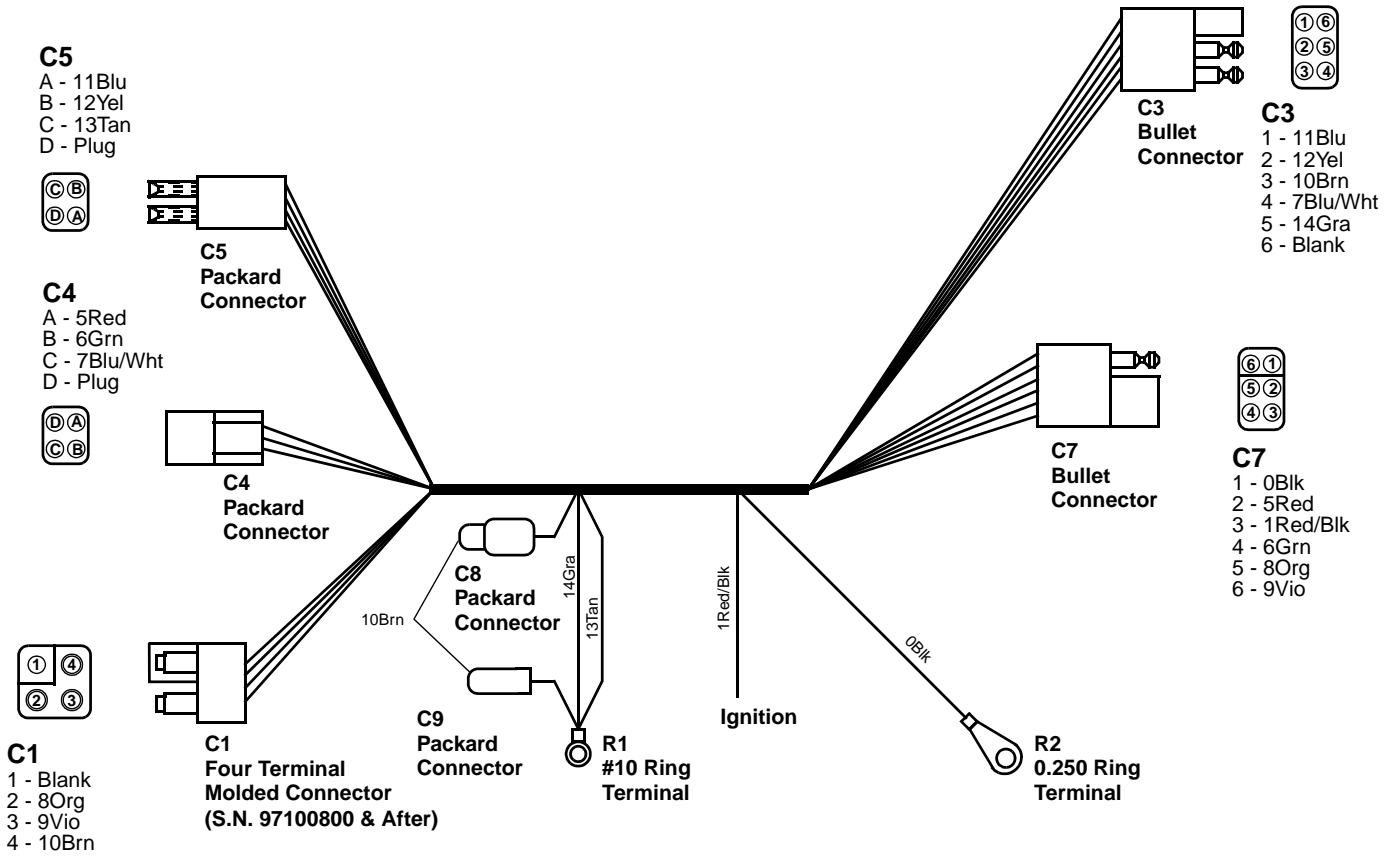

W2 Wire Harness - Control Box "B"

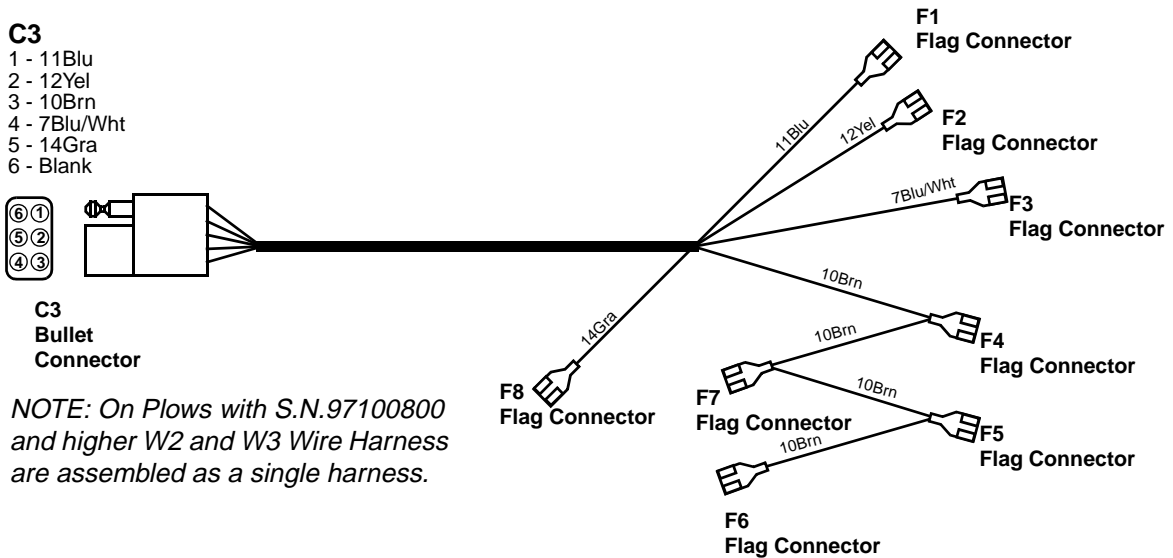

W3 Wire Harness - Control Box "A"

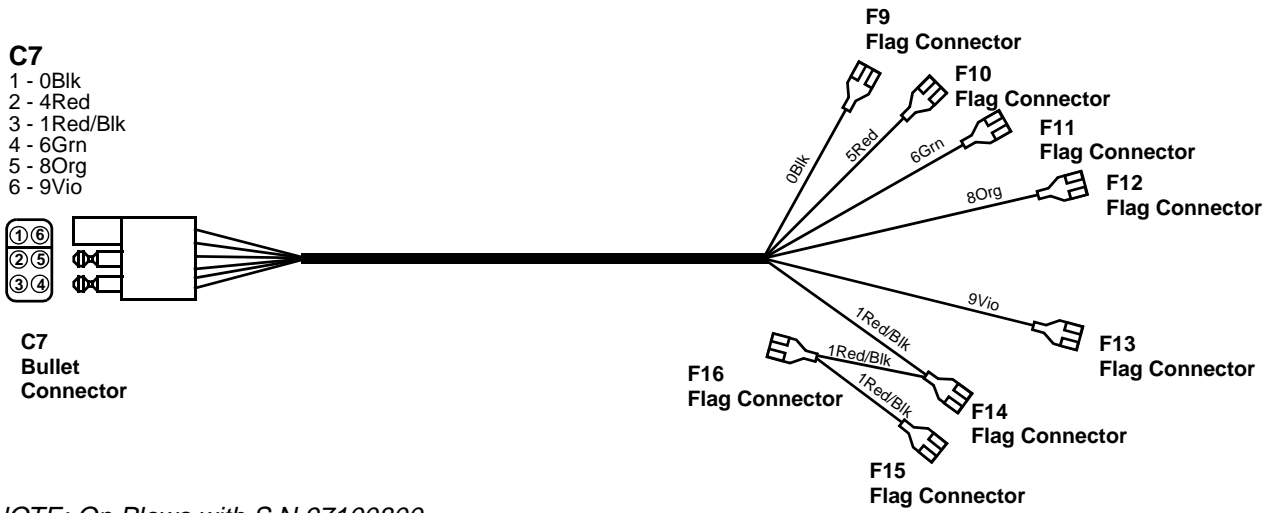

NOTE: On Plows with S.N.97100800 and higher W2 and W3 Wire Harness are assembled as a single harness.

W4 Wire Harness - Vehicle End Control

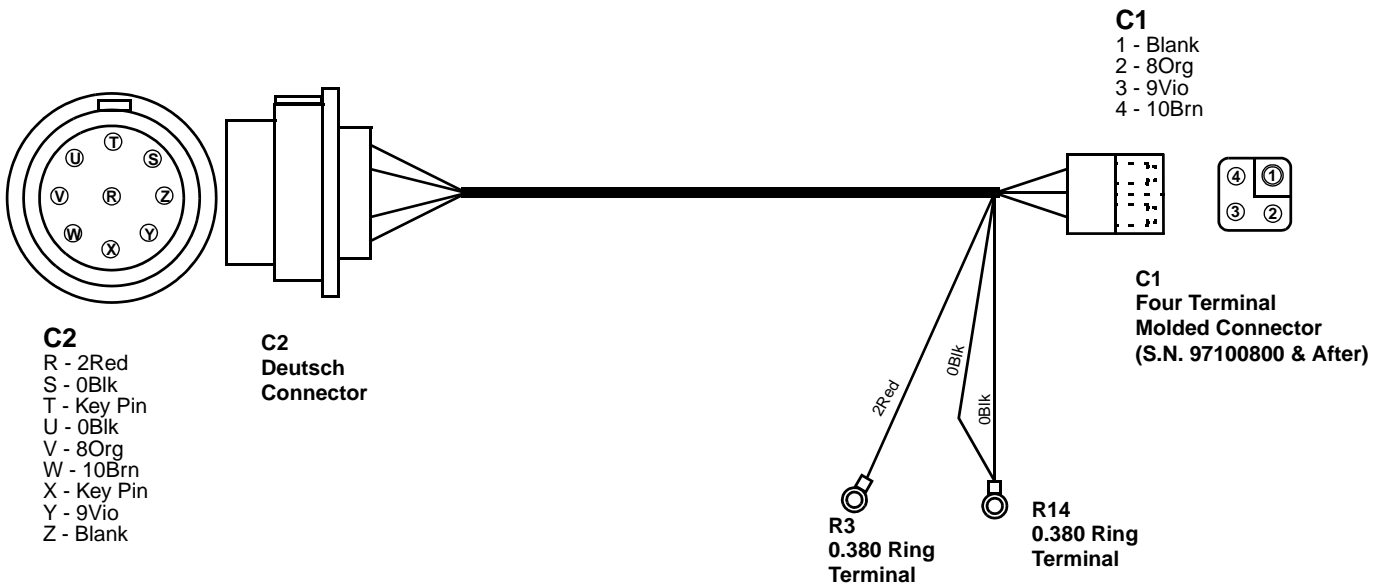

W5 Wire Harness - Vehicle End

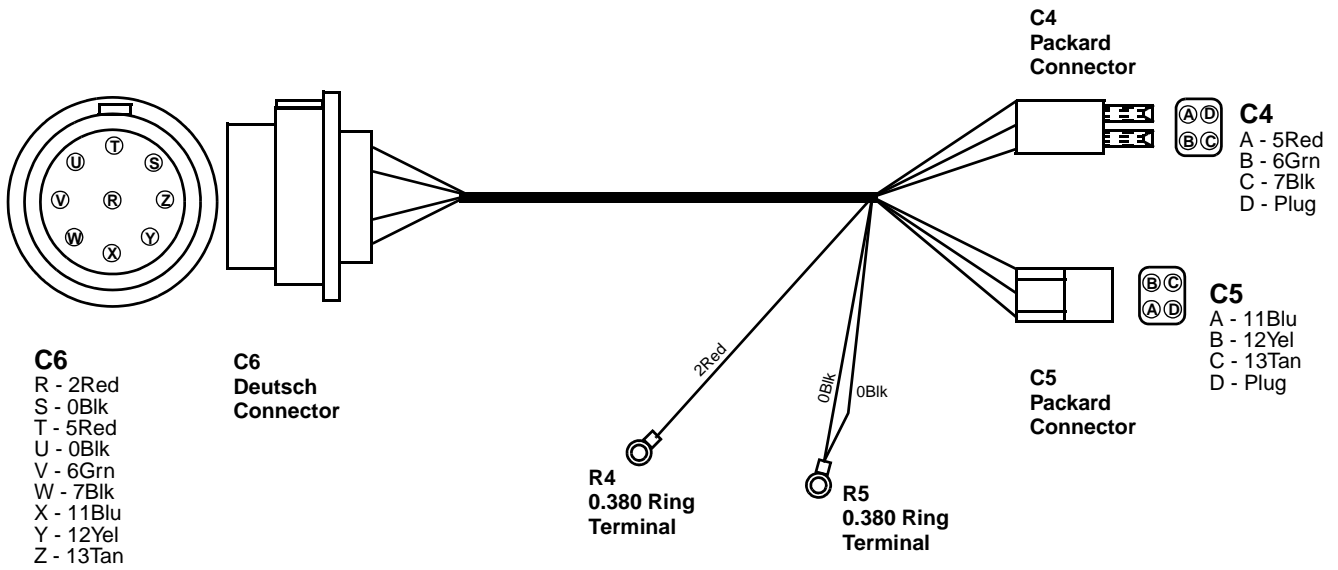

W6 Wire Harness - Pump End Control

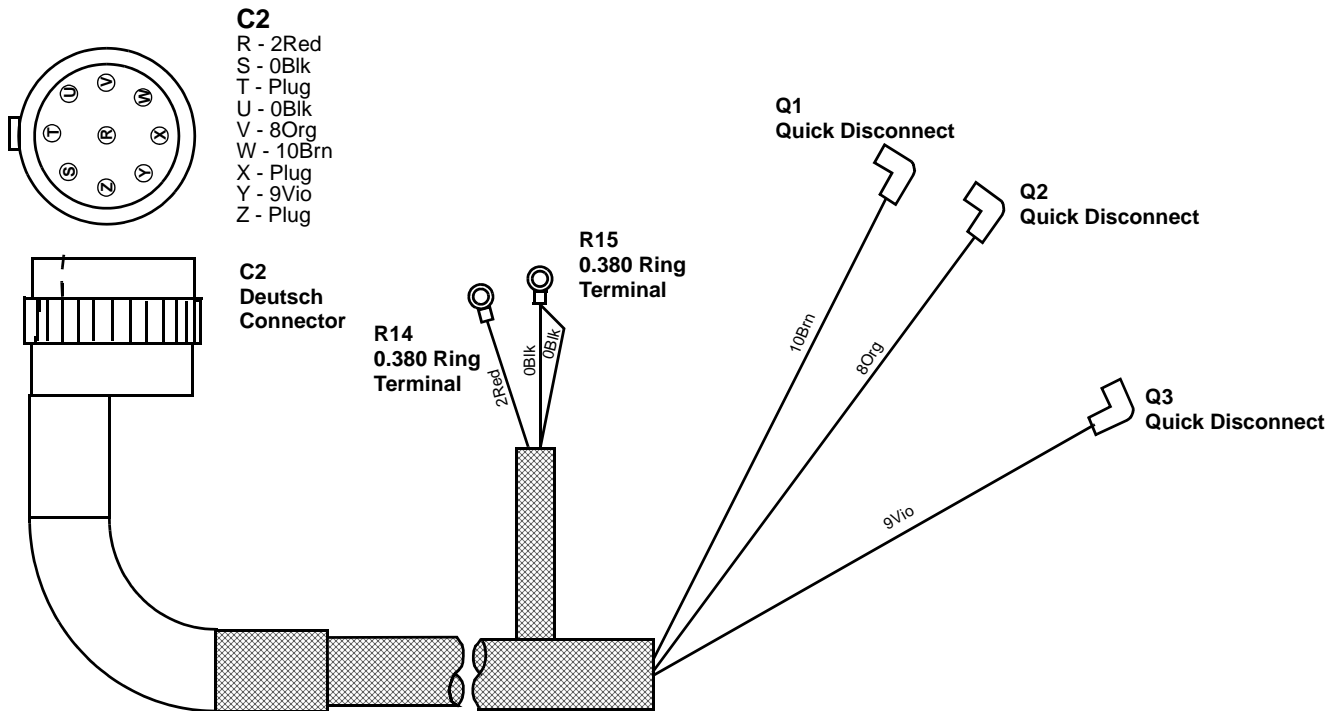

W8 Wire Harness (No Longer Used)

W9 Wire Harness - Battery Power



W10 Wire Harness - Battery Ground

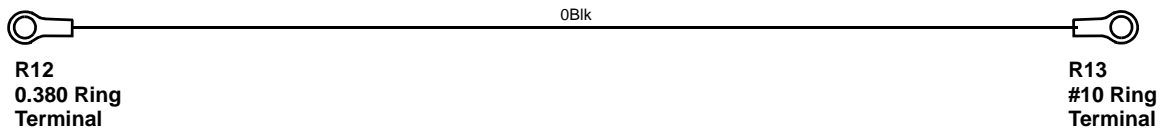

W11 Wire Harness - Solenoid Switch Power

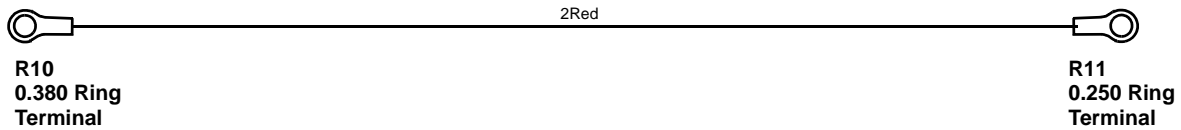

W12 Wire Harness - Jackstand Switch Jumper

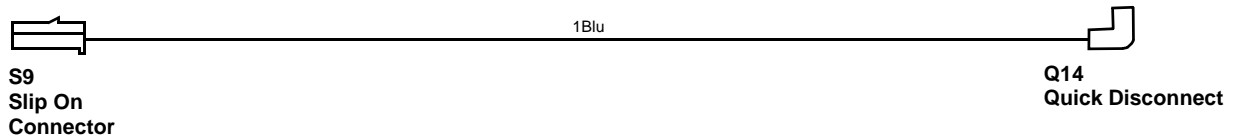

W13 Wire Harness - Jackstand Switch Jumper



W14 Wire Harness - Control Box Jumper (2 Req.)

