

SNO-WAY[®]

SNOW & ICE CONTROL EQUIPMENT

OWNER'S MANUAL

28V SERIES SNOW PLOW WITH EIS

**FOR PLOW SERIAL NUMBERS AFTER
28VG100100
28VD100302**



TABLE OF CONTENTS

	Page
INTRODUCTION	2
SAFETY	3
THEORY OF OPERATION.....	4
Hydraulic Power Unit.....	4
Hydraulic Controls.....	4
Electro-Hydraulic Controls	4
Raise Mode of Operation	4
Lower Mode of Operation - Gravity Down and Float	4
Lower Mode of Operation - Down Pressure (DP) System	4
Wing Angling Mode of Operation - Independent Wing Angling	5
Combination Wing Angling.....	5
Circuit Breaker	5
PLOWING OPERATION.....	6
Operating Classes	6
Before The Season Begins	6
Transporting Vehicle With Blade Attached.....	6
Plowing Like A Pro	7
Using The Down Pressure Hydraulic System	7
Plowing Roadways	7
Clearing Parking Lots.....	7
Mounting Snow Plow To Vehicle	8
Installing The Cylinder Lock Clamp.....	10
Removing Snow Plow From Vehicle	11
Plow Storage	12
TROUBLESHOOTING	13
Introduction	13
Troubleshooting-Quick Reference General	13
TROUBLESHOOTING CHART	14
MAINTENANCE	18
General	18
Periodic Inspection.....	18
Special Fasteners Torques and Requirements	18
Hydraulic Cylinders	19
Electrical Quick Disconnect Plugs.....	19
Service Intervals	19
Fluid Requirements	19
Changing Oil and Cleaning Filter Screen	19
Disk Shoe Adjustment.....	20
Float Limiter Adjustment	22
Pivot Assembly Pivot Screws	23
Cutting Edge	23
Trip Spring Adjustment	24
TORQUE SPECIFICATIONS.....	26
HYDRAULIC SCHEMATIC (GRAVITY)	27
HYDRAULIC SCHEMATIC (DOWN PRESSURE)	28
WIRING SCHEMATIC (GRAVITY)	29
WIRING SCHEMATIC (DOWN PRESSURE).....	30
WARRANTY	Back Cover

INTRODUCTION

This manual was written for the assembly, installation and maintenance of your new Sno-Way plow. Most importantly, this manual provides an operating plan for safe use. Refer to the Table of Contents for an outline of this manual.

Please keep this manual with your machine at all times as reference material and so it can be passed on to the next owner if the machine is sold.

We require that you read and understand the contents of this manual COMPLETELY, especially the chapter on SAFETY, before attempting any procedure contained in this manual.



The Society of Automotive Engineers has adopted this SAFETY ALERT SYMBOL to pinpoint characteristics that, if NOT carefully followed, can create a safety hazard. When you see this symbol in this manual or on the machine itself, BE ALERT!, your personal safety and the safety of others, is involved.

• Defined in the next column, are the SAFETY ALERT messages and how they will appear in this manual.

	<h2>WARNING</h2>
<p>FAILURE TO FOLLOW CAN RESULT IN INJURY OR DEATH.</p>	

	<h2>CAUTION</h2>
<p>Information, that if not carefully followed, can cause injury or damage to equipment!</p>	

NOTE: Additional information concerning the equipment or the procedure that may or may not be contained elsewhere in this manual.

BE AWARE! It is illegal to remove, deface or otherwise alter the safety decals mounted on this equipment.

Record the Power Pack Model Number, Power Pack Serial Number, Controller Serial Numbers, Blade Model Number, Blade Serial Number and the Pump Serial Number in the space provided below as a handy record for quick reference. The Power Pack Serial Number is

located on the A-Frame (near the front on the driver's side), the blade serial number is located on one of the middle ribs of the blade. These plates contain information that your Dealer needs to answer questions or to order replacement parts, if needed, for your unit.

NAME PLATE DATA	
POWER PACK MODEL NUMBER	_____
POWER PACK SERIAL NUMBER <small>(Located on A-Frame)</small>	_____
CONTROLLER SERIAL NUMBERS:	
TRANSMITTER S.N.	_____
RECEIVER S.N.	_____
BLADE MODEL NUMBER	_____
BLADE SERIAL NUMBER <small>(Located on Blade Frame)</small>	_____
PUMP SERIAL NUMBER	_____
(FILL IN)	

DEALER	
NAME	_____
ADDRESS	_____
CITY	_____ STATE _____ ZIP _____
PHONE () -	_____
(FILL IN)	

ORIGINAL PURCHASER	
NAME	_____
ADDRESS	_____
CITY	_____ STATE _____ ZIP _____
PHONE () -	_____
(FILL IN)	

We reserve the right to make changes or improve the design or construction of any part(s) without incurring the obligation to install such parts or make any changes on any unit previously delivered.

Sno-Way Service Parts Manuals are available for purchase from your authorized Sno-Way dealer. Request part number 97100973 for the 28V Series Snow Plows. Factory contact information is available at www.snoway.com.

Snow-Way Products are built under one or more of the following patents:

5,524,368	5,832,637	5,894,688	5,987,785	6,154,986
6,691,435	6,701,646	6,702,208	6,775,933	6,778,932
6,860,039	6,860,040	2,121,948		

SAFETY

BEFORE ATTEMPTING ANY PROCEDURE IN THIS BOOK, READ AND UNDERSTAND ALL THE SAFETY INFORMATION CONTAINED IN THIS SECTION. IN ADDITION, ENSURE ALL INDIVIDUALS WORKING WITH YOU ARE ALSO FAMILIAR WITH THESE SAFETY PRECAUTIONS.

For your safety Warning and Information Decals have been placed on this product to remind the operator to take safety precautions. It is important that these decals are in place and are legible before operation begins. New decals can be obtained from Sno-Way or your local dealer.

REMEMBER The careful operator is the best operator. Most accidents are caused by human error. Certain precautions must be observed to prevent the possibility of injury to operator or bystanders and/or damage to equipment.

NEVER operate Plow when under the influence of alcohol, drugs or other medications that could hamper your judgement and reactions. An accident may result in serious injury or death to other persons or yourself.

ALWAYS operate vehicle in a well-ventilated area. The carbon monoxide in exhaust gas is highly toxic and can cause serious injury or death.

NEVER allow hands, hair or clothing to get near any moving parts such as fan blades, belts and pulleys. Never wear neckties or loose clothing when working on the vehicle.

NEVER wear wrist watches, rings or other jewelry when working on the vehicle or individual equipment. These things can catch on moving parts or cause an electrical short circuit that could result in serious personal injury.

ALWAYS wear safety goggles when working on the vehicle to protect your eyes from battery acid, gasoline, and dust or dirt from flying off of moving engine parts.

ALWAYS be aware of and avoid contact with hot surfaces such as engine, radiator, and hoses.

ALWAYS wear safety glasses with side shields when striking metal against metal! In addition, it is recommended that a softer (non-chipable) metal material be used to cushion the blow. Failure to heed could result in serious injury to the eye(s) or other parts of the body.

NEVER allow children or unauthorized person to operate this unit.

NEVER exceed 45 m.p.h. when snow plow is attached to vehicle. Braking distances may be increased and handling characteristics may be impaired at speeds above 45 m.p.h.

ALWAYS lock the vehicle when unattended to prevent unauthorized operation of the plow.

ALWAYS check the job site for terrain hazards, obstructions and people.

NEVER exceed 10 m.p.h. when plowing. Excessive speed may cause serious injury and damage of equipment and property if an unseen obstacle is

encountered while plowing.

ALWAYS position blade so it does not block path of headlamps beam. Do not change blade positions while traveling. An incorrect plow position blocking headlamp beam may result in an accident.

ALWAYS check surrounding area for hazardous obstacles before operating this unit.

ALWAYS inspect the unit periodically for defects. Parts that are broken, missing or plainly worn must be replaced immediately. The unit, or any part of it should not be altered without prior written approval of the manufacturer.

ALWAYS insert the cylinder lock when plow is not in use. If the cylinder lock is not installed, the plow blade could inadvertently drop and cause serious injury.

ALWAYS shut off the vehicle engine, place the transmission in Neutral or Park, turn the ignition switch to the "OFF" position and firmly apply the parking brake of the vehicle before attaching or detaching the blade from the vehicle or when making adjustments to the blade.

ALWAYS inspect lift system bolts and pins whenever attaching or detaching the plow, and before traveling. Worn or damaged components could result in the plow dropping to the pavement while driving, causing an accident.

ALWAYS keep hands and feet clear of blade and A-Frame when attaching or detaching plow.

NEVER place fingers in A-frame or mount lug holes to check alignment when attaching snow plow. Sudden motion of the plow could severely injure a finger.

NEVER stand between the vehicle and blade or directly in front of blade when it is being raised, lowered or angled. Clearance between vehicle and blade decreases as blade is operated and serious injury or death can result from blade striking a body or dropping on hands or feet.

NEVER work on the vehicle without having a fully serviced fire extinguisher available. A 5 lb or larger CO² or dry chemical unit specified for gasoline, chemical or electrical fires, is recommended.

NEVER smoke while working on the vehicle. Gasoline and battery acid vapors are extremely flammable and explosive.

NEVER use your hands to search for hydraulic fluid leaks; escaping fluid under pressure can be invisible and can penetrate the skin and cause a serious injury! If any fluid is injected into the skin, see a doctor at once! Injected fluid **MUST BE** surgically removed by a doctor familiar with this type of injury or gangrene may result.

REMEMBER it is the owner's responsibility for communicating information on the safe use and proper maintenance of this machine.

THEORY OF OPERATION

Hydraulic Power Unit

The hydraulic power unit consists of:

- 12VDC Motor
- Hydraulic pump rated at 1.54 GPM @ 1500 PSI
- 1.35 quart capacity reservoir
- Fine mesh intake filter
- Filter screens on all outlet ports

The fluid supply line for the pump is submerged in the hydraulic fluid reservoir and is equipped with a fine mesh intake filter screen.

The 12VDC motor is protected electrically by a 150 Amp circuit breaker located between the battery and the motor solenoid.

The hydraulic pump is protected by a 2100 PSI system relief valve.

This unit may be equipped with a Down Pressure Option which will allow the operator to selectively switch the system to provide additional hydraulic force to the cutting edge of the plow.

IMPORTANT: The electric coils, which operate the solenoid valves, require a minimum of 9-1/2 volts DC for proper operation. Lower voltage will cause erratic operation, or failure to operate.

Hydraulic Controls

The hydraulic controls consist of:

- System pressure relief valve, set to 2100 PSI.
- Two crossover relief valves, set to 1750 PSI.
- Two wing relief valves, set to 2150 PSI.
- Four three-way two position hydraulic valves and four pilot operated check valves for wing angling functions.
- Two double acting hydraulic cylinders for wing angling functions.
- One three-way two position, three two-way two position valves and two check valves for raise, lower and down pressure functions.
- One down pressure relief valve.

Electro-Hydraulic Controls

All hydraulic functions are controlled by the 12VDC electrical system which actuates coils on the hydraulic valves and the solenoid for the electric motor of the power unit. 12VDC power is fed from the battery post of the motor start solenoid to a control circuit board on the plow and from the circuit board to each coil. Each valve is actuated by completing a circuit to ground through the coil, and through the circuit board by means of a wire transmitted signal to the circuit board from the hand-held controller in the vehicle.

Raise Mode of Operation

Actuating the 'Raise' switch on the hand-held controller sends a signal to the control circuit board on the plow which then actuates the motor solenoid and the coils for the 'C' valve and 'F' valve. Actuating the start solenoid sends current to the power unit motor to cause the power unit to pump hydraulic fluid. Hydraulic fluid, under pressure, is directed through the 'C' valve to the lift cylinder causing it to extend and raise the plow. The 'F' valve is also actuated to allow fluid in the rod end of the double acting raise cylinder to return to the reservoir. When the 'Raise' switch on the hand-held controller is released the start solenoid circuit is broken and the motor stops, the circuit to the coil for the 'C' valve and the 'F' valve is broken and these valves go to their normally closed positions.

Lower Mode of Operation - Gravity Down and Float

Actuating the 'Lower' switch on the hand-held controller sends a signal to the control circuit board on the plow which then actuates the coil for the 'B' valve and the 'F' valve allowing hydraulic fluid to flow from the lift cylinder to the reservoir. Once the 'Lower' switch has been actuated, the system will stay in this mode until the raise function is actuated, allowing hydraulic fluid to flow between the reservoir and the lift cylinder and let the lift cylinder extend and retract as necessary to follow ground contours while plowing.

Lower Mode of Operation - Down Pressure (DP) System

This system operates only when the 'DP' switch and the 'Lower' switch on the hand-held controller is actuated. Actuating the 'DP' switch (a red LED will be lit) actuates the pressure switch, the 'B' valve coil, the 'E' valve coil and, through the pressure switch, the start solenoid as required. When the 'E' valve is actuated and the hydraulic pump operates, hydraulic fluid is directed to the rod end of the lift cylinder compressing the cylinder and forcing the plow down. The pressure switch in this system senses the pressure of the fluid in the lift cylinder and closes when the pressure becomes low, allowing the motor and the pump to pump fluid into the rod end of the cylinder. When the pressure reaches the proper level, the switch opens, shutting off the motor and pump. The system is protected by a relief valve which relieves excess pressure if the plow is forced up, such as by a bump or obstacle in the roadway. Once any obstacle is cleared, the plow can return to a lower position lowering the pressure in the system. If the pressure is lowered sufficiently, the pressure switch will then sense the lowered pressure and cause the pump to pump fluid into the system and return it to the proper pressure.

The down pressure system is overridden any time the plow control is placed in the 'Raise' mode, but will resume when placed back into the 'Lower' position.

Also, note that the 'E' valve is deactivated anytime an angle function is activated, but returns to its previous condition as soon as the angle function is completed.

Wing Angling Mode of Operation

Independent Wing Angling

Each wing can be angled forward or rearward independently by operating the forward or rearward switch for either the right or left wing.

Operating the right extend switch on the controller will energize the motor solenoid and the 'A' coil, which will allow hydraulic oil under pressure to be directed to the base end of the right wing cylinder. Operating the right retract switch on the controller will energize the motor solenoid and the 'D' coil, which will allow hydraulic fluid under pressure to be directed to the rod end of the right wing cylinder. Operating the left wing extend switch will perform the same function as the right except that the 'G' coil will be energized instead of the 'A' coil. Operating the left retract switch will perform the same function as the right retract except that the 'H' coil will be energized instead of the 'D' coil.

Combination Wing Angling

Both wings can be moved together using the control switches on the controller. Operating the forward combination switch on the controller will extend both wings in the 'scoop' position. Operating this combination will energize the motor solenoid and both the 'A' and 'G' coils.

Operating the rearward combination switch on the controller will retract both wings into the 'V' position. Operating this combination switch will energize the motor solenoid and both the 'D' and 'H' coils.

Operating the right side combination switch on the controller will extend the left wing and retract the right wing to plow all snow to the right. Operating this combination switch will energize the motor solenoid and both the 'D' and 'G' coils.

Operating the left side combination switch on the controller will extend the right wing and retract the left wing to plow all snow to the left. Operating this combination switch will energize the motor solenoid and both the 'A' and 'H' coils.

Each wing angling circuit is protected by a crossover relief valve set to relieve pressure on the wing angling circuit at 1750 PSI. Each wing also has a relief valve set at 2150 PSI.

Circuit Breaker

A 150 Amp circuit breaker is located near the battery in the primary 12VDC positive power circuit and is in place to protect the motor of the hydraulic power unit. A high amp draw condition will cause the breaker element in the circuit breaker to interrupt flow to the motor. The circuit breaker will automatically reset after it cools down.

PLOWING OPERATION

Operating Classes

28V Series

The 28V Series Sno-Way plow is specifically designed for heavy duty snow plowing with full size 3/4 and 1 ton 4x4's.

NOTE: The loaded vehicle, including any ballast weight and optional equipment, must not exceed the Gross Vehicle Weight (GVW) or front or rear Gross Axle Weight (GAW) ratings specified on the Safety Compliance Certification Label located on the driver's side door opening.

NOTE: All vehicles that are equipped with Sno-Way snow plows should be equipped with all vehicle manufacturer's recommended options for snow plowing.

For additional information, refer to your dealer and the Sno-Way Application Guide for proper vehicle applications.

Before The Season Begins

1. Inspect vehicle safety equipment for proper operation; brakes, headlights, plowing lights, windshield wipers, flashers, etc.

2. Inspect the plow, plow frame and all attaching hardware for wear and corrosion. Replace worn or damaged parts and clean and repaint exposed metal parts with a high quality, corrosion resistant enamel.

3. Inspect all fasteners to insure that they are properly tightened. If any fasteners are loose, re-tighten to the proper torque (refer to the Torque Specification Chart in this manual) and carefully inspect the adjacent area for damage or wear as well as carefully inspecting all adjacent fasteners for proper torque.

4. Apply a small amount of light oil to the hitch pins and pivots, to pivot pins between the A-frame and center blade assembly, between lift and swing cylinder pivot pins and the lift linkage pivots.

5. Check the wing pivots for free movement of the wings on the pivot shafts. Lubricate the wing pivot shafts with a good quality light weight HP Lithium based grease.

6. For extremely cold weather plowing, continuous sub zero operation, an alternative is to remove the grease fittings and fill the grease cavity with SAE 140 gear oil, and then replace the grease fitting.

7. Check the reservoir oil level (see maintenance instructions) and repair any oil leaks and worn hoses.

8. Inspect electrical connectors. Make sure the contacts are clean, and apply a small amount of dielectric grease.

9. Install plow lights and ensure they are aimed properly (with plow in full UP position).

10. If ballast is required position ballast behind rear wheels for optimum performance.

Transporting Vehicle With Blade Attached

	WARNING
<p>Ensure ignition switch is OFF before installing or removing the cylinder lock clamp. Equipment failure or inadvertent operation of the control switches could allow the plow blade to fall, resulting in serious injury.</p>	
<p>FAILURE TO FOLLOW CAN RESULT IN INJURY OR DEATH.</p>	

1. Always install the cylinder lock clamp when the plow blade is raised and the operator is not engaged in plowing operations.

NOTE: If cylinder lock clamp is not installed during transport equipment failure or inadvertent operation of the control switches while driving could allow the plow blade to fall.

2. Always transport the plow with the wings fully folded to the rear to keep the transport width to a minimum.

	CAUTION
<p>Remove the plow when driving extended distances at temperatures above 40° F, the plow blocks enough airflow to the vehicle's radiator to cause it to overheat at temperatures above 40° F.</p>	

3. DO Not exceed 45 m.p.h. when driving with the snow plow attached. Braking distance is increased and handling is impaired dramatically at speeds above 45 m.p.h.

4. Reduce speed when crossing railroad tracks or when road conditions deteriorate.

5. Never change blade angle or height while driving.

6. Position the blade out of the beam path of the headlights before driving.

7. Inspect plow and plow attaching hardware for wear or damage before transporting and beginning plow operations.

Plowing Like A Pro



WARNING

- **Never exceed 10 m.p.h. when plowing! Serious personal injury can result, as well as damage to equipment and property, if an unseen obstruction is encountered while plowing.**
- **Never plow with your head protruding from the vehicle side window. Serious head or neck injuries can result from sudden stops or coming into contact with tree branches, signs or other stationary objects.**

FAILURE TO FOLLOW CAN RESULT IN INJURY OR DEATH.



WARNING

Wear your seat belt! Contact with a hidden obstruction can cause serious personal injury from bodily contact within the vehicle cab or whiplash from sudden stops.

FAILURE TO FOLLOW CAN RESULT IN INJURY OR DEATH.

NOTE: The vehicle air bag is factory set to deploy at a pre-determined level of impact. The air bag will deploy with the plow attached if an obstruction is hit with enough force to reach this level. Always plow within the recommended plowing speeds and know the area you are plowing to avoid any obstructions.

1. Become familiar with the area to be plowed and mark potential hazards before the snow falls. Many immovable objects cannot be seen when covered with snow. Developing a plan early can save valuable time and equipment damage. Allow sufficient room to pile snow, out of the traffic area, with enough space for snow when the next storm comes.

2. Plow with the storm. The "Pros" are out early removing only several inches of snow at a time. Allowing snow to accumulate to unmanageable levels can cause difficult removal problems and can be costly in terms of "wear and tear" on equipment. The plow is not a "Ram or Bulldozer", if used properly, it will give you many years of safe and reliable service.

3. Research municipal ordinances for restrictions on the disposal of snow. Many municipalities do not allow snow to be placed in roads or throughway.

Using The Down Pressure Hydraulic System

The Down Pressure System was designed for removing hard packed snow from hard surfaces that have had traffic on them prior to being plowed.

The system should be turned OFF when plowing surfaces such as gravel, dirt, sand, etc., to prevent cutting into the surface being plowed.

Activating the system applies hydraulic pressure to the down side of the hydraulic lift cylinder. This down pressure will force the blade through the hard-packed snow and down to the pavement. If down pressure decreases, (results if a valley or low spot is encountered by the blade), more down pressure is applied to lower side of the lift cylinder and the blade will follow the contour of the valley. When a hill or a high spot is encountered by the blade, the down pressure will be relieved on the down side of the lift cylinder, this will allow the blade to follow the contour of the hill without lifting the front of the vehicle off the ground.

Plowing Roadways

A roadway covered with unpacked snow that is not over 4-6" deep can be plowed by angling the plow wings to move the snow all to one side.

If the roadway is covered with deep and/or hard packed snow, position the plow wings in a "V"-position to move snow equally to each side to open the first path through the roadway. The roadway can then be widened by making successive passes on each side of the first path, with the wings angled to move snow to one side.

Clearing Parking Lots

1. Plow a single path, with the plow in a "V" position, through the lot at right angle to the side of the lot where you want to "stack" the snow.

2. With the plow angled to one side, widen the path until the snow piled to the side of the path is large enough for a full "scoop" to be moved to the edge of the lot for stacking.

3. With the blade in "scoop" position, push the snow plowed to the edge of the path to the edge of the lot and "stack" it in a pile.

4. If the snow plowed to the edge of the path is too large to push the entire pile to the edge of the lot, fill the blade, in "scoop" position, and then push the pile over into the cleared path and then to the edge of the lot. Then return, and with the blade in "scoop" position, push the remaining row of plowed snow to the edge of the lot.

5. When "stacking" snow, pushing the plow filled with snow into the existing pile will usually cause the plow to raise somewhat as it goes into the pile allowing the "stack" to be built higher.

6. If the snow in the lot is deep and/or hard packed, plow all the paths through the lot with the blades in the "V" position. This will put less sideload on the vehicle and will make plowing the paths easier.

Mounting Snow Plow To Vehicle

1. Drive truck into plow. Align light/lift bar frame inside of sub-frame lugs. Pins should fit inside slots cut into sub-frame lugs. (See Figure 1-1).

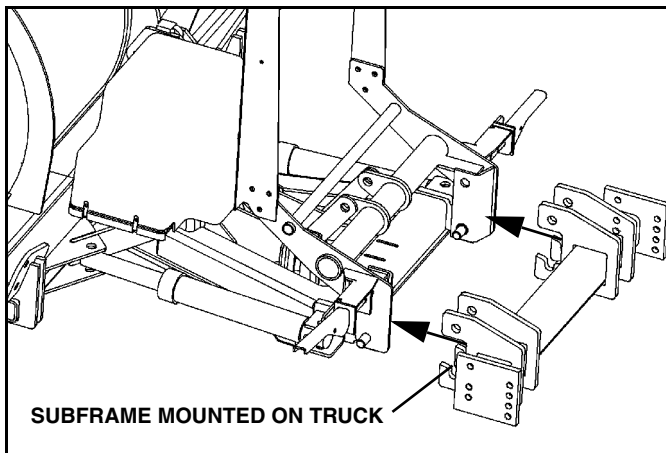

Figure 1-1

*NOTE: If pins are too high or low to fit into slots on sub-frame, adjust the height by plugging in the plow and hand held controller. **For Down Pressure Plows** - To lower the pins, turn on down pressure and press down. To raise the pins, press up. **For Gravity Plows** - To lower the pins, place plow in float and push up on light bar. To raise the pins, press up.*



WARNING

When using the hand held controller to raise or lower the plow A-frame for mounting the plow to the vehicle, be especially careful of the movement of the light bar. This movement will occur when raising or lowering the A-frame or jack stand.

FAILURE TO FOLLOW CAN RESULT IN INJURY OR DEATH



WARNING

Pressing the blade angle functions will result in the A-frame swinging if it is not secured to the truck. Do not press the angle function during plow installation.

FAILURE TO FOLLOW CAN RESULT IN INJURY OR DEATH

2. Plug in power harness and remove controller from truck cab. Plug controller into plow.



WARNING

The power cable in front of the truck is wired directly to the battery. The power cable is always energized, even if the truck is turned off. Always replace the protective cap after disconnecting the plow power cable. Allowing an unprotected plug to contact metal parts of the truck may cause electrical component damage. Never use a metal object to clean the plug contacts.

FAILURE TO FOLLOW CAN RESULT IN INJURY OR DEATH

3. Rotate light/lift bar into position by turning on down pressure and pressing the lower button. (See Figure 1-2).

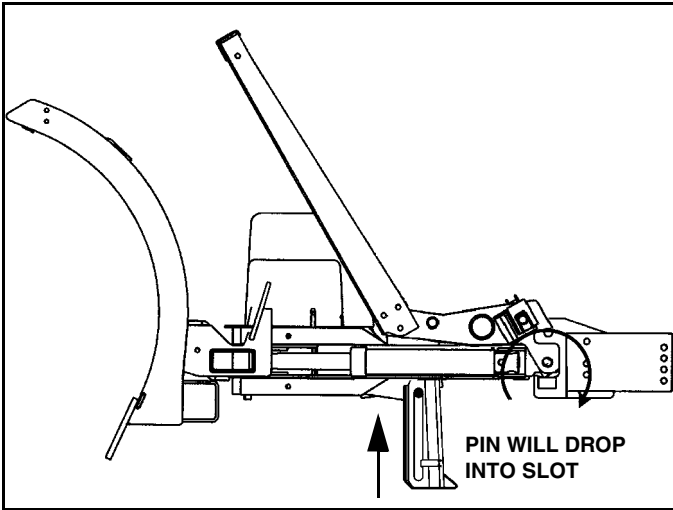

Figure 1-2

NOTE: If your plow is not equipped with down pressure hydraulics you will have to manually rotate the light lift bar into position by placing plow in float mode and pushing on the light bar.

4. Put plow into float position by turning down pressure off. Rotate pin handles down to lock pins in place. (See Figure 1-3).

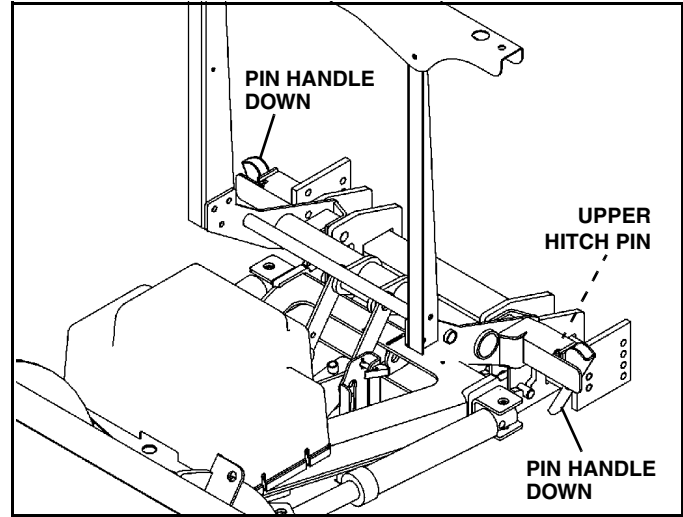

Figure 1-3

5. Unplug plow from control.

6. Disengage both jack stand pins by pulling on handles. Raise the jack stand and engage the bottom pin by pushing on the handle. Make sure pin is engaged in hole by rotating jack stand back and forth. (See Figure 1-4).

WARNING

Make sure that upper hitch pins are engaged before moving truck. Hitch pins not fully engaged could result in the plow separating from the truck.

FAILURE TO FOLLOW CAN RESULT IN INJURY OR DEATH

NOTE: Upper hitch pins are fully engaged when pin handle is tight against pin bracket and you cannot see the upper hitch pin between the pin bracket and pin handle. If upper hitch pins are not fully engaged:
 A. Raise plow an inch off the ground, then lower. Or,
 B. Turn Down Pressure ON and then OFF.
 Upper hitch pins will snap into place.

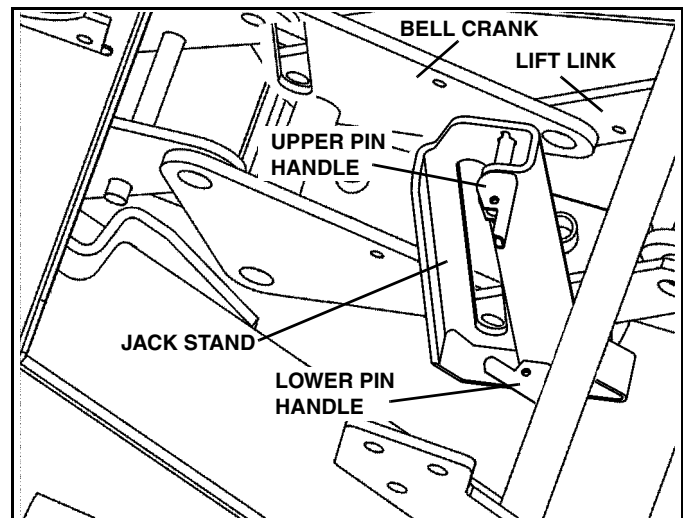

Figure 1-4

7. Unplug light harness connectors on truck, and disconnect plow light connectors, which had been plugged together for corrosion protection during storage (See Figure 1-5).

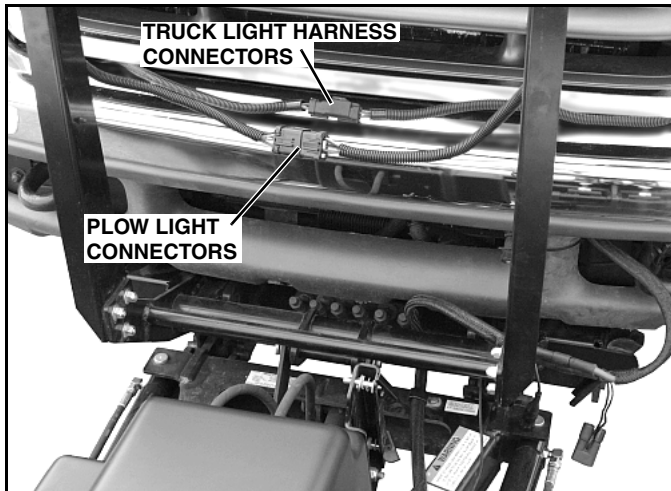

Figure 1-5

8. Plug plow light connectors into mating connectors on truck light harness (See Figure 1-6).

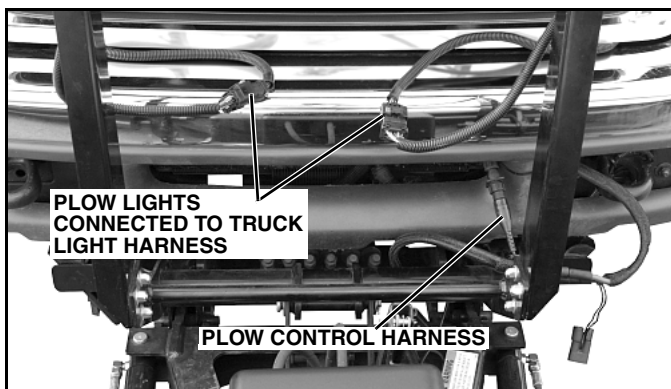

Figure 1-6



WARNING

Failure to properly connect plow lights to vehicle light harness will prevent plow lights from functioning. Follow proper procedure to connect light harnesses and test lights before operating.

FAILURE TO FOLLOW CAN RESULT IN INJURY OR DEATH

9. Plug control harness on plow into truck. Plug plow control inside truck cab.
10. Raise, lower and angle plow to make sure no hoses or wires pinch in the plow mechanism.

Installing The Cylinder Lock Clamp



WARNING

Always install the cylinder lock clamp when the plow blade is raised and the operator is not engaged in plowing operations. Equipment failure or inadvertent operation of the plow control while driving could allow the plow blade to fall, resulting in injury.

FAILURE TO FOLLOW CAN RESULT IN INJURY OR DEATH

1. Raise the plow to the full UP position.
2. Turn the ignition OFF and apply the parking brake.
3. Turn OFF the hand-held controller.
4. Remove the pin from the cylinder lock clamp.
5. Position the cylinder lock clamp around the exposed (chrome) portion of the lift cylinder with the open side of the cylinder lock up. Install the pin. (See Figure 1-7).

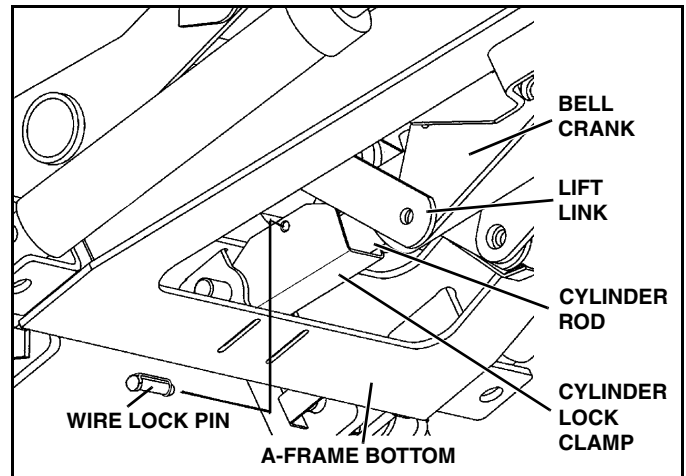

Figure 1-7

6. Lower the plow so that cylinder lock clamp is tight against cylinder.



WARNING

Failure to lower plow onto clamp could block headlights resulting in an accident.

FAILURE TO FOLLOW CAN RESULT IN INJURY OR DEATH

Removing Snow Plow From Vehicle

Choose a location for the plow storage, which will allow the plow to be removed from the vehicle and not be moved after removal. Also, choose a location that will not allow the plow stand to sink into the ground. A dry, protected area is recommended.

1. Lower plow to the ground, put vehicle in park, turn off the engine and set the parking brake.
2. Disconnect the plow lights from the truck light harness (See Figure 1-8). Disconnect the plow control harness and replace the protective cap.

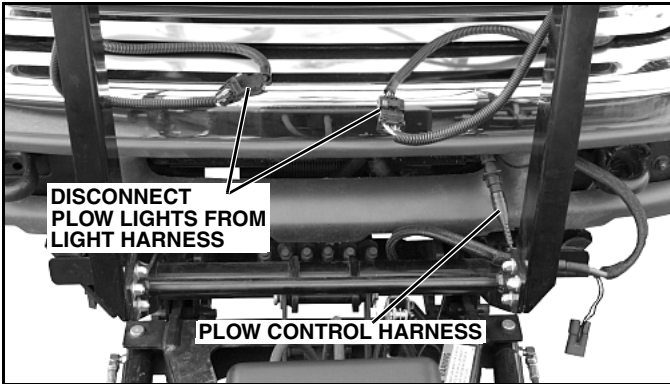

Figure 1-8

3. To prevent corrosion on the contacts, plug the male and female connectors on the plow together (See Figure 1-9).
4. To make the truck lights operable, plug the male and female connectors on the truck light harness together (See Figure 1-9).

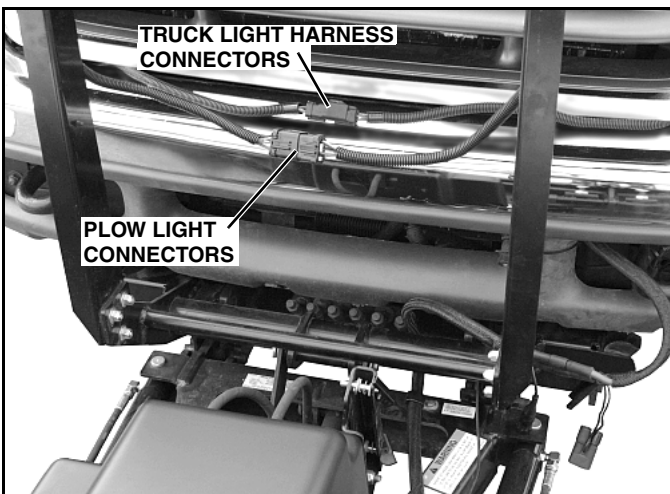

Figure 1-9



WARNING

Failure to reconnect the main light harness on the truck when removing plow will cause truck lights to not operate, which could cause an accident. Test lights before operating.

FAILURE TO FOLLOW CAN RESULT IN INJURY OR DEATH



CAUTION

When disconnecting the plow control harness, turn only the locking nut at the end of the connector. Do not turn the threaded boot. Turning the threaded boot will break the wires in the harness and cause the controller to stop functioning. (See Figure 1-10).

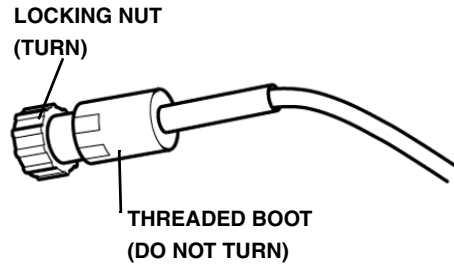

Figure 1-10

5. Turn Down Pressure ON and then OFF.
6. Rotate pin handles up (straight out) to unlock main pins. (See Figure 1-11).

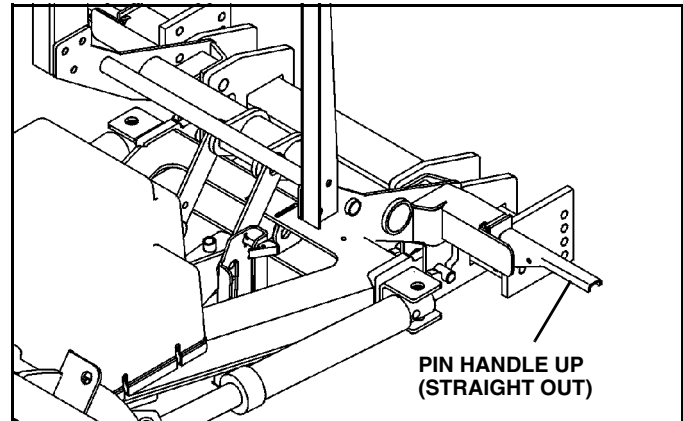

Figure 1-11

7. Disengage lower jack stand pin by pulling on handle. Lower the jack stand and engage the top pin by pushing on the handle. Make sure pin is engaged in hole by rotating jack stand back and forth.

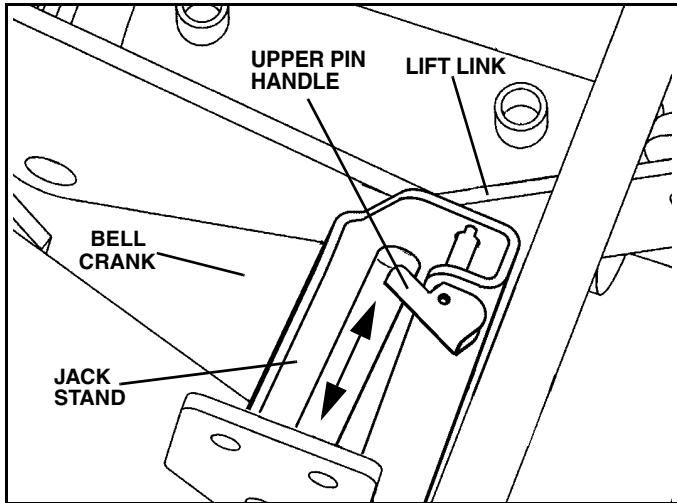

Figure 1-12

8. Remove controller from truck cab and plug into plow control harness.

9. Rotate jack stand down and raise A-frame by pressing the up button. (See Figure 1-13).

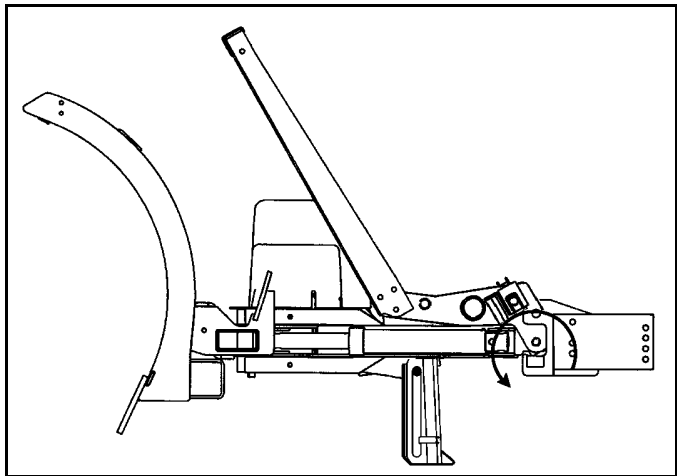

Figure 1-13

10. Disconnect power harness, replace protective caps and back truck away from plow.

Plow Storage

1. If the plow will not be stored on a firm surface (i.e. concrete or asphalt), place a board or piece of plywood, etc. under the jackstand to prevent the jackstand foot from sinking into the ground.

2. To avoid corrosion during storage, coat the exposed (chrome) portion of the lift and angle cylinders with a light grease.

3. Grease all pivot points.

4. Top off hydraulic reservoir to minimize trapped air.

5. Make sure that protective caps are on all electrical connections. Apply a small amount of dielectric grease to ensure a moisture proof seal on the caps.

6. Check and replace any worn and/or damaged component, such as cutting edges or deflectors. Performing preventative maintenance tasks in the spring when plow is stored will ensure that you will be ready to plow in the fall.

TROUBLESHOOTING

Introduction

Whenever service is necessary, your local dealer knows your plow best and is interested in your complete satisfaction. Return your snow plow to your local dealer for maintenance service or any other assistance you may require. If you are unable to do so, this Trouble Shooting Guide should help you determine the problem. Also, there are Repair Manuals available from your local dealer. However, before attempting the servicing of your plow, you should possess good mechanical abilities and a total understanding of the mechanism.

5. Check the voltage at the coils which operate the solenoid valves to be sure that the voltage at the coils is a minimum of 9-1/2 volts DC.



CAUTION

First read all warning instruction, the safety messages, and directions before attempting any adjustments or repairs to your unit!

PLEASE: Before calling parts and service personnel be certain that:

1. You have read this guide carefully and are certain that all of the suggestions pertaining to your problem have been attempted.
2. You have the following information available.
 - A. Date Snow Plow was originally installed.
 - B. Power Pack Model Number.
 - C. Power Pack Serial Number.
 - D. Controller Serial Number.
 - E. Blade Model Number.
 - F. Blade Serial Number.
 - G. Pump Serial Number.

This information should be recorded on page 2 of this Owners Manual.

Troubleshooting-Quick Reference General

1. Check to see that controller is "on".
2. Check all wiring to be sure that battery terminals are clean and connections to battery, circuit breaker, solenoid, switches and all connectors on plow harness are clean and tight.
3. Check oil level in hydraulic system reservoir.
4. Check for external leakage at cylinders, hoses and power unit.

TROUBLESHOOTING CHART

PROBLEM	PROBABLE CAUSE	CORRECTIVE ACTION
Plow will not lift (Motor runs)	Hydraulic fluid level low	See Maintenance Section
	Defective Control Unit	Refer to Dealer
	Improper main pressure relief valve pressure setting, debris causing valve to stick	Refer to Dealer
	Breather cap plugged	See Maintenance Section
	Faulty raise or raise/float solenoid coil	Refer to Dealer
	Raise/lower solenoid valve stuck in lower position	Refer to Dealer
	Raise/lower cylinder frozen or binding	Refer to Dealer
	Defective or sticking Down Pressure Solenoid Valve	Refer to Dealer
	Pick-up tube filter plugged	See Maintenance Section
	Pick-up tube is not submerged in fluid	See Maintenance Section
	Machine failure	Refer to Dealer
	Weak battery and/or charging system	Refer to Dealer
Motor continues to run and will not shut-off	Motor Solenoid defective	Refer to Dealer
	Electrical short	Refer to Dealer
Plow lifts slowly	Hydraulic fluid level low	See Maintenance Section
	Breather cap plugged	See Maintenance Section
	Improper main relief pressure setting, debris causing valve to stick	Refer to Dealer
	Pick-up tube filter plugged	See Maintenance Section
	Improper oil viscosity for outside air temperature, unit not at normal operating temperature	See Maintenance Section
	Defective Lift Cylinder	Refer to Dealer
	Machine failure	Refer to Dealer

PROBLEM	PROBABLE CAUSE	CORRECTIVE ACTION
Fluid leaking at Pump Assembly	Hydraulic fittings not torqued properly (too tight, too loose)	Refer to Dealer
	O-Rings between valve block and endhead are cut or not seating properly	Refer to Dealer
	O-Rings between endhead and reservoir cut or not seating properly	Refer to Dealer
	Reservoir over-full	See Maintenance Section
	O-Ring on solenoids or pressure switches defective	Refer to Dealer
	Endhead cracked	Refer to Dealer
	Valve body cracked	Refer to Dealer
Unit lifts but does not hold - first action	Dirt in check valve or Float/DP solenoid valve	Cycle raise and lower system to flush debris
	Float/DP solenoid valve sticking	Cycle raise and lower system to un-stick valve
Unit lifts but does not hold - second action	Dirt or debris in check valve	Refer to Dealer
	Check valve spring broken	Refer to Dealer
	Float/DP solenoid valve sticking	Refer to Dealer
	Seals O-Ring(s) on Float/DP solenoid valve damaged	Refer to Dealer
	Raise/lower ram defective	Refer to Dealer
	Machine failure	Refer to Dealer
Unit will not lower <i>NOTE: Only in non- down pressure mode</i>	Plugged breather cap	See Maintenance Section
	Low or no current available at Float/DP Solenoid	Refer to Dealer
	Float/DP solenoid valve sticking	Refer to Dealer
	Float/DP solenoid coil defective	Refer to Dealer
	Raise lower ram defective allowing movement in one direction only	Refer to Dealer
	Machine failure	Refer to Dealer

PROBLEM	PROBABLE CAUSE	CORRECTIVE ACTION
Unit will not lower <i>NOTE: In down pressure mode only</i>	See all above conditions	Refer to Dealer
	Raise lower ram defective allowing movement in one direction only	Refer to Dealer
	Defective Control Unit	Refer to Dealer
	Defective down pressure solenoid	Refer to Dealer
	Machine failure	Refer to Dealer
Motor will not run	Motor brushes worn/commutator worn or dirty	Refer to Dealer
	Seal between motor and pump defective allowing oil to enter motor housing	Refer to Dealer
	Defective Start Solenoid	Refer to Dealer
	Motor seized	Refer to Dealer
	Machine failure	Refer to Dealer
Blade wing moves in one direction only	Solenoid valve sticking or defective	Refer to Dealer
	Crossover relief valve defective or sticking	Refer to Dealer
	Low or no current available at extend or retract solenoid valve	Refer to Dealer
	Angle cylinder defective allowing movement in one direction only	Refer to Dealer
	Machine failure	Refer to Dealer
Blade wing will not move	Hydraulic fluid level low	See Maintenance Section
	Crossover pressure relief valve setting too low	Refer to Dealer
	Solenoid valve sticking or defective	Refer to Dealer
	Low or no current available at solenoid valve	Refer to Dealer
	Wing cylinder binding or frozen	Refer to Dealer
	Pick up tube not submerged in fluid	See Maintenance Section
	Machine failure	Refer to Dealer
Blade wing will not move, but plow raises when trying to move wings	Raise solenoid valve defective or sticking	Refer to Dealer

PROBLEM	PROBABLE CAUSE	CORRECTIVE ACTION
Blade wing moves very slowly	Hydraulic fluid level low	See Maintenance Section
	Crossover Relief Valve defective or sticking	Refer to Dealer
	Improper oil viscosity for outside air temperature, unit not at normal operating temperature	See Maintenance Section
	Defective Wing Cylinder	Refer to Dealer
	Dirt or debris in Solenoid Valve	Refer to Dealer
Blade wings will not hold position (fold rearward)	Defective or dirt/debris in Wing Relief Valve	Refer to Dealer
	Defective or sticking Solenoid Valve	Refer to Dealer
	Dirt or debris in Solenoid Valve	Refer to Dealer
	Defective Wing Cylinder	Refer to Dealer

MAINTENANCE

General



WARNING

Before servicing plow, lower plow to the ground or onto cylinder lock clamp and disconnect main power harness.

FAILURE TO FOLLOW CAN RESULT IN INJURY OR DEATH

- Before operating, perform a thorough visual inspection of the equipment. Look for fluid leaks, cracked, bent or broken components, loose nuts, bolts or attachments and proper fluid levels.
- A clean hydraulic system is essential to long pump life and proper performance.
- When adding oil to the reservoir, wipe the area around the filler port clean before removing the breather cap. Use clean oil and a clean funnel, (DO NOT use a cloth or rag to strain the oil).

IMPORTANT: Hydraulic unit comes from factory charged with Type 5606. If additional oil is added it must be compatible with Type 5606. If another type of oil has been used in the system the same type of oil must be used for topping off system. Improper hydraulic fluid can cause operating problems in cold weather.

- The operational environment for snow plows is an extremely harsh and corrosive one.
- Ensure all electrical connections are clean and tight.
- To prevent rust from forming, clean and repaint exposed metal surfaces.
- NEVER operate the equipment with the protective covers or guards removed.

Periodic Inspection

After approximately every 20 hours of operation perform the following inspections procedures:

1. Inspect the plow assembly including the sub-frame assembly for any damage or excessive wear. Also inspect all fasteners to insure that they are properly tightened. If any fasteners are loose re-tighten to the proper torque (Refer to the Torque Specification Chart in this manual). Also carefully inspect adjacent area for damage or wear as well as carefully inspecting all adjacent fasteners for proper torque.

2. Apply a small amount of light oil to the hitch pins and pivots, to pivot pins between the center blade assembly and the intermediate pivot assembly, between lift and swing cylinder pivot pins and the lift linkage pivots.

3. Lubricate the wing pivot shafts with a good quality HP Lithium based grease.

NOTE: For extremely cold weather plowing, continuous sub zero operation, an alternative is to remove the grease fittings and fill the grease cavity with SAE 140 gear oil, and then replace the grease fitting.

Special Fasteners Torques and Requirements

IMPORTANT: Incorrectly securing fasteners may result in incorrect operation, excessive wear, and early failure of plow components. It may also void your warranty.

- ALWAYS check to make sure you are using the correct torque specification for the fastener you are using.
- DO NOT use any lubricants on the threads of any fastener unless specifically called for in the assembly or maintenance story for that component.
- NEVER use liquid locking materials, such as Loctite™ or Threadmaker™, on any fasteners unless specifically called for in an assembly or maintenance story for that component.

Standard Fasteners:

The Torque Specifications Chart on page 26 of this manual should be used as the guide for fastener torque requirements for most standard fasteners used on the plow.

Standard fasteners with special torque requirements will be noted in assembly or service stories pertaining to the specific piece of equipment.

Hydraulic Fittings:

Hydraulic fittings with lock nuts should be assembled with at least three full turns of the fitting in the port and then the lock nut should be tightened to 27 lb-ft.

Wing Cylinder Attaching Fasteners:

Base end and rod end attachment cap screws are always assembled with the cap screw head UP.

Always use a nylock nut and only torque the nut to 25 to 30 lb-ft. DO NOT overtighten these fasteners. Overtightening of wing cylinder attachment fasteners may bind cylinder and cause excessive cylinder wear and/or restrict wing movement.

Bellcrank Assembly to Lift Arm Assembly Fasteners:

Apply Loctite 242™ (Blue) to the threads of the cap

screws and tighten the jam nut to 70 lb-ft. Then place the lock nut on the cap screw and tighten to 70 lb-ft.

Pivot Frame Assembly:

Install the 1" slotted nut on the threaded end of the special screw and tighten finger tight. Then tighten the nut another 2/3 to 1 full turn and line up a slot in the nut with the cross hole in the special screw. Install the 3/16"x2" cotter pin in the special screw and spread the ends of the cotter pin.

Hydraulic Cylinders

To avoid corrosion during storage, coat the exposed (chrome) portion of the lift and angle cylinders with a light grease.

Electrical Quick Disconnect Plugs

Install protective caps or plug together quick disconnect ends to prevent corrosion from forming on terminal ends during storage or when plow is disconnected from vehicle.

Service Intervals

It is recommended to change the fluid in the hydraulic system once a season.

Fluid Requirements

IMPORTANT: Hydraulic unit comes from factory filled with Type 5606. If additional oil is added it must be compatible with Type 5606.

NOTE: when Type 5606 is not available Exxon UNIVIS J13 or equivalent may be used.



CAUTION

- Using the proper oil increases the life expectancy of the most critical part of your plow; the Hydraulic power unit.
- Failure to use the proper oil can cause extensive damage to the power unit, seals and hydraulic rams.
- Improper oil can cause operating problems and poor performance in cold weather.

Changing Oil and Cleaning Filter Screen



CAUTION

Using the proper oil increases the life expectancy of the most critical part of your unit; the Hydraulic power unit.

NOTE: We recommend cleaning the filter screen at every oil change, this will help ensure maximum life and maximum performance from the pump assembly.



WARNING

- Allow the system to cool down before draining oil or handling system components. Serious burns can result from contact with hot oil.
- Never disconnect any hydraulic line or fitting with the unit in the raised position. Always lower the unit and relieve pressure before removing any lines or caps.

FAILURE TO HEED CAN RESULT IN INJURY OR DEATH.

1. Lower plow assembly to ground, put vehicle in park and turn off engine. Turn hand-held controller off.



WARNING

Ensure engine is OFF and set parking brake before working on plow. Vehicle movement, equipment failure or inadvertent operation of the control switches during maintenance could result in serious injury

FAILURE TO HEED CAN RESULT IN INJURY OR DEATH.

2. Remove two (2) self-tapping screws from the front of the cover and loosen two (2) cap screws from the rear. Remove the cover.

3. Remove the filler/breather cap from the reservoir. (See Figure 2-14).

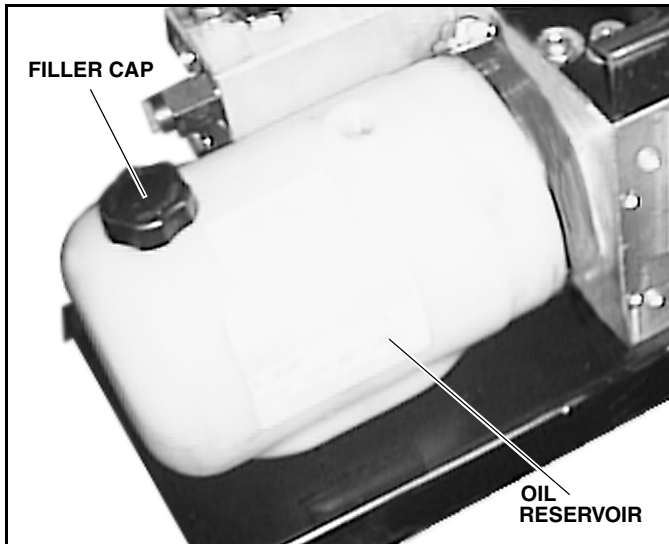

Figure 2-14

4. Using an oil suction gun or similar tool, remove the oil from the oil reservoir.

NOTE: Be careful to avoid contacting and damaging the filter screen while removing the oil.

5. Loosen the clamp securing the oil reservoir to the pump assembly and remove the oil reservoir being careful not to damage the filter screen while removing the oil reservoir. (See Figure 2-14).

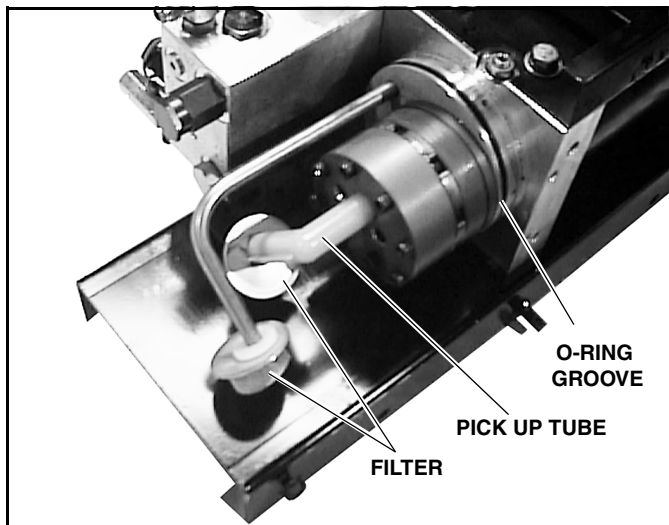

Figure 2-15

6. Pull the filter screens off the return and suction tubes (hold it by the metal cover, not by the screen) and clean with a suitable solvent. Blow dry with low pressure compressed air from the inside.

7. Carefully reinstall the filter screens.

8. Visually check that the pickup tube and filter face down. (See Figure 2-15). If not, rotate the pickup tube until the tube and filter face down.

9. Clean the oil reservoir inside and out with a suitable solvent.

10. Inspect the o-ring seal for damage, replace if needed, lubricate with fresh oil and reinstall reservoir carefully to avoid damaging the O-ring.

11. Mark hydraulic fittings for position and location on both angle and lift cylinders and carefully disconnect them.

12. Manually work the two angle and lift cylinders through their entire range of motion in order to drain the fluid remaining in the cylinders.

13. Reconnect hydraulic fittings in their correct position and torque to 20-25 lb-ft. If unit utilizes o-ring and jam nut type connectors tighten jam nut to 15-20 lb-ft.



CAUTION

Do Not use Teflon® tape or pipe compound on hydraulic fittings. These can dislodge and jam valves in the hydraulic system.

14. Fill the hydraulic oil reservoir until the fluid level registers full on oil level mark on oil reservoir.

NOTE: Vehicle must be parked on level ground, Plow must be in the lowered position, and Wings must be folded rearward ("V") in order to properly check the oil level. Checking oil level with plow elevated or with wings straight or folded forward will give wrong reading.

15. Refer to plow operation instructions and operate the plow to purge all air from the hydraulic system.

16. Replenish the fluid in the reservoir until the fluid level registers full on oil level mark on oil reservoir.

17. Operate system and check for leaks, repair or tighten as necessary.

Disk Shoe Adjustment

IMPORTANT: This plow is equipped with three (3) disk shoes. Two disk shoes are located at the outboard end of each wing. The third disk shoe is located under the trip springs on the center plow assembly. All three disk shoes must be adjusted equally.

IMPORTANT: To ensure the best function of this snow plow, it is a requirement that all three disk shoes be used at ALL times.

1. Drive the vehicle, with snow plow mounted, onto a smooth, level surface. Park the vehicle, move the plow wings until the wings are in the scoop position on each side and lower the plow to the ground.

2. Turn ignition switch OFF and apply the emergency brake. Turn hand-held controller off.

3. Inspect both float limiter screws and be sure that the hex head of the screws are not contacting the wear plate underneath the hex head of the screw. If necessary, adjust each screw upward so that the screw head is not contacting the wear plate when the pivot tubes are vertical.

NOTE: After disk shoe adjustment is completed, the float limiter adjustment must be made. See "Float Limiter Adjustment" on page 22.

4. Place a level against the front of the wing pivot tubes and pull or push the top of the center section until the level indicates that the pivot tubes are vertical (Not tipped either forward or rearward).

5. Determine whether the center disk shoe or the center wearstrip is off the ground and measure the amount that it is off the ground. (See Figure 2-16).

NOTE: Wing shoes must not be holding wear strips off the ground.

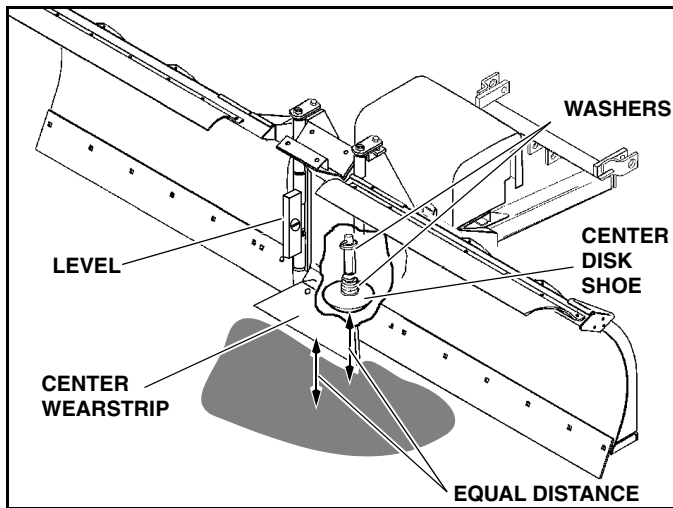

Figure 2-16

NOTE: Gap may be measured by sliding shims or washers between the ground and/or the center disk shoe or the center wearstrip, then measuring the shim/washer stack. The center disk shoe will need to be adjusted until the disk shoe and center wearstrip both contact the ground at the same time.

If the center disk shoe was off the ground - washers must be **ADDED** below the disk shoe mounting tube.
If the center wearstrip was off the ground - washers must be **REMOVED** from below the disk shoe mounting tube.

IMPORTANT: If washers must be added, add one washer LESS than the amount the disk shoe was off the ground. If washers must be removed, remove one washer MORE than the amount the wearstrip was off the ground.

6. Raise plow and place suitable blocking under the plow to allow at least eight inches (8") of clearance from the bottom of the center disk shoe to the ground.

7. Lower plow onto blocking.

**WARNING**

Keep hands and feet clear of wings and center section when setting blocking and lowering plow. Moving or falling assemblies could result in serious injury.

FAILURE TO HEED CAN RESULT IN INJURY OR DEATH.

8. Adjust center disk shoe assembly by removing the disk shoe mounting pin and adding or subtracting washers on the top or bottom of the disk shoe mounting bracket as required according to measurements taken in step #4.

9. After the center disk shoe position is properly adjusted, place washers on the disk shoe stem - above the disk shoe mounting bracket, and below the retaining pin - to remove all up and down movement of the disk shoe in the bracket. Failure to do this will result in excessive wear of the holes in the disk shoe mounting bracket and will also result in bending the disk shoe stem.

10. After the center disk shoe adjustment is completed, lower the plow to the ground. If this disk shoe adjustment is correct, the center disk shoe and the center wearstrip will both be on the ground and the wing tubes will be vertical (Recheck the wing tubes with a level). If wing tubes are not vertical, repeat steps #3 to #9 until wing tubes are vertical.

NOTE: If assembling and mounting a snow plow for the first time, the adjustment of the center disk shoe can be done with just the center section mounted on the vehicle, prior to assembling the wings onto the center section of the plow.

11. With each wing extended straight out to each side, measure the amount the wing shoes are off the ground, or if they are on the ground, measure the amount that the wearstrip is off the ground (measured in front of the disk shoe bracket).

12. Raise plow and place suitable blocking under the plow to allow at least six inches (6") of clearance from the bottom of the wing disk shoes to the ground.

13. Lower plow onto blocking.

 **WARNING**

Keep hands and feet clear of wings and center section when setting blocking and lowering plow. Moving or falling assemblies could result in serious injury.

FAILURE TO HEED CAN RESULT IN INJURY OR DEATH.

14. Adjust each disk shoe assembly by removing disk shoe mounting pin and adding or subtracting washers on the top or bottom of the disk shoe mounting bracket as required according to measurements taken in step #11 (See Figure 2-17).

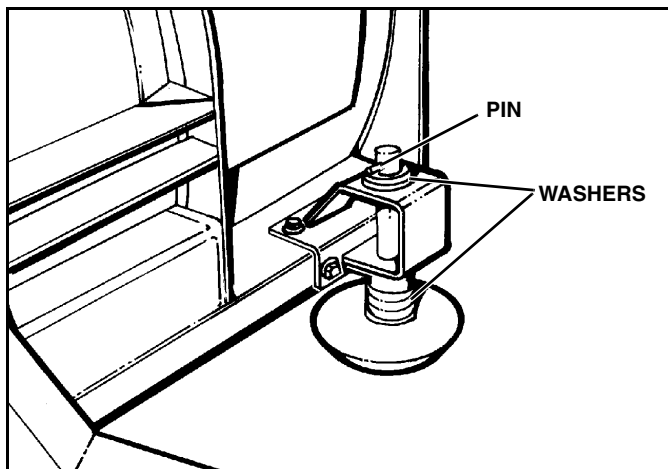

Figure 2-17

15. After the disk shoe position is properly adjusted, place washers on the disk shoe stem - above the disk shoe mounting bracket, and below the retaining pin - to remove all up and down movement of the disk shoe in the bracket. Failure to do this will result in excessive wear of the holes in the disk shoe mounting bracket and will also result in bending the stem of the disk shoe.

16. After the wing disk shoe adjustment is complete, lower the plow to the ground. If this disk shoe adjustment is correct, the shoes and the wearstrips will all be on the ground at the same time, if not, repeat steps #11 to #15.

17. Move the wings forward and rearward. If the wing wearstrips and the center wearstrips are not on the ground at all times recheck the position of the wing pivot tubes. The tubes must be vertical, if they are not vertical, the center disk shoe will need to be adjusted.

Float Limiter Adjustment

IMPORTANT: The disk shoes must be properly adjusted prior to adjusting the float limiter. If the shoes are not properly adjusted, the float limiter adjustment cannot be properly made.

1. With the vehicle and snow plow on a smooth, level surface move the wings forward into the "scoop" position and lower the plow to the ground.

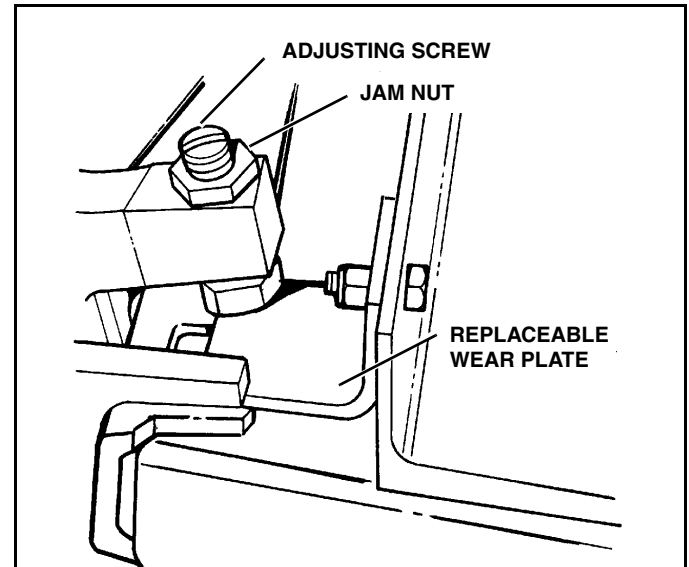

Figure 2-18

2. Loosen the 5/8" jam nut on the top of the float limiter adjusting screw.

3. Using the screwdriver slot in the top of the float limiter adjusting screw, turn the adjusting screw down until the hex head of the adjusting screw touches the surface of the replaceable wear plate.

4. Turn the adjusting screw up two turns to provide a gap between the wear plate and the head of the adjusting screw for proper float allowance.

5. While holding the adjusting screw driver slot, to prevent turning of the adjusting screw, tighten the 5/8" jam nut to lock the adjusting screw and prevent turning of the adjusting screw during operation.

6. Repeat on other side.

Pivot Assembly Pivot Screws

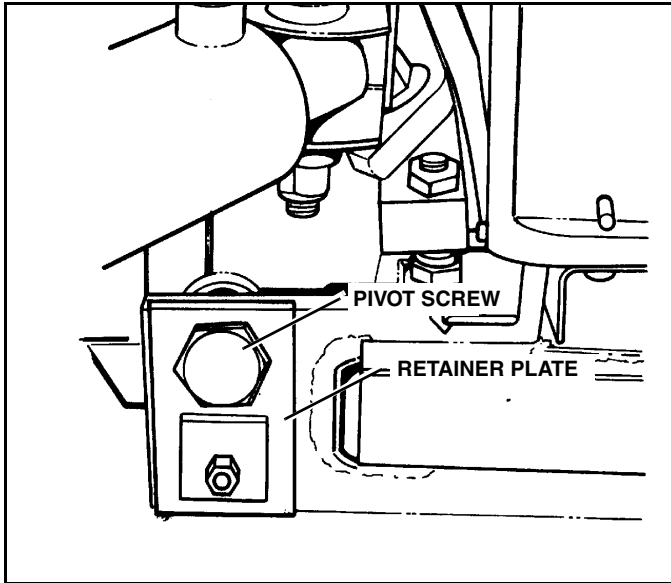

Figure 2-19

1. The hex head of the pivot screw must be seated within the hex opening of the retainer plate.

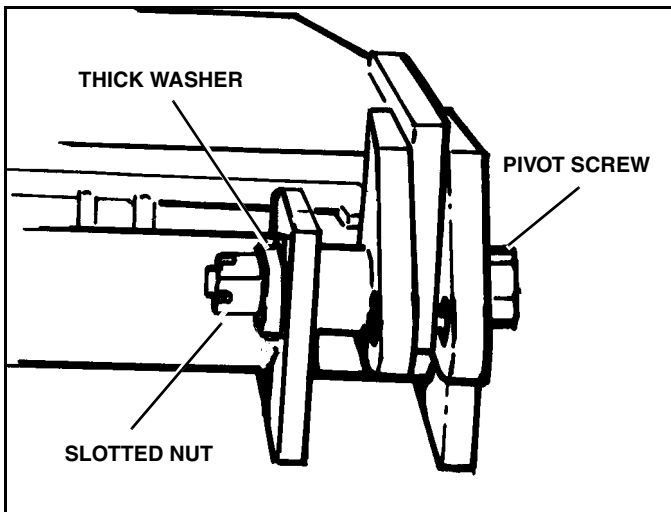

Figure 2-20

2. Install the special 1/4" thick washer on the threaded end of the pivot screw and install the 1" slotted nut finger tight. Then tighten the nut an additional 2/3 to 1 full turn and line up a slot in the nut with the cross hole in the pivot screw. Install a 3/16"x2" cotter pin through the slot in the slotted nut and the cross hole in the pivot screw and spread both cotter pin ends.

Cutting Edge

NOTE: Cutting edge must be replaced when it is worn to the bottom edge of the frame.

1. Raise the plow to the full UP position.
2. Place suitable blocking under A-frame of plow to allow at least 6" of clearance from the blade to the ground.

IMPORTANT: Make sure to position blocking away from cutting edge so that when plow is lowered onto blocking cutting edges do not rest on blocking.

3. Lower plow onto blocking.



WARNING

Keep hands and feet clear of wings and A-frame when setting blocking and lowering blade. Moving or falling assemblies could result in serious injury.

FAILURE TO HEED CAN RESULT IN INJURY OR DEATH.



CAUTION

Cutting edges may be sharp. Always wear gloves and handle cutting edges with care to avoid injury.

4. Remove mounting bolts holding old center cutting edge. Discard old cutting edges, hardware, and backing plate.

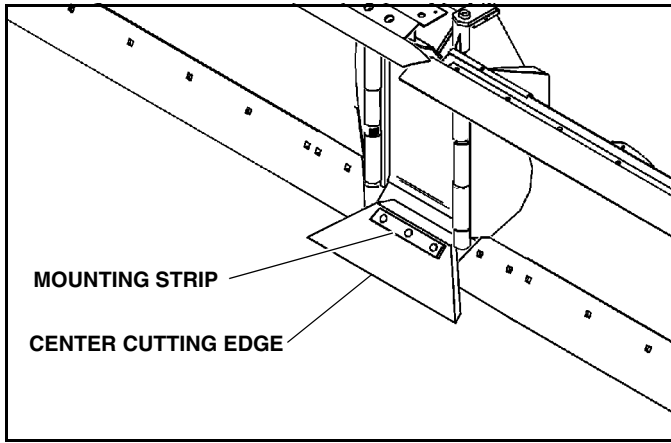

Figure 2-21

NOTE: The blade skin must be retained prior to removing the wing cutting edges. This can be accomplished by using a 6" C-clamp located at the center of the curved portion of the blade skin at the outer end of the wing.

5. Remove the mounting bolts holding the old wing cutting edges to the blade wings. Discard old cutting edges and hardware.

6. Install new wing cutting edges using new hardware.

7. Install new center cutting edge and secure with new mounting strip, new hardware, and new backing plate. Torque the three center cutting edge fasteners to 50 lb-ft.

Trip Spring Adjustment

NOTE: The trip springs are factory installed and adjusted, but adjustment should be checked during plow set-up and installation.

The springs are properly adjusted when the coils begin to separate.

If readjustment is required:

1. Install cylinder lock clamp according to instructions on Page 10.
2. Check to make sure that the spring is installed as illustrated with open end of top loop facing vehicle. (See Figure 2-22).
3. Using a 15/16" socket wrench through the holes in the bottom plate of the main frame, loosen the two (2) 5/8" nuts on the trip spring eyebolts. (See Figure 2-22).
4. After the two lower nuts have been loosened, the two upper nuts can be rotated on the eye bolts to allow the trip springs to be shortened or lengthened.
5. While holding the two upper nuts, re-tighten the two lower nuts and then re-check the spring adjustment.

NOTE: Springs are properly adjusted when two or more coils allow a 0.010" feeler gauge to just pass between the separated coils. (A 3 x 5 post card is approximately the same thickness).



CAUTION

- Do not overtighten springs. If more than 0.015" (1/64") gap appears between coil with plow at rest damage could occur to equipment during plowing.
- Spring must be installed with open end of top loop facing vehicle. Bottom loop position will vary.

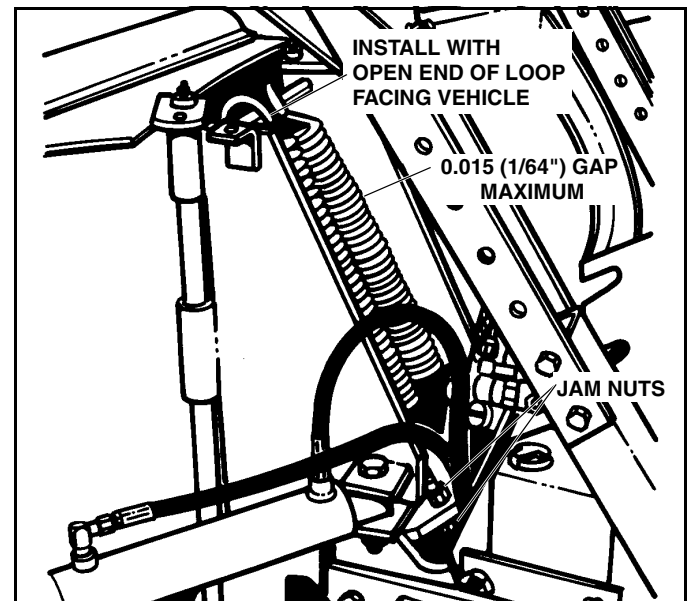









Figure 2-22

NOTES

TORQUE SPECIFICATIONS

SAE Grade and Head Markings	1 or 2 No Marks 	5 5.1 5.2 	8 8.2 
SAE Grade and Nut Markings	2 No Marks 	5  	8  

	Grade 1		Grade 2		Grade 5, 5.1 or 5.2		Grade 8 or 8.2	
	Lubricated ^a	Dry ^b	Lubricated ^a	Dry ^b	Lubricated ^a	Dry ^b	Lubricated ^a	Dry ^b
SIZE	lb-ft	lb-ft	lb-ft	lb-ft	lb-ft	lb-ft	lb-ft	lb-ft
8-32			14*	19*	22*	30*	31*	42*
10-24			21*	27*	32*	43*	45*	60*
1/4	2.8	3.5	4.5	5.5	7	9	10	12.5
5/16	5.5	7	9	11	15	18	21	26
3/8	10	13	16	20	26	33	36	46
7/16	16	20	26	32	41	52	58	75
1/2	25	31	39	50	63	80	90	115
9/16	36	45	56	70	90	115	130	160
5/8	50	62	78	100	125	160	160	225
3/4	87	110	140	175	225	280	310	400
7/8	140	175	140	175	360	450	500	650
1	210	270	210	270	540	675	750	975

DO NOT use these values if a different torque value or tightening procedure is given for a specific application.

Fasteners should be replaced with the same or higher grade. If higher grade fasteners are used, these should only be tightened to the strength of the original.

^a "Lubricated" means coated with a lubricant such as engine oil, or fasteners with phosphate and oil coatings.

^b "Dry" means plain or zinc plated without any lubrication

* Values with asterisk are in lb-in.

HYDRAULIC SCHEMATIC (GRAVITY)

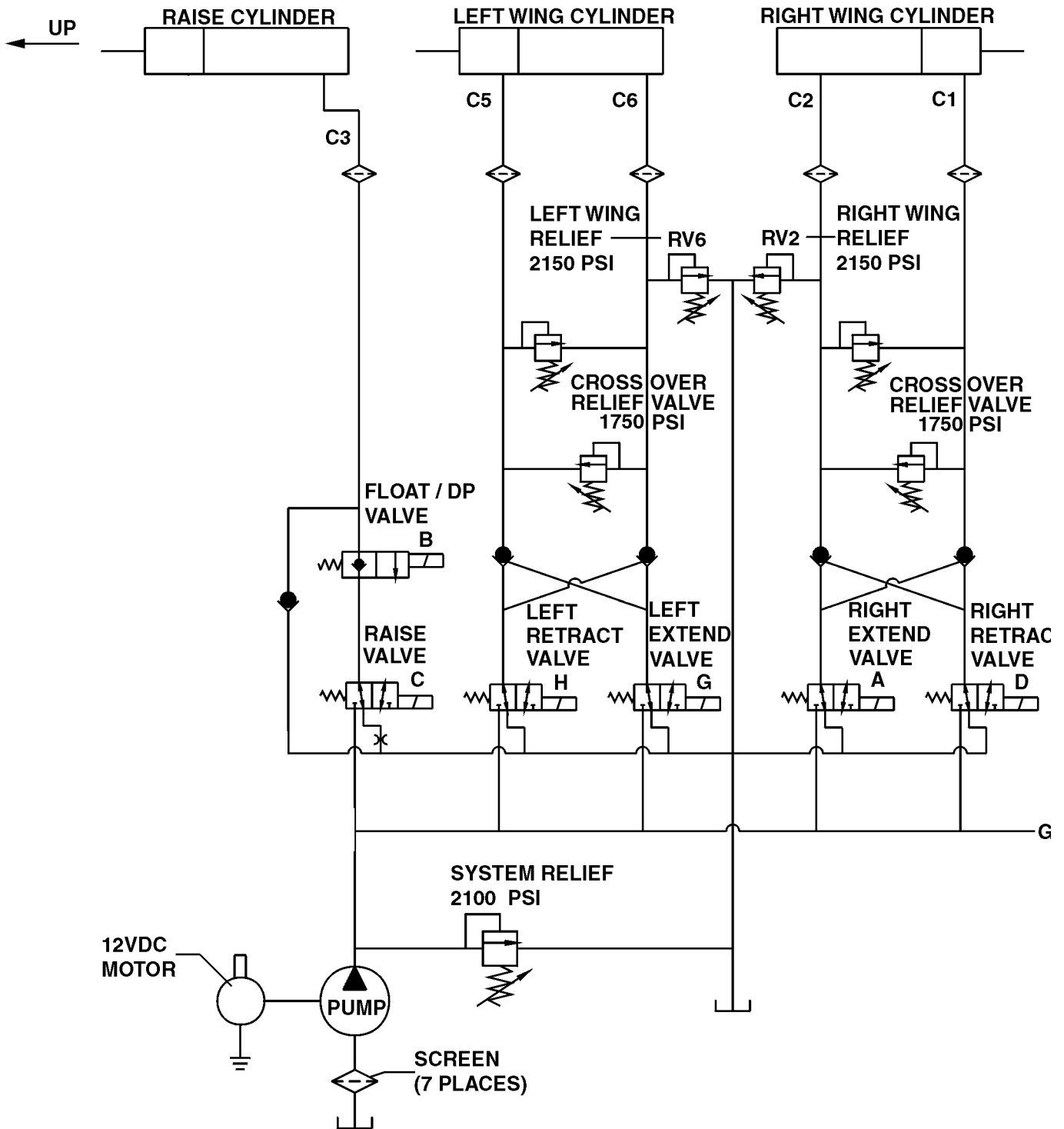

HYDRAULIC SCHEMATIC (DOWN PRESSURE)

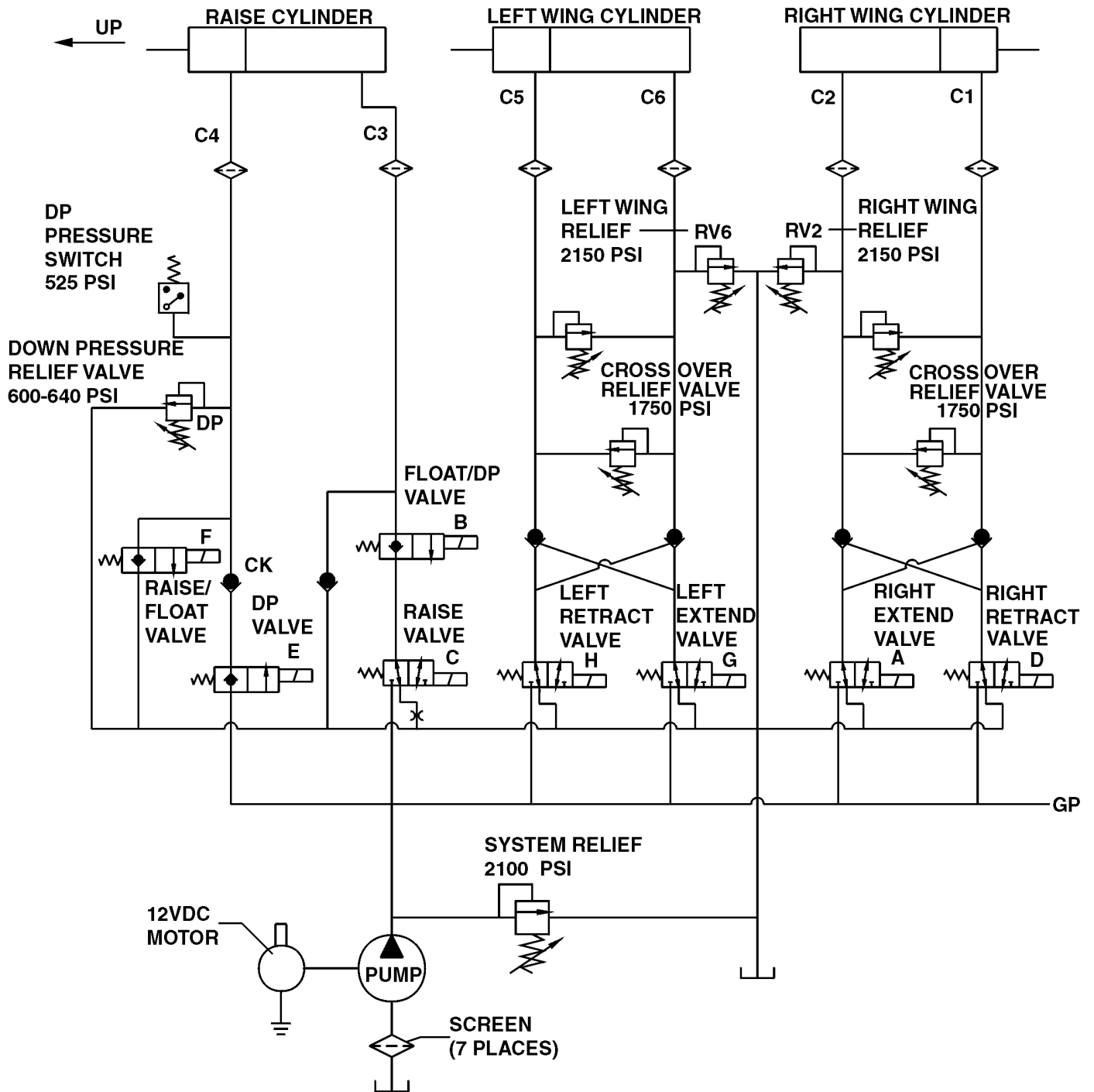

WIRING SCHEMATIC (GRAVITY)

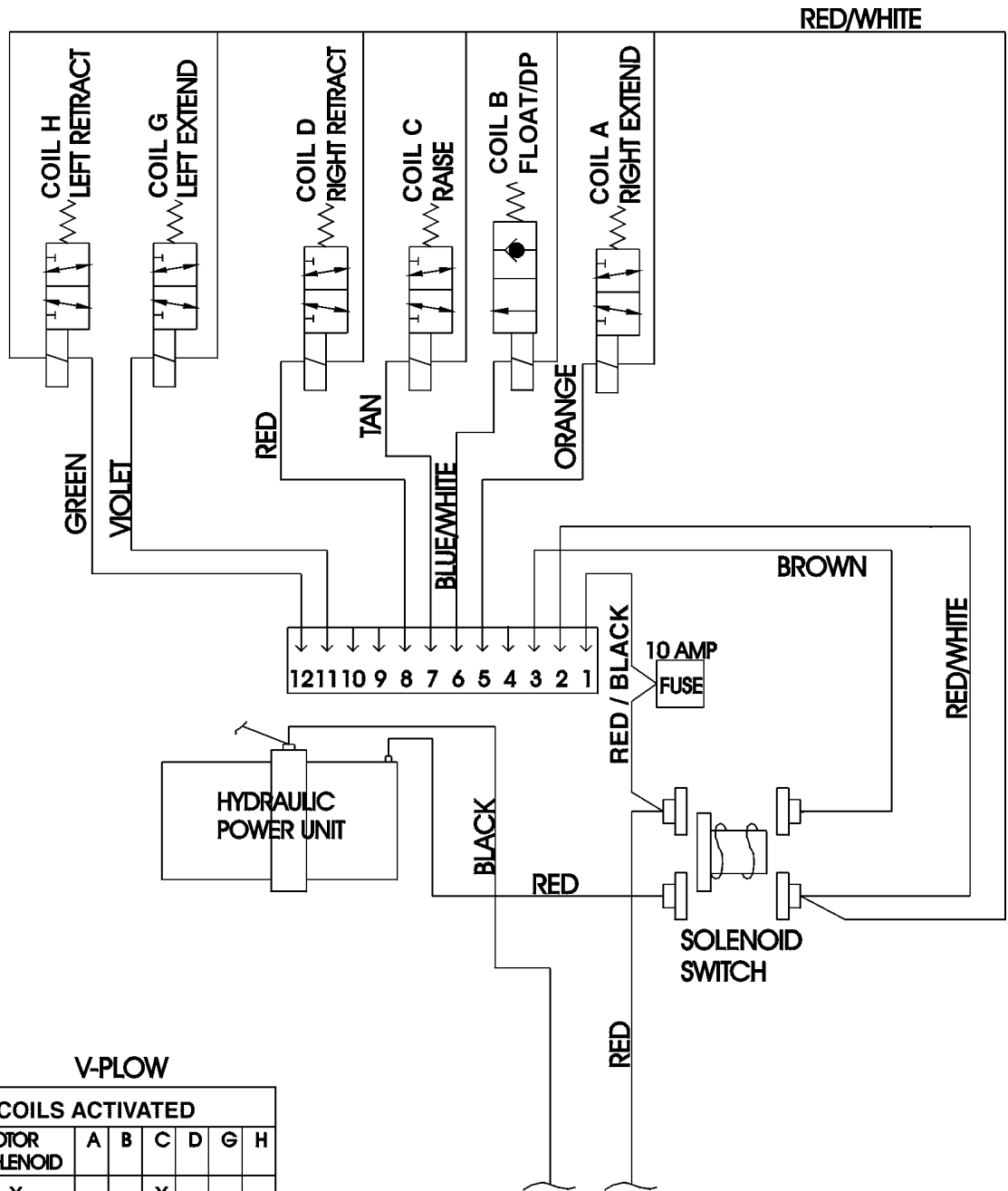

V-PLW

FLOW FUNCTION	COILS ACTIVATED							
	MOTOR SOLENOID	A	B	C	D	G	H	
RAISE	X			X				
DOWN (FLOAT)			X					
LEFT EXTEND	X					X		
LEFT RETRACT	X						X	
RIGHT EXTEND	X	X						
RIGHT RETRACT	X				X			

WIRING SCHEMATIC (DOWN PRESSURE)

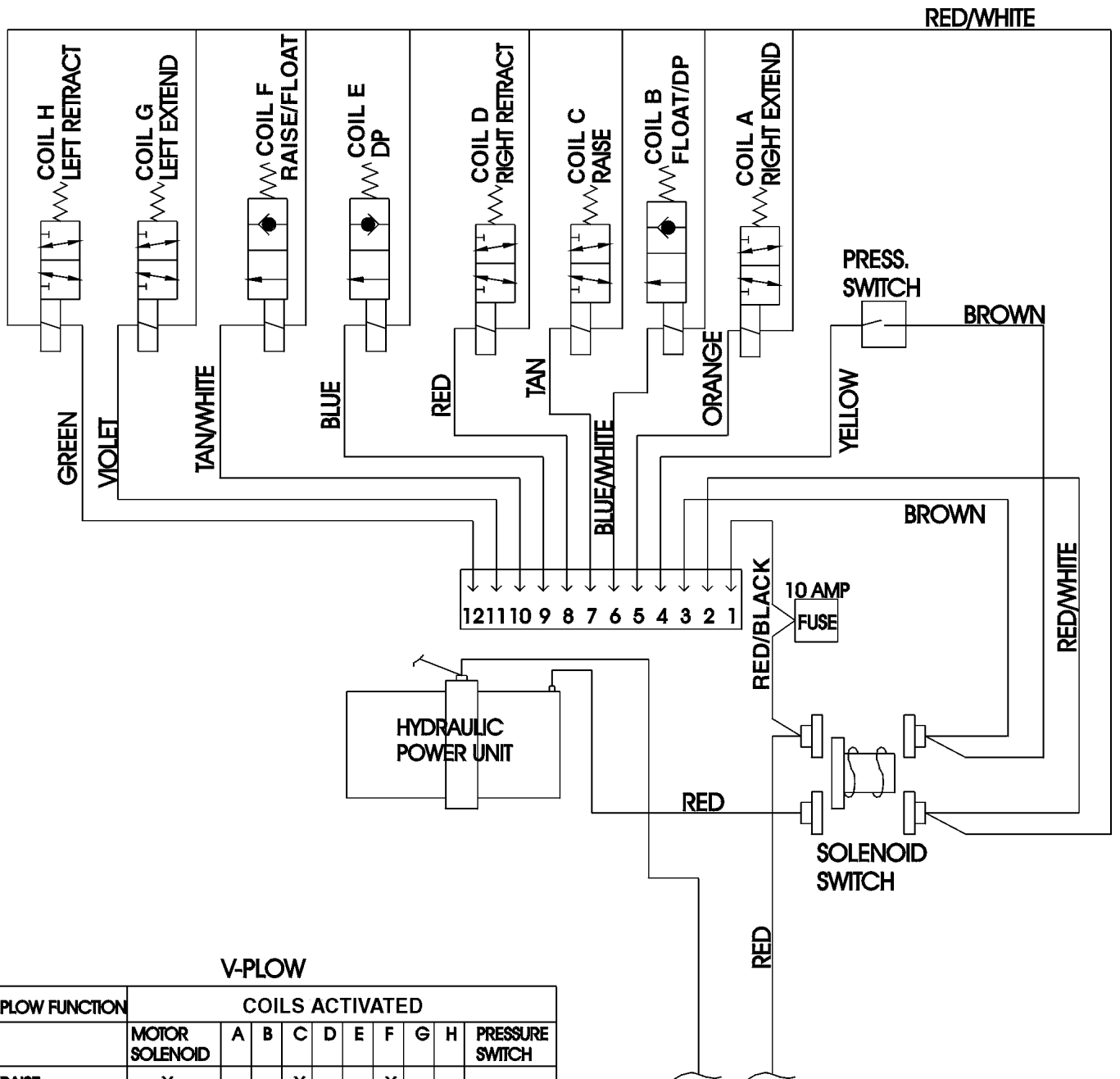

V-PLOW

PLOW FUNCTION	COILS ACTIVATED								PRESSURE SWITCH	
	MOTOR SOLENOID	A	B	C	D	E	F	G		H
RAISE	X			X			X			
DOWN (FLOAT)			X				X			
DOWN PRESSURE	X		X			X				X
LEFT EXTEND	X							X		
LEFT RETRACT	X								X	
RIGHT EXTEND	X	X								
RIGHT RETRACT	X				X					

NOTE: COIL E MUST BE DEACTIVATED FOR WING ANGLE FUNCTIONS

SNO-WAY PLOWS - LIMITED WARRANTY

FIVE YEAR STRUCTURAL LIMITED WARRANTY COVERAGE

The Sno-Way snow plow structural elements are warranted to be free from defects in materials and workmanship for a period of five years from date of delivery from an authorized Sno-Way Dealer. The Sno-Way Warranty Registration card for the product must be properly filled out and mailed to Sno-Way within 30 days of date of purchase to obtain benefits of this section of warranty.

Structural elements are defined for this warranty as: *Blade frames, A-frames, Swing Frames, vehicle sub frames, and structural components (weldments) of Sno-Way snow plows.*

TWO YEAR STANDARD LIMITED WARRANTY COVERAGE

The Sno-Way snow plow non structural components are warranted to be free from defects in workmanship for a period of two years from date of delivery from an authorized Sno-Way Dealer. The Sno-Way Warranty Registration card for the product must be properly filled out and mailed to Sno-Way within 30 days of date of purchase to obtain the benefits of this section of warranty.

Non structural product components are defined for this warranty as: *Blade inserts (polycarbonate or steel) and the SMO1 Hydraulic power system and control module.*

ONE YEAR STANDARD LIMITED WARRANTY ACCESSORIES / SERVICE PARTS / COMPONENTS.

Sno-Way International, Inc. Warrants accessories, service parts and components purchased separately for a period of one year after original purchase to be free from defects in material and workmanship.

DEFINITION OF PRODUCT:

Product as used throughout this warranty means the Sno-Way line of snow plows, straight blades and "V" blades and components thereof.

EXCLUSIONS UNDER THIS WARRANTY PROGRAM:

1. The installation of product must be an approved installation in accordance with the Sno-Way Vehicle Application Guide, Installation Instructions Manual and the Owner's Manual.
2. The "use" of the Sno-Way product must be in conformity with the operating and maintenance instructions as set forth in the Owner's Manual.
3. Damage as a result of accident, misuse and/or negligence is not covered.
4. The polycarbonate moldboard under the two year warranty does not cover: *Puncture, Hazing, Abrasion, Yellowing, Scratching or Chemical Damage.*
5. Normal wear items are excluded (Without limitation): *Paint finish-corrosion/contamination, Bushings and bearings, Plow shoes, Plow cutting edges, Blade markers/pins/clips, Accessory items and non-standard attachments - or any damage caused by the addition of non-standard attachments not sold by Sno-Way.*
6. Specific exclusions relating to items covered under the Two Year Warranty: *Fasteners and damage caused by failure to retighten fasteners, Electric contact corrosion - damage or abrasion of wiring harness, Control key pads/contacts, Any damage resulting from a failure to properly service and maintain the product as prescribed in the Owner's Manual.*
7. General exclusions:
 - (A) Any and all damage from the improper installation of product, misapplication of product, abusive use of vehicle and/or product, failure to properly maintain and service, improper repair, service or alteration of product, and any damage as a result of accident or misuse.
 - (B) Sno-Way will not be liable for any expense not related to defects in materials and workmanship. The attachment of product to or upon a vehicle, including any necessary modification of product or vehicle, is entirely at the purchasers risk and expense, and compliance with applicable motor vehicle rules and regulations is the responsibility of the installer.
 - (C) This Warranty when applicable applies to the "first" purchaser of product installed in accordance with Sno-Way Application Guides, Installation and Owner's Manuals, and to the transfer of the product by the "first" purchaser to another approved vehicle application by an authorized Sno-Way Dealer.
 - (D) The "repair" and/or replacement of any part or component is at the option of Sno-Way.
 - (E) Indirect costs incurred while "product" is being repaired during the warranty period are excluded such as; lost time, equipment rental, transportation charges, and similar incidental charges incurred.

OBTAINING WARRANTY SERVICE

To obtain warranty service, promptly return the product or any defective part at your expense to any authorized Sno-Way Dealer during the warranty period. Replacement or repair of defective or inadequate parts shall be performed without charge for labor or materials by such Dealer at his regular place of business during regular business hours after inspection and determination that the warranty applies.

Purchaser shall prepay all freight charges for returning Product or component to Dealer, Sno-Way or any other location designated by Sno-Way.

Note: The Sno-Way Technical Services help line is designed to service Sno-Way Dealers. Sno-Way Technical and Customer Service will help you locate your nearest Sno-Way Dealer.

Please also use the Sno-Way web site with the Dealer locator: www.snoway.com

DISCLAIMERS:

1. Sno-Way warrants its Products only as set forth in this warranty. Sno-Way makes no other warranties, express or implied, and disclaims all other warranties, including any implied warranty of merchantability or fitness for any particular purpose.
2. Sno-Way's obligations under this warranty are limited to those expressed in this warranty, and Sno-Way shall not be liable to the purchaser or any third party for any direct or indirect, incidental or consequential damage or loss.
3. No person is authorized to modify or add to this warranty in any manner.
4. If any Sno-Way product is improperly installed, altered, misused, damaged or otherwise tampered with, this warranty shall lapse and become null and void.

LEGAL RIGHTS:

Some states do not allow limitations on how long an implied warranty lasts or exclusions or limitations of incidental or consequential damages, so the above limitations or exclusions may not apply fully to you. This warranty gives you specific legal rights, and you may also have other rights which vary from state to state. All "other" provisions and "limitations" not altered by local law shall continue to apply.

ENFORCEMENT/CONSTRUCTION

This Warranty shall be enforced and construed under the laws of the State of Wisconsin.

SNO-WAY® INTERNATIONAL, INC.



Hartford, WI 53027 USA
Website: www.snoway.com
©2006 Sno-Way® International