



# OWNER'S MANUAL

**28 SERIES SNOW PLOW**  
**FOR PLOW SERIAL NUMBERS AFTER**  
**28D101329**

# TABLE OF CONTENTS

	Page
INTRODUCTION .....	2
SAFETY .....	3
THEORY OF OPERATION.....	4
PLOWING OPERATION.....	5
Operating Classes .....	5
Before The Season Begins .....	5
Transporting Vehicle With Blade Attached.....	5
Plowing Like A Pro .....	6
Using The Down Pressure Hydraulic System .....	6
Plowing Roadways .....	6
Clearing Parking Lots.....	6
Mounting Snow Plow To Vehicle .....	7
Installing The Cylinder Lock Clamp.....	9
Removing Snow Plow From Vehicle .....	9
Plow Storage .....	11
TROUBLE SHOOTING GUIDE.....	12
MAINTENANCE .....	17
General .....	17
Periodic Inspection.....	17
Special Fasteners Torques and Requirements .....	17
Hydraulic Cylinders .....	18
Electrical Quick Disconnect Plugs.....	18
Service Intervals .....	18
Fluid Requirements .....	18
Changing Oil and Cleaning Filter Screen .....	18
Disk Shoe Adjustment.....	20
Float Limiter Adjustment .....	22
Pivot Assembly Pivot Screws .....	23
Cutting Edge .....	23
Trip Spring Adjustment .....	24
TORQUE SPECIFICATIONS.....	25
HYDRAULIC SCHEMATIC.....	26
WIRING SCHEMATIC .....	28
WIRING HARNESES	
W1 Wire Harness - Vehicle .....	29
W2 Wire Harness - Control Box "B" .....	29
W3 Wire Harness - Control Box "A" .....	30
W4 Wire Harness - Vehicle End Control .....	30
W5 Wire Harness - Vehicle End .....	31
W6 Wire Harness - Pump End Control.....	31
W7 Wire Harness - Pump End Main .....	32
W8 Wire Harness (No Longer Used) .....	33
W9 Wire Harness - Battery Power .....	33
W10 Wire Harness - Battery Ground.....	33
W11 Wire Harness - Solenoid Switch Power .....	33
W12 Wire Harness - Jackstand Switch Jumper .....	33
W13 Wire Harness - Jackstand Switch Jumper .....	33
W14 Wire Harness - Control Box Jumper (2 Req.).....	33
WARRANTY.....	Inside Back Cover

# INTRODUCTION

This manual was written for the assembly, installation and maintenance of your new Sno-Way Plow. Most importantly, this manual provides an operating plan for safe use. Refer to the Table of Contents for an outline of this manual.

Please keep this manual with your machine at all times as reference material and so it can be passed on to the next owner if the machine is sold.

We require that you read and understand the contents of this manual COMPLETELY, especially the chapter on SAFETY, before attempting any procedure contained in this manual.



The Society of Automotive Engineers has adopted this SAFETY ALERT SYMBOL to pinpoint characteristics that, if NOT carefully followed, can create a safety hazard. When you see this symbol in this manual or on the machine itself, BE ALERT!, your personal safety and the safety of others, is involved.

• Defined in the next column, are the SAFETY ALERT messages and how they will appear in this manual.

 **WARNING**

**FAILURE TO HEED CAN RESULT IN SERIOUS INJURY OR DEATH.**

 **CAUTION**

**Information, that if not carefully followed, can cause minor injury or damage to equipment!**

*NOTE: Additional information concerning the equipment or the procedure that may or may not be contained elsewhere in this manual.*

**BE AWARE! It is illegal to remove, deface or otherwise alter the safety decals mounted on this equipment.**

Record the Power Pack Model Number, Power Pack Serial Number, Controller Serial Number, Blade Model Number, Blade Serial Number and the Pump Serial Number in the space provided below as a handy record for quick reference. The Power Pack Serial Number is located on the A-Frame of the Power Pack. The Blade Serial Numbers are located on one of the middle ribs of each Wing. These plates contain information that your Dealer needs to answer questions or to order replacement parts, if needed, for your unit.

NAME PLATE DATA	
POWER PACK MODEL NUMBER	_____
POWER PACK SERIAL NUMBER <small>(Located on A-Frame of Power Pack)</small>	_____
CONTROLLER SERIAL NUMBER	_____
BLADE MODEL NUMBER	_____
RIGHT WING SERIAL NUMBER <small>(Located on Blade Frame)</small>	_____
LEFT WING SERIAL NUMBER <small>(Located on Blade Frame)</small>	_____
PUMP SERIAL NUMBER	_____
(FILL IN)	

DEALER	
NAME	_____
ADDRESS	_____
CITY	_____ STATE _____ ZIP _____
PHONE ( ) -	_____
(FILL IN)	

ORIGINAL PURCHASER	
NAME	_____
ADDRESS	_____
CITY	_____ STATE _____ ZIP _____
PHONE ( ) -	_____
(FILL IN)	

We reserve the right to make changes or improve the design or construction of any part(s) without incurring the obligation to install such parts or make any changes on any unit previously delivered.

Sno-Way snow plow Service Parts Manuals are available for purchase from your authorized Sno-Way dealer. Sno-Way snow plow Service Parts Manuals may also be ordered from the address on the back of this manual by requesting part number 97100465.



## SAFETY



**BEFORE ATTEMPTING ANY PROCEDURE IN THIS BOOK, READ AND UNDERSTAND ALL THE SAFETY INFORMATION CONTAINED IN THIS SECTION. IN ADDITION, ENSURE ALL INDIVIDUALS WORKING WITH YOU ARE ALSO FAMILIAR WITH THESE SAFETY PRECAUTIONS.**

**For your safety Warning and Information Decals have been placed on this product to remind the operator to take safety precautions. It is important that these decals are in place and are legible before operation begins. New decals can be obtained from Sno-Way or your local dealer.**

**REMEMBER** The careful operator is the best operator. Most accidents are caused by human error. Certain precautions must be observed to prevent the possibility of injury to operator or bystanders and/or damage to equipment.

**NEVER** operate Plow when under the influence of alcohol, drugs or other medications that could hamper your judgement and reactions. An accident may result in serious injury or death to other persons or yourself.

**ALWAYS** operate vehicle in a well-ventilated area. The carbon monoxide in exhaust gas is highly toxic and can cause serious injury or death.

**NEVER** allow hands, hair or clothing to get near any moving parts such as fan blades, belts and pulleys. Never wear neckties or loose clothing when working on the vehicle.

**NEVER** wear wrist watches, rings or other jewelry when working on the vehicle or individual equipment. These things can catch on moving parts or cause an electrical short circuit that could result in serious personal injury.

**ALWAYS** wear safety goggles when working on the vehicle to protect your eyes from battery acid, gasoline, and dust or dirt from flying off of moving engine parts.

**ALWAYS** be aware of and avoid contact with hot surfaces such as engine, radiator, and hoses.

**ALWAYS** wear safety glasses with side shields when striking metal against metal! In addition, it is recommended that a softer (non-chipable) metal material be used to cushion the blow. Failure to heed could result in serious injury to the eye(s) or other parts of the body.

**NEVER** allow children or unauthorized person to operate this unit.

**NEVER** exceed 45 m.p.h. when snow plow is attached to vehicle. Braking distances may be reduced and handling characteristics may be impaired at speeds above 45 m.p.h.

**ALWAYS** lock the vehicle when unattended to prevent unauthorized operation of the plow.

**ALWAYS** check the job site for terrain hazards, obstructions and people.

**NEVER** exceed 10 m.p.h. when plowing. Excessive speed may cause serious injury and damage of equipment and property if an unseen obstacle is encountered while plowing.

**ALWAYS** position blade so it does not block path of headlamps beam. Do not change blade positions while traveling. An incorrect plow position blocking headlamp beam may result in an accident.

**ALWAYS** check surrounding area for hazardous obstacles before operating this unit.

**ALWAYS** inspect the unit periodically for defects. Parts that are broken, missing or plainly worn must be replaced immediately. The unit, or any part of it should not be altered without prior written approval of the manufacturer.

**ALWAYS** insert the cylinder lock when plow is not in use. If the cylinder lock is not installed, the plow blade could inadvertently drop and cause serious injury.

**ALWAYS** shut off the vehicle engine, place the transmission in Neutral or Park, turn the ignition switch to the "OFF" position and firmly apply the parking brake of the vehicle before attaching or detaching the blade from the vehicle or when making adjustments to the blade.

**ALWAYS** inspect lift system bolts and pins whenever attaching or detaching the plow, and before traveling. Worn or damaged components could result in the plow dropping to the pavement while driving, causing an accident.

**ALWAYS** keep hands and feet clear of blade and A-Frame when attaching or detaching plow.

**NEVER** place fingers in A-frame or mount lug holes to check alignment when attaching snow plow. Sudden motion of the plow could severely injure a finger.

**NEVER** stand between the vehicle and blade or directly in front of blade when it is being raised, lowered or angled. Clearance between vehicle and blade decreases as blade is operated and serious injury or death can result from blade striking a body or dropping on hands or feet.

**NEVER** work on the vehicle without having a fully serviced fire extinguisher available. A 5 lb or larger CO<sup>2</sup> or dry chemical unit specified for gasoline, chemical or electrical fires, is recommended.

**NEVER** smoke while working on the vehicle. Gasoline and battery acid vapors are extremely flammable and explosive.

**NEVER** use your hands to search for hydraulic fluid leaks; escaping fluid under pressure can be invisible and can penetrate the skin and cause a serious injury! If any fluid is injected into the skin, see a doctor at once! Injected fluid **MUST BE** surgically removed by a doctor familiar with this type of injury or gangrene may result.

**REMEMBER** it is the owner's responsibility for communicating information on the safe use and proper maintenance of this machine.

# THEORY OF OPERATION

## Hydraulic Power Unit

The Hydraulic Power Unit consists of a 12VDC Motor, a Hydraulic Pump rated at 1.9 GPM @ 1650 PSI, and a Valve Body containing Seven (7) Electric Solenoids, three (3) Pressure Switches and five (5) Pressure Relief Valves. The fluid supply line for the pump is submerged in a 2.0 quart capacity Reservoir and is equipped with a fine mesh Intake Filter.

The Valve Body directs hydraulic fluid to operate five hydraulic circuits, raise, lower, angle left side, angle right side, and down pressure. The angle and lift circuits receive fluid under pressure. Normally the lower circuit is un-powered, however, a slight pressure is generated in this circuit as fluid returns to the reservoir.

This unit is equipped with a DOWN PRESSURE system that allows the operator to selectively switch the system to provide additional Hydraulic force to the lowering of the plow.

The angle left side or angle right side hydraulic circuits receive priority over the raise hydraulic circuit. If the raise circuit is operated while angling the blade wings, the blade will angle but will not raise until the Angle Switches are released. Angling the blade wings while lowering the blade will still allow the wings to angle and to lower because hydraulic pressure is not needed to lower the blade.

**IMPORTANT: The electric coils, which operate the solenoid valves, require a minimum of 9-1/2 volts DC for proper operation. Lower Voltage will cause erratic operation, or failure to operate.**

## Raise Mode Of Operation

Operating the Raise Switch energizes the 12VDC Motor and de-energizes the Raise/Lower Solenoid. Hydraulic fluid under pressure is then directed through a one way Check Valve to the raise side of the lift cylinder.

Releasing the Raise switch de-energizes the 12 VDC motor. The raise circuit is protected by a pressure relief valve set to relieve system pressure at approximately 2100 PSI. Typically, pressure is relieved when the hydraulic lift cylinder reaches the full UP position.

## Lower Mode Of Operation

Operating the Lower Switch energizes the Raise/Lower Solenoid (if down pressure system is off), lowers the blade and establishes a Float Circuit. The Float Circuit allows fluid to enter and exit the Raise Cylinder allowing the blade to follow the contours of the ground.

**IMPORTANT: The lower valve is closed by spring pressure. If it does not close completely against the valve seat, the plow can slowly lower after the raise switch is released. If this occurs, cycle the plow through a raise and lower cycle a few times to flush out anything that may be between the valve and seat, this also allows the valve and valve seat to mate and seal.**

## Wing Angling Mode Of Operation

Each Wing can be angled forward or rearward independently by operating the Wing Angle Switch for either the Right or Left Wing. Operating the Wing Angle Switch energizes the 12 VDC Motor and either the Extend or Retract Solenoid for the Wing, which directs hydraulic fluid, under pressure, to either the base end (Extend) or rod end (Retract) of the Wing Cylinder, which then moves the Wing forward or rearward. Each Wing Angling Circuit is protected by a crossover Relief Valve set at 1500 psi as well as the System Relief Valve set at 2100 psi and a Wing Cylinder Relief Valve set at 2150 psi.

## Down Pressure System

Current to the Down Pressure Rocker Switch is supplied through the lower position of the Raise/Lower Switch.

Positioning the Down Pressure Rocker Switch to ON supplies power to the Indicator Light, energizes the Four-way Solenoid Valve, supplies power to the Pressure Switch and de-energizes the Raise/lower Solenoid Valve.

The Four-way Solenoid Valve, when energized, directs fluid flow to the down side of the Lift Cylinder. When de-energized, hydraulic pressure is equalized in the Lift Cylinder allowing the Plow to float and follow the contour of the ground.

The Pressure Switch senses hydraulic pressure in the down side of the Lift Cylinder. When pressure falls current is supplied to the DC Motor and hydraulic pressure is supplied to the down side of the Lift Cylinder. When pressure increases the Pressure Switch opens and stops current flow to the DC Motor.

## DC Motor Start Solenoid

Current to energize the DC Motor is supplied through the DC Motor Start Solenoid. Current to activate the Start Solenoid comes from the Raise/lower Switch, left and right Wing Angle Switches, or the down pressure system Pressure Switch.

## Controls And Indicators

### Raise/Lower Switch:

Used to raise or lower the blade.

### Left Wing Angle Switch:

Used to angle the left wing forward and rearward.

### Right Wing Angle Switch:

Used to angle the right wing forward and rearward.

### Down Pressure Rocker Switch:

Used to activate the down pressure system. Must be in off position for float system to operate.

### Down Pressure On Indicator Light:

Comes on when down pressure switch is turned on. The light indicates switch position only, it does not indicate proper system operation.

# PLOWING OPERATION

## Operating Classes

### 28 Series

The 28 Series Sno-Way Plow is specifically designed for heavy duty Snow Plowing with full size 1/2, 3/4 and 1 ton 4x4's.

*NOTE: The loaded vehicle, including any ballast weight and optional equipment, must not exceed the Gross Vehicle Weight (GVW) or front or rear Gross Axle Weight (GAW) ratings specified on the Safety Compliance Certification Label located on the driver's side door opening.*

*NOTE: All vehicles that are equipped with Sno-Way Snow Plows should be equipped with all vehicle manufacturer's recommended options for snow plowing.*

For additional information, refer to your dealer and the Sno-Way Application Guide for proper vehicle applications.

## Before The Season Begins

1. Inspect vehicle safety equipment for proper operation; brakes, headlights, plowing lights, windshield wipers, flashers, etc.

2. Inspect the plow, plow frame and all attaching hardware for wear and corrosion. Replace worn or damaged parts and clean and repaint exposed metal parts with a high quality, corrosion resistant enamel.

3. Inspect all fasteners to insure that they are properly tightened. If any fasteners are loose, re-tighten to the proper torque (refer to the Torque Specification Chart in this manual) and carefully inspect the adjacent area for damage or wear as well as carefully inspecting all adjacent fasteners for proper torque.

4. Apply a small amount of light oil to the Hitch Pins and pivots, to Pivot Pins between the A-Frame and Center Blade Assembly, between Lift and Swing Cylinder Pivot Pins and the Lift Linkage Pivots.

5. Check the Wing Pivots for free movement of the wings on the Pivot Shafts. Lubricate the Wing Pivot Shafts with a good quality light weight HP Lithium based grease.

6. For extremely cold weather plowing, continuous sub Zero operation, an alternative is to remove the grease fittings and fill the grease cavity with SAE 140 Gear Oil, and then replace the grease fitting.

7. Check the reservoir oil level (see maintenance instructions) and repair any oil leaks and worn hoses.

8. Install auxiliary and flashing lights (if not equipped). Ensure auxiliary lights are aimed properly (with plow in full UP position).

9. If ballast is required position ballast behind rear wheels for optimum performance.

## Transporting Vehicle With Blade Attached



### WARNING

**Ensure ignition switch is OFF before installing or removing the cylinder lock clamp. Equipment failure or inadvertent operation of the control switches could allow the plow blade to fall, resulting in serious injury.**

**FAILURE TO HEED CAN RESULT IN SERIOUS INJURY OR DEATH.**

1. Always install the cylinder lock clamp when the plow blade is raised and the operator is not engaged in plowing operations.

*NOTE: If Cylinder Lock Clamp is not installed during transport equipment failure or inadvertent operation of the control switches while driving could allow the plow blade to fall.*

2. Always transport the plow with the wings fully folded to the rear to keep the transport width to a minimum.



### CAUTION

**Remove the plow when driving extended distances at temperatures above 40° F, the plow blocks enough airflow to the vehicle's radiator to cause it to overheat at temperatures above 40° F.**

3. DO Not exceed 45 m.p.h. when driving with the Snow Plow attached. Braking distance is increased and handling is impaired dramatically at speeds above 45 m.p.h.

4. Reduce speed when crossing railroad tracks or when road conditions deteriorate.

5. Never change blade angle or height while driving.

6. Position the blade out of the beam path of the headlights before driving.

7. Inspect plow and plow attaching hardware for wear or damage before transporting and beginning plow operations.

## Plowing Like A Pro



### WARNING

• **Never exceed 10 m.p.h. when plowing! Serious personal injury can result, as well as damage to equipment and property, if an unseen obstruction is encountered while plowing.**

• **Never plow with your head protruding from the vehicle side window. Serious head or neck injuries can result from sudden stops or coming into contact with tree branches, signs or other stationary objects.**

**FAILURE TO HEED CAN RESULT IN SERIOUS INJURY OR DEATH.**



### WARNING

**Wear your seat belt! Contact with a hidden obstruction can cause serious personal injury from bodily contact within the vehicle cab or whiplash from sudden stops.**

**FAILURE TO HEED CAN RESULT IN SERIOUS INJURY OR DEATH.**

1. Become familiar with the area to be plowed and mark potential hazards before the snow falls. Many immovable objects cannot be seen when covered with snow. Developing a plan early can save valuable time and equipment damage. Allow sufficient room to pile snow, out of the traffic area, with enough space for snow when the next storm comes.

2. Plow with the storm. The “Pros” are out early removing only several inches of snow at a time. Allowing snow to accumulate to unmanageable levels can cause difficult removal problems and can be costly in terms of “wear and tear” on equipment. The plow is not a “Ram or Bulldozer”, if used properly, it will give you many years of safe and reliable service.

3. Research municipal ordinances for restrictions on the disposal of snow. Many municipalities do not allow snow to be placed in roads or throughway.

## Using The Down Pressure Hydraulic System

The Down pressure system was designed for removing hard packed snow from hard surfaces that have had traffic on them prior to being plowed.

The system should be turned OFF when plowing surfaces such as gravel, dirt, sand, etc., to prevent cutting into the surface being plowed.

Activating the system applies Down Pressure to the down side of the hydraulic lift cylinder. This down pressure will force the blade through the hard-packed snow and down to the pavement. If down pressure decreases, (results if a valley or low spot is encountered by the blade), more down pressure is applied to lower side of the lift cylinder and the blade will follow the contour of the valley. When a hill or a high spot is encountered by the blade, the down pressure will be relieved on the down side of the lift cylinder, this will allow the blade to follow the contour of the hill without lifting the front of the vehicle off the ground.

## Plowing Roadways

A roadway covered with unpacked snow that is not over 4-6" deep can be plowed by angling the Plow Wings to move the snow all to one side.

If the roadway is covered with deep and/or hard packed snow, position the Plow Wings in a "V"-position to move snow equally to each side to open the first path through the roadway. The roadway can then be widened by making successive passes on each side of the first path, with the wings angled to move snow to one side.

## Clearing Parking Lots

1. Plow a single path, with the Plow in a "V" position, through the lot at right angle to the side of the lot where you want to “stack” the snow.

2. With the plow angled to one side, widen the path until the snow piled to the side of the path is large enough for a full “scoop” to be moved to the edge of the lot for stacking.

3. With the blade in “scoop” position, push the snow plowed to the edge of the path to the edge of the lot and “stack” it in a pile.

4. If the snow plowed to the edge of the path is too large to push the entire pile to the edge of the lot, fill the blade, in “scoop” position, and then push the pile over into the cleared path and then to the edge of the lot. Then return, and with the blade in “scoop” position, push the remaining row of plowed snow to the edge of the lot.

5. When “stacking” snow, pushing the plow filled with snow into the existing pile will usually cause the plow to raise somewhat as it goes into the pile allowing the “stack” to be built higher. If necessary, raise the plow as the snow is pushed in the stack to help build the pile higher.

6. If the snow in the lot is deep and/or hard packed, plow all the paths through the lot with the blades in the "V" position. This will put less sideload on the vehicle and will make plowing the paths easier.

## Mounting Snow Plow To Vehicle



### WARNING

#### VEHICLES EQUIPPED WITH AIR BAGS!

Certain Vehicles equipped with Air Bags cannot be equipped with Snow Plows because of the possibility of the Air Bag being deployed if the Snow Plow hits an obstruction. Before attempting to install a Snow Plow on a vehicle equipped with Air Bags, consult with the vehicle manufacturer to be sure that Snow Plow operation will not result in inadvertent deployment of the vehicle air bag.

#### FAILURE TO HEED CAN RESULT IN SERIOUS INJURY OR DEATH.

1. Move the vehicle to the Snow Plow and position it so that the mounting points at the rear of the A-Frame are within 3-4 inches of the lower mounting points of the Subframe on the vehicle (It is much easier to move the vehicle instead of the plow).



### WARNING

Be sure all plow functions are OFF on ALL plow controls in the vehicle cab and the Raise/Lower Rocker Switch on the Pump Cover is in the OFF position before making ANY electrical connections.

#### FAILURE TO HEED CAN RESULT IN SERIOUS INJURY OR DEATH.



### WARNING

- Ensure Engine is OFF and set parking brake before mounting Snow Plow to vehicle. Vehicle movement, equipment failure, or inadvertent operation of the control switches during installation could result in serious injury.

- NEVER place fingers in A-Frame or mount lug holes to check alignment. Sudden motion of the plow could severely injure a finger.

#### FAILURE TO HEED CAN RESULT IN SERIOUS INJURY OR DEATH.

2. Remove the protective Plastic Covers from the Snow Plow Wiring Harnesses and store them inside the vehicle for installation when the plow is removed.

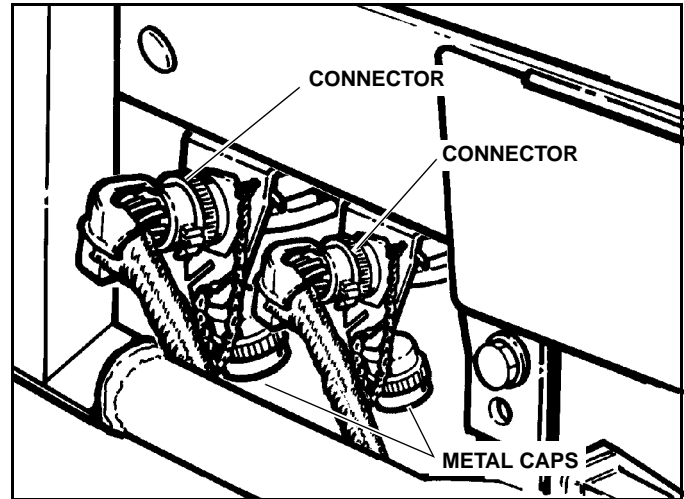

Figure 1-1

3. Remove the Metal Caps from the vehicle end of the Wiring Harnesses by rotating them counterclockwise and store them as shown in Figure 1-1, if Metal Caps are chained to the Harness Plug Bracket. If Metal Caps are not chained to the brackets store the Metal Caps in the vehicle for future use.



### CAUTION

NEVER use pliers or any other tool to force the Connector halves together.

4. Align the two Harness Connector halves, push the plow end Connector onto the vehicle Connector and rotate clockwise to lock. Connect all electrical connections between the Snow Plow and the vehicle, except for Light Harness, if the Snow Plow is equipped with lights.

5. Turn vehicle ignition switch to the run position.

6. Place the Up/down Switch on the Plow Controller, in the cab of the vehicle, in the down position and also activate the Down Pressure Switch on the Plow Controller.



## WARNING

When using the raise/lower Rocker Switch on the Pump Cover to raise or lower the Plow A-Frame be especially careful of the movement of the light bar, if equipped, which occurs during raising and lowering of the A-Frame on the Jackstand.

**FAILURE TO HEED CAN RESULT IN SERIOUS INJURY OR DEATH.**

7. Raise the rear of the A-Frame (using the Rocker Switch on the pump cover) to ensure that the A-Frame is higher than the Subframe mounting points. The plow can then be manually moved into position for connecting the lower Hitch Pins. Move the plow manually by grasping one end of the blade and moving one side and then the other side. Again, if the plow is more than 3-4 inches from proper alignment, move the vehicle - it's easier. But remember to disconnect the electrical connections **BEFORE** backing away from the plow to avoid stretching and damaging the electrical Wiring Harness. (See Figure 1-2)



## CAUTION

**NEVER** move vehicle while plow is connected electrically.

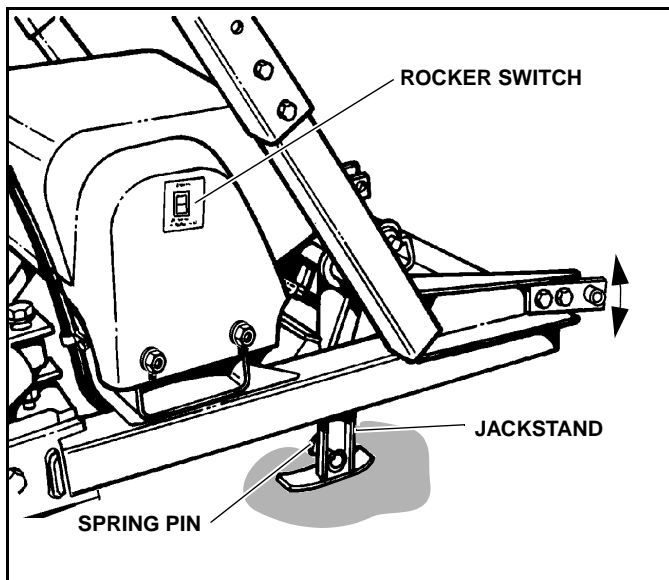

Figure 1-2

8. Lower the A-Frame into alignment with the lower Hitch Pin mounting holes of the vehicle Subframe and install the two lower Hitch Pins. Secure with Lynch Pins. (See Figure 1-4)

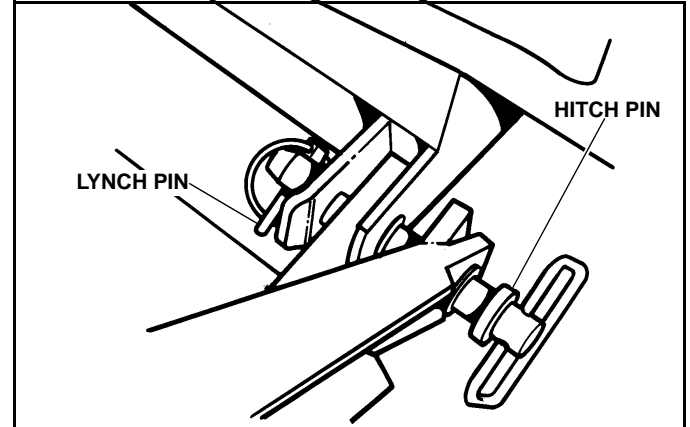

Figure 1-3

*NOTE: If the plow and vehicle are not level with each other, install one lower Hitch Pin and then, using the Rocker Switch on the pump cover, (See Figure 1-3) adjust the A-Frame height to allow installation of the second lower Hitch Pin.*

9. After the lower Hitch Pins and Lynch Pins have been installed, place the Rocker Switch in the lower position to allow the Jackstand to be raised off the ground. Then rotate the Jackstand forward and upward and latch it in the transport storage position with the Spring Pin. (See Figure 1-2)

**IMPORTANT:** The end of the Spring Pin fits into a short tube on the side of the Bellcrank assembly. If the Pin is not retained in this tube, the Jackstand may become loose and fall down during plowing or transport.

10. Raise the Lift Link and Light Bar manually to align the upper Hitch Pin mounting lugs and slide the upper Hitch Pin into place. Install the Lynch Pin to retain the Hitch Pin. (See Figure 1-4)

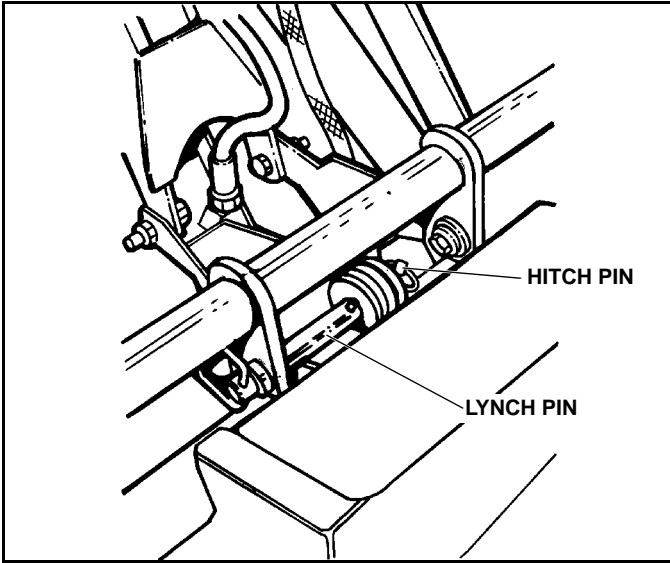

Figure 1-4

11. Connect the Snow Plow Light Harness to the vehicle light harness.

12. Move the Rocker Switch on the Pump Cover to the "lower" position to allow normal Snow Plow operation.

## Installing The Cylinder Lock Clamp



### WARNING

- Always install the Cylinder Lock Clamp when the plow blade is raised and the operator is not engaged in plowing operations. Equipment failure or inadvertent operation of the control switches while driving could allow the plow blade to fall, resulting in serious injury.

- Ensure Engine is OFF and set parking brake before installing the Cylinder Lock Clamp. Vehicle movement, equipment failure, or inadvertent operation of the control switches during installation could allow the plow blade to fall, resulting in serious injury.

#### FAILURE TO HEED CAN RESULT IN SERIOUS INJURY OR DEATH.

1. Raise the plow to the full UP position and fully extend Left Wing.

2. Turn ignition switch OFF and apply the emergency brake.

3. Remove the Pins from the Cylinder Lock Clamp and spread it apart.

4. Position the Cylinder Lock Clamp around the exposed (chrome) portion of the Lift Cylinder and install the Pins. Install the Hairpin Cotter Into the Pins. (See Figure 1-5)

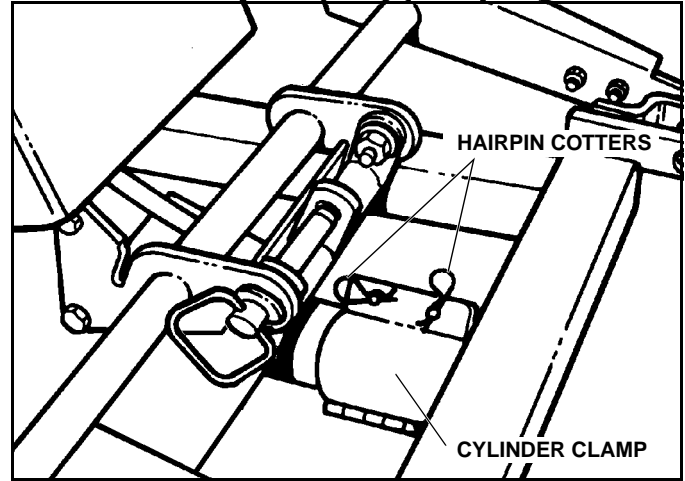

Figure 1-5

## Removing Snow Plow From Vehicle

Choose a location for plow storage which will allow the plow to be removed from the vehicle and not moved after removal. Also, choose a location which will not allow the stand to sink into the ground during storage.

1. Drive vehicle to the desired Snow Plow storage area. It is recommended that the plow be stored in a dry protected area.

*NOTE: Plow should be thoroughly cleaned of all grime and road salt before it is put into storage*

2. Retract wings to a "V" position and lower the plow to the ground.

3. Put vehicle in park and turn off engine.



### WARNING

- Ensure engine is OFF and parking brake is set before removing Snow Plow from vehicle. Vehicle movement, equipment failure, or inadvertent operation of the control switches during removal could result in serious injury.

- Ensure all personnel are clear of the area surrounding the blade storage location before angling or lowering the blade to prevent serious injury.

#### FAILURE TO HEED CAN RESULT IN SERIOUS INJURY OR DEATH.

4. Turn vehicle ignition switch to run position only.

5. With the Snow Plow attached to the vehicle and lowered to the ground, place the raise/lower Rocker Switch on the Pump Cover in the lower position. Place the Up/down Switch on the Plow Controller in the cab of the vehicle in the down position and activate the Down Pressure Switch on the Plow Controller. (See Figure 1-6)

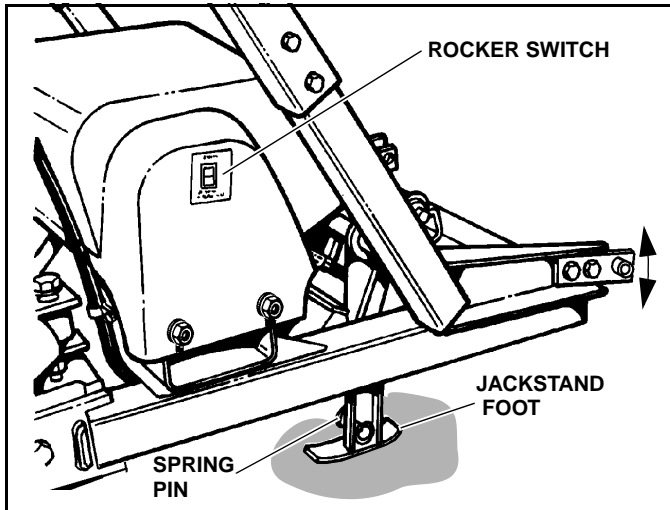

Figure 1-6



**WARNING**

When using the raise/lower Rocker Switch on the Pump Cover to raise or lower the plow A-Frame, be especially careful of movement of the Light Bar which occurs during raising and lowering of the A-Frame on the Jackstand.

**FAILURE TO HEED CAN RESULT IN SERIOUS INJURY OR DEATH.**

6. Next, move the Rocker Switch on the Pump Cover to the off position (center position of toggle).

7. Pull the Spring Pin on the Jackstand to release the Jackstand from the transport position and allow the foot to rotate down to a vertical position. (See Figure 1-6)

**IMPORTANT: IF THE SNOW PLOW IS EQUIPPED WITH LIGHTS, DISCONNECT THE LIGHT WIRING HARNESS AT THIS TIME.**

8. Pull the Lynch Pin from the upper (center) Hitch Pin and slide Hitch Pin out to disconnect the Lift Arm and Light Bar from the upper (center) hitch point of the Sub-frame. (See Figure 1-7)

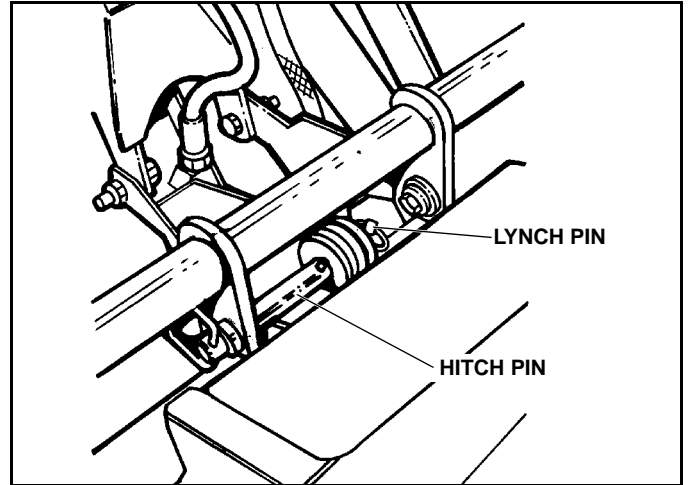

Figure 1-7



**WARNING**

Keep hands and feet clear of Wings and A-Frame when detaching plow. Moving or falling assemblies could result in serious injury.

**FAILURE TO HEED CAN RESULT IN SERIOUS INJURY OR DEATH.**

9. Using the Rocker Switch on the Pump Cover, place the Jackstand foot firmly on the ground by using the raise function of the Rocker Switch.

10. Remove the Lynch Pins from the two lower Hitch Pins. Using the Rocker Switch will allow the rear of the A-Frame to be raised or lowered to take pressure off the two lower Hitch Pins to allow easier removal of the Hitch Pins. (See Figure 1-8)

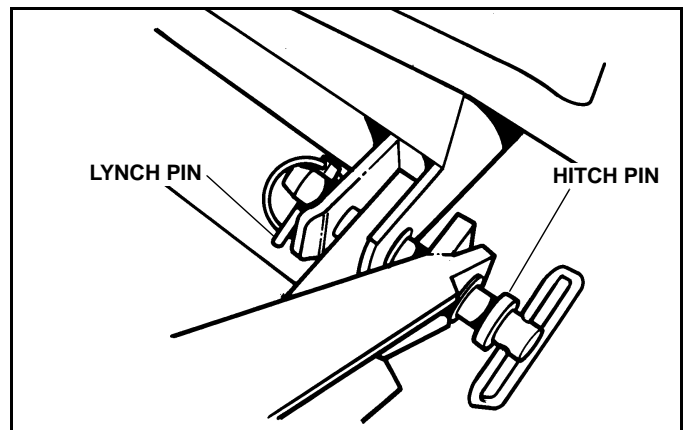

Figure 1-8

11. After the lower Hitch Pins are removed, raise the rear of the A-frame (using the raise function of the Rocker Switch) to allow the A-Frame to clear the lower mounting points of the Subframe.

12. After the plow is positioned satisfactorily for storage, disconnect the electrical connections between the Snow Plow and vehicle.

13. Rotate the outer collars of the electrical quick disconnect plugs counterclockwise to unlock, then pull Snow Plow end of plugs out of connectors.

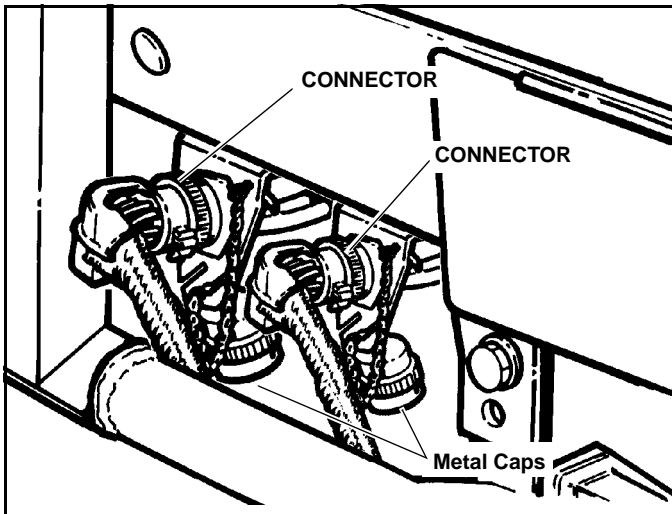

Figure 1-9

*NOTE: Place protective Metal Caps on the vehicle half of the quick disconnects and place the plastic storage Covers (normally kept in the vehicle) on the Snow Plow half of the wiring harness connectors. Tuck the Snow Plow end of the plugs in an area of the Snow Plow where they are not exposed to potential damage such as crushing or corrosion.*



## CAUTION

**Never use pliers or any other tool to separate the wiring harness connector halves.**

14. After all mechanical and electrical connections have been disconnected, back the vehicle away from the Snow Plow.

## Plow Storage

1. If the plow will not be stored on a firm surface (i.e. concrete or asphalt), place a board or piece of plywood, etc. under the Jackstand to prevent the Jackstand foot from sinking into the ground.

2. Place a support under the rear of the A-frame during storage to prevent any inadvertent movement of the plow from tipping the stand allowing the rear of the A-frame to fall.

3. To avoid corrosion during storage, coat the exposed (chrome) portion of the lift and angle cylinders with a light grease.

4. Grease all pivot points.

5. Top off Hydraulic reservoir to minimize trapped air.

6. Make sure that protective Caps are on all electrical connections. A small amount of dielectric grease may be used to insure a moisture proof seal on the Caps.

7. Check and replace any worn and/or damaged component, such as cutting edges or deflectors. Performing preventative maintenance tasks in the spring when plow is stored will ensure that you will be ready to plow in the fall.

# TROUBLE SHOOTING GUIDE

## Introduction

Whenever service is necessary, your local dealer knows your plow best and is interested in your complete satisfaction. Return your Snow Plow to your local dealer for Maintenance service or any other assistance you may require. If you are unable to do so, this Trouble Shooting Guide should help you determine the problem. Also, there are Repair Manuals available from your local dealer. However, before attempting the servicing of your plow, you should possess good mechanical abilities and a total understanding of the mechanism.



## CAUTION

**First read all warning instruction, the safety messages, and directions before attempting any adjustments or repairs to your unit!**

PLEASE: Before calling parts and service personnel be certain that:

1. You have read this guide carefully and are certain that all of the suggestions pertaining to your problem have been attempted.
2. You have the following information available.
  - A. Date Snow Plow was originally installed.
  - B. Power Pack Model Number.
  - C. Power Pack Serial Number.
  - D. Controller Serial Number.
  - E. Blade Model Number.
  - F. Blade Serial Numbers.
  - G. Pump Serial Number.

This information should be recorded on page 2 of this Owners Manual.

## Trouble Shooting-Quick Reference General

1. Check to see that vehicle ignition switch is "on" or in "run" position.
2. Check, and replace if necessary, accessory fuse in vehicle fuse panel.
3. Check all wiring to be sure that battery terminals are clean and connections to battery, circuit breaker, solenoid, switches and all connectors on plow harness are clean and tight.
4. Check oil level in hydraulic system reservoir.
5. Check for external leakage at cylinders, hoses and power unit.
6. Check the voltage at the coils which operate the solenoid valves to be sure that the voltage at the coils is a minimum of 9-1/2 volts DC.

# TROUBLESHOOTING

PROBLEM	PROBABLE CAUSE	CORRECTIVE ACTION
<b>Plow will not lift (Motor runs)</b>	Hydraulic fluid level low	See Maintenance Section
	Defective Raise/Lower Switch	Refer to Dealer
	Improper main pressure relief valve pressure setting, debris causing valve to stick	Refer to Dealer
	Breather cap plugged	See Maintenance Section
	Faulty raise/lower solenoid coil	Refer to Dealer
	Raise/lower solenoid valve stuck in lower position	Refer to Dealer
	Raise/lower cylinder frozen or binding	Refer to Dealer
	Defective or sticking Down Pressure Solenoid Valve	Refer to Dealer
	Diode in vehicle harness defective or missing	Refer to Dealer
	Pick-up tube filter plugged	See Maintenance Section
	Pick-up tube is not submerged in fluid	See Maintenance Section
<b>Motor continues to run and will not shut-off</b>	Machine failure	Refer to Dealer
	Motor Solenoid defective	Refer to Dealer
<b>Plow lifts slowly</b>	Machine defective	Refer to Dealer
	Hydraulic fluid level low	See Maintenance Section
	Breather cap plugged	See Maintenance Section
	Improper main relief pressure setting, debris causing valve to stick	Refer to Dealer
	Pick-up tube filter plugged	See Maintenance Section
	Improper oil viscosity for outside air temperature, unit not at normal operating temperature	See Maintenance Section
	Defective Lift Cylinder	Refer to Dealer
Machine failure	Refer to Dealer	

# TROUBLESHOOTING

PROBLEM	PROBABLE CAUSE	CORRECTIVE ACTION
<b>Fluid leaking at Pump Assembly</b>	Hydraulic fittings not torqued properly (too tight, too loose)	Refer to Dealer
	O-Rings between valve block and endhead are worn or not seating properly	Refer to Dealer
	O-Rings between endhead and reservoir worn or not seating properly	Refer to Dealer
	Reservoir over-full	See Maintenance Section
	O-Ring on solenoids or pressure switches defective	Refer to Dealer
	Endhead cracked	Refer to Dealer
	Valve body cracked	Refer to Dealer
<b>Unit lifts but does not hold - first action</b>	Dirt in check valve or lower solenoid valve	Cycle raise and lower system to flush debris
	Lower solenoid valve sticking	Cycle raise and lower system to unstick valve
<b>Unit lifts but does not hold - second action</b>	Dirt or debris in check valve	Refer to Dealer
	Check valve spring broken	Refer to Dealer
	Raise/lower solenoid valve sticking	Refer to Dealer
	Seals O-Ring(s) on raise/lower solenoid valve or down pressure solenoid valve damaged	Refer to Dealer
	Current available at raise/lower solenoid without switch function	Refer to Dealer
	Raise /lower ram defective allowing movement in one direction only	Refer to Dealer
	Machine failure	Refer to Dealer
<b>Unit will not lower</b>  <i>NOTE: Only in Non- down pressure mode</i>	Plugged breather cap	See Maintenance Section
	Low or no current available at raise/lower Solenoid	Refer to Dealer
	Raise/lower solenoid valve sticking	Refer to Dealer
	Raise/lower solenoid coil defective	Refer to Dealer
	Raise lower ram defective allowing movement in one direction only	Refer to Dealer
	Machine failure	Refer to Dealer

# TROUBLESHOOTING

PROBLEM	PROBABLE CAUSE	CORRECTIVE ACTION
<b>Unit will not lower</b>  <i>NOTE: In down pressure mode only</i>	See all above conditions	Refer to Dealer
	Raise lower ram defective allowing movement in one direction only	Refer to Dealer
	Defective down pressure switch in Control Box	Refer to Dealer
	Defective down pressure solenoid	Refer to Dealer
	Machine failure	Refer to Dealer
<b>Motor will not run</b>	Motor brushes worn/commutator worn or dirty	Refer to Dealer
	Seal between motor and pump defective allowing oil to enter motor housing	Refer to Dealer
	Defective Start Solenoid	Refer to Dealer
	Motor seized	Refer to Dealer
	Machine failure	Refer to Dealer
<b>Blade wing moves in one direction only</b>	Solenoid valve sticking or defective	Refer to Dealer
	Crossover relief valve defective or sticking	Refer to Dealer
	Low or no current available at extend or retract solenoid valve	Refer to Dealer
	Crossover relief valve pressure setting too low	Refer to Dealer
	Angle cylinder defective allowing movement in one direction only	Refer to Dealer
	Machine failure	Refer to Dealer
<b>Blade wing will not move</b>	Hydraulic fluid level low	See Maintenance Section
	Crossover pressure relief valve setting too low	Refer to Dealer
	Solenoid valve sticking or defective	Refer to Dealer
	Low or no current available at solenoid valve	Refer to Dealer
	Wing cylinder binding or frozen	Refer to Dealer
	Pick up tube not submerged in fluid	See Maintenance Section
	Machine failure	Refer to Dealer

# TROUBLESHOOTING

PROBLEM	PROBABLE CAUSE	CORRECTIVE ACTION
<b>Blade wing will not move, but plow raises when trying to move wings</b>	<b>Main power solenoid defective or sticking</b>	<b>Refer to Dealer</b>
	<b>Low or no current available at main power solenoid valve</b>	<b>Refer to Dealer</b>
<b>Blade wing moves very slowly</b>	<b>Hydraulic fluid level low</b>	<b>See Maintenance Section</b>
	<b>Crossover Relief Valve defective or sticking</b>	<b>Refer to Dealer</b>
	<b>Crossover Relief Valve pressure setting to low</b>	<b>Refer to Dealer</b>
	<b>Improper oil viscosity for outside air temperature, unit not at normal operating temperature</b>	<b>See Maintenance Section</b>
	<b>Defective Wing Cylinder</b>	<b>Refer to Dealer</b>
	<b>Dirt or debris in Solenoid Valve</b>	<b>Refer to Dealer</b>
<b>Blade wings will not hold position (fold rearward)</b>	<b>Defective or dirt/debris in Wing Relief Valve</b>	<b>Refer to Dealer</b>
	<b>Defective or sticking Solenoid Valve</b>	<b>Refer to Dealer</b>
	<b>Dirt or debris in Solenoid Valve</b>	<b>Refer to Dealer</b>
	<b>Defective Wing Cylinder</b>	<b>Refer to Dealer</b>

# MAINTENANCE

## General

- Before operating, perform a thorough visual inspection of the equipment. Look for fluid leaks, cracked, bent or broken components, loose nuts, bolts or attachments and proper fluid levels.

- A clean hydraulic system is essential to long pump life and proper performance.

- When adding oil to the reservoir, wipe the area around the filler port clean before removing the breather cap. Use clean oil and a clean funnel, (DO NOT use a cloth or rag to strain the oil).

**IMPORTANT:** Hydraulic unit comes from factory charged with Type 5606. If additional oil is added it must be compatible with Type 5606. If another type of oil has been used in the system the same type of oil must be used for topping off system. Improper hydraulic fluid can cause operating problems in cold weather.

- The operational environment for Snow Plows is an extremely harsh and corrosive one.

- Ensure all electrical connections are clean and tight.

- To prevent rust from forming, clean and repaint exposed metal surfaces.

- NEVER operate the equipment with the protective covers or guards removed.

## Periodic Inspection

After approximately every 20 hours of operation perform the following inspections procedures:

1. Inspect the plow assembly including the Subframe assembly for any damage or excessive wear. Also inspect all fasteners to insure that they are properly tightened. If any fasteners are loose re-tighten to the proper torque (Refer to the Torque Specification chart in this manual). Also carefully inspect adjacent area for damage or wear as well as carefully inspecting all adjacent fasteners for proper torque.

2. Apply a small amount of light oil to the Hitch Pins and pivots, to Pivot Pins between the Center Blade Assembly and the Intermediate Pivot Assembly, between Lift and Swing Cylinder pivot Pins and the Lift Linkage Pivots.

3. Lubricate the Wing Pivot Shafts with a good quality HP Lithium based grease.

*NOTE: For extremely cold weather plowing, continuous sub Zero operation, an alternative is to remove the grease fittings and fill the grease cavity with SAE 140 Gear Oil, and then replace the grease fitting.*

## Special Fasteners Torques and Requirements

**IMPORTANT:** Incorrectly securing fasteners may result in incorrect operation, excessive wear, and early failure of plow components. It may also void your warranty.

- ALWAYS check to make sure you are using the correct Torque specification for the fastener you are using.

- DO NOT use any lubricants on the threads of any fastener unless specifically called for in the assembly or maintenance story for that component.

- NEVER use liquid locking materials, such as Loctite™ or Threadmaker™, on any fasteners unless specifically called for in an assembly or maintenance story for that component.

### Standard Fasteners:

The Torque Specifications Chart on page 25 of this manual should be used as the guide for fastener Torque requirements for most standard fasteners used on the plow.

Standard fasteners with special Torque requirements will be noted in assembly or service stories pertaining to the specific piece of equipment.

### Hydraulic Fittings:

Hydraulic fittings with lock nuts should be assembled with at least three full turns of the fitting in the port and then the lock nut should be tightened to 27 lb.-ft.

### Wing Cylinder Attaching Fasteners:

Base end and Rod end attachment cap screws are always assembled with the cap screw head UP.

Always use a Nylock nut and only Torque the nut to 25 to 30 lb.-ft. DO NOT overtighten these fasteners. Overtightening of wing cylinder attachment fasteners may bind cylinder and cause excessive cylinder wear and/or restrict wing movement.

### Bellcrank Assembly to Lift Arm Assembly Fasteners:

Apply Loctite 242™ (Blue) to the threads of the cap screws and tighten the jam nut to 70 lb.-ft. Then place the lock nut on the cap screw and tighten to 70 lb.-ft.

### Pivot Frame Assembly:

Install the 1" Slotted Nut on the threaded end of the Special Screw and tighten finger tight. Then tighten the nut another 2/3 to 1 full turn and line up a slot in the nut with the cross hole in the Special Screw. Install the 3/16"x2" Cotter Pin in the Special Screw and spread the ends of the Cotter Pin.

### Hydraulic Cylinders

To avoid corrosion during storage, coat the exposed (chrome) portion of the lift and angle cylinders with a light grease.

### Electrical Quick Disconnect Plugs

Install protective Caps on quick disconnect ends to prevent corrosion from forming on terminal ends during storage or when plow is disconnected from vehicle.

### Service Intervals

It is recommended to change the fluid in the hydraulic system once a season.

### Fluid Requirements

**IMPORTANT:** Hydraulic unit comes from factory charged with Type 5606. If additional oil is added it must be compatible with Type 5606.

*NOTE: when Type 5606 is not available Exxon UNIVIS J13 or equivalent may be used.*



- Using the proper oil increases the life expectancy of the most critical part of your plow; the Hydraulic power unit.
- Failure to use the proper oil can cause extensive damage to the power unit, seals and hydraulic rams.
- Improper oil can cause operating problems and poor performance in cold weather.

### Changing Oil and Cleaning Filter Screen



**Using the proper oil increases the life expectancy of the most critical part of your unit; the Hydraulic power unit.**

*NOTE: We recommend cleaning the filter screen and magnet at every oil change, this will help ensure maximum life and maximum performance from the pump assembly.*



- **Allow the system to cool down before draining oil or handling system components. Serious burns can result from contact with hot oil.**
- **Never disconnect any hydraulic line or fitting with the unit in the raised position. Always lower the unit and relieve pressure before removing any lines or caps.**

**FAILURE TO HEED CAN RESULT IN SERIOUS INJURY OR DEATH.**

1. Lower plow assembly to ground, put vehicle in park and turn off engine.



**Ensure Engine is OFF and set parking brake before working on Plow. Vehicle movement, equipment failure or inadvertent operation of the control switches during maintenance could result in serious injury**

**FAILURE TO HEED CAN RESULT IN SERIOUS INJURY OR DEATH.**

2. Loosen four Nylock Nuts attaching Pump Cover to frame. Remove the pump cover taking care not to disconnect wires to Rocker Switch mounted in Pump Cover.

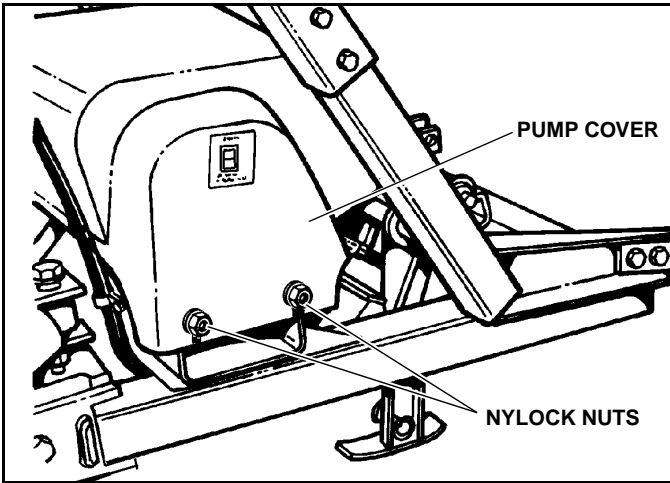

**Figure 2-1**

3. Remove the Filler/Breather Cap from the Reservoir.  
(See Figure 2-2)

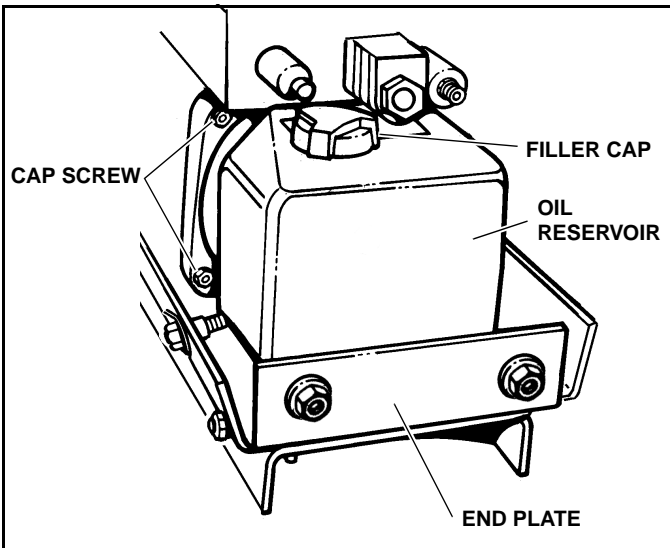

**Figure 2-2**

4. Using an oil suction gun or similar tool, remove the oil from the Oil Reservoir.

*NOTE: Be careful to avoid contacting and damaging the Filter screen while removing the oil.*

5. Remove two (2) cap screws securing Pump Platform End Plate to Pump Platform. (End Plate is located next to end of Oil Reservoir.)

6. Remove the four cap screws securing the Oil Reservoir to the pump assembly and remove the Oil Reservoir being careful not to damage the Filter screen while removing the Oil Reservoir. (See Figure 2-2)

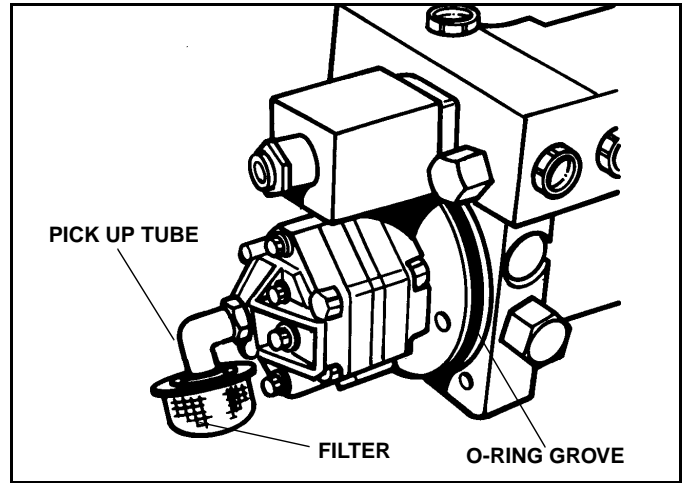

**Figure 2-3**

7. Unscrew the Filter Screen (hold it by the metal cover, not by the screen) and clean it with a suitable solvent. Blow dry with low pressure compressed air from the inside.

8. Carefully reinstall the Filter Screen. Tighten it by hand to avoid damaging the threads of the nylon pick-up tube.

9. Visually check that the pickup tube and filter face down. (See Figure 2-3) If not, rotate the pickup tube until the tube and filter face down.

10. Clean the Oil Reservoir inside and out with a suitable solvent.

11. Remove the Magnet from the side of the pump and carefully remove any metal particles from the Magnet and place the Magnet back on the side of the pump. (See Figure 2-3)

12. Inspect the O-Ring Seal for damage, replace if needed, lubricate with fresh oil and reinstall reservoir carefully to avoid damaging the O-Ring. Tighten cap screws to 4-6 lb.-ft.

13. Mark hydraulic fittings for position and location on both angle and lift cylinders and carefully disconnect them.

*NOTE: Do not loosen fitting in cylinder body. Loosen only at connection with hose.(See Figure 2-4)*

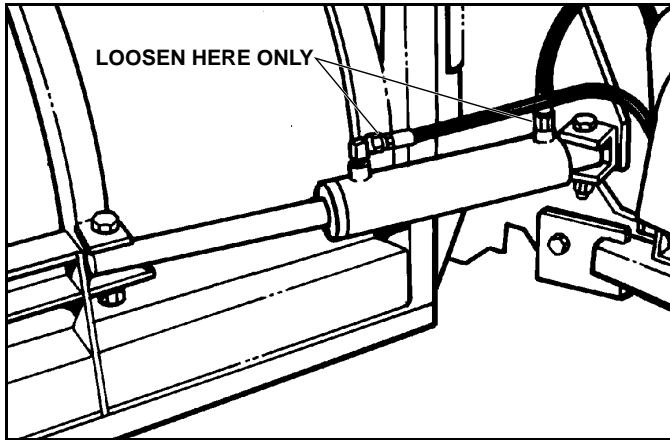

Figure 2-4

14. Manually work the two Angle and Lift Cylinders through their entire range of motion in order to drain the fluid remaining in the Cylinders.
15. Reconnect hydraulic fittings in their correct position and Torque to 20-25 lb.-ft. If unit utilizes O-Ring and jam nut type connectors tighten jam nut to 15-20 lb.-ft.



## CAUTION

**Do Not use Teflon® tape or Pipe Dope on hydraulic fittings. These can dislodge and jam valves in the hydraulic system.**

16. Fill the hydraulic Oil Reservoir until the fluid level registers full on Oil Level Mark on Oil Reservoir.

*NOTE: Vehicle must be parked on level ground, Plow must be in the lowered position, and Wings must be folded rearward ("V") in order to properly check the oil level. Checking oil level with plow elevated or with Wings straight or folded forward will give wrong reading.*

17. Refer to plow operation instructions and operate the plow to purge all air from the hydraulic system.
18. Replenish the fluid in the reservoir until the fluid level registers full on Oil Level Mark on Oil Reservoir.
19. Operate system and check for leaks, repair or tighten as necessary.

## Disk Shoe Adjustment

**IMPORTANT:** This Plow is equipped with three (3) Disk Shoes. Two Disk Shoes are located at the outboard end of each Wing. The third Disk Shoe is located under the Trip Springs on the Center Plow Assembly. All three Disk Shoes must be adjusted equally.

**IMPORTANT:** To ensure the best function of this Snow plow, it is a requirement that all three Disk Shoes be used at ALL times.

1. Drive the vehicle, with Snow Plow mounted, onto a smooth, level surface. Park the vehicle, move the Plow Wings until the Wings are straight out on each side and lower the Plow to the ground.
2. Turn ignition switch OFF and apply the emergency brake.
3. Inspect both Float Limiter Screws and be sure that the hex head of the screws are not contacting the wear plate underneath the hex head of the screw. If necessary, adjust each screw upward so that the screw head is not contacting the wear plate when the pivot tubes are vertical.

*NOTE: After Disk Shoe Adjustment is completed, the Float Limiter Adjustment must be made. See "Float Limiter Adjustment" on page 22*

4. Place a level against the front of the Wing Pivot Tubes and pull or push the top of the Center Section until the level indicates that the Pivot Tubes are vertical (Not tipped either forward or rearward).
5. Determine whether the Center Disk Shoe or the Center Wearstrip is off the ground and measure the amount that it is off the ground. (See Figure 2-5)

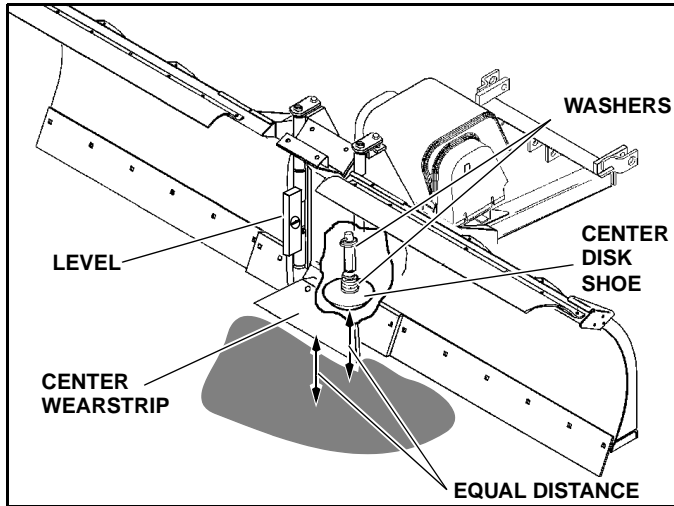

**Figure 2-5**

*NOTE: Gap may be measured by sliding shims or washers between the ground and/or the Center Disk Shoe or the Center Wearstrip, then measuring the shim/washer stack. The Center Disk Shoe will need to be adjusted until the Disk Shoe and Center Wearstrip both contact the ground at the same time.*

- If the Center Disk Shoe was off the ground - Washers must be ADDED below the Disk Shoe Mounting Tube.
- If the Center Wearstrip was off the ground - Washers must be REMOVED from below the Disk Shoe Mounting Tube.

**IMPORTANT: If Washers must be added, add one Washer LESS than the amount the Disk Shoe was off the ground. If Washers must be removed, remove one Washer MORE than the amount the Wearstrip was off the ground.**

6. Raise Plow and place suitable blocking under the Plow to allow at least eight inches (8") of clearance from the bottom of the Center Disk Shoe to the ground.

7. Lower Plow onto blocking.



## WARNING

**Keep hands and feet clear of Wings and Center Section when setting blocking and lowering Plow. Moving or falling assemblies could result in serious injury.**

**FAILURE TO HEED CAN RESULT IN SERIOUS INJURY OR DEATH.**

8. Adjust Center Disk Shoe assembly by removing the Disk Shoe Mounting Pin and adding or subtracting Washers on the top or bottom of the Disk Shoe Mounting Bracket as required according to measurements taken in step #4.

9. After the Center Disk Shoe position is properly adjusted, place washers on the Disk Shoe Stem - above the Disk Shoe Mounting Bracket, and below the Retaining Pin - to remove all up and down movement of the Disk Shoe in the Bracket. Failure to do this will result in excessive wear of the holes in the Disk Shoe Mounting Bracket and will also result in bending the Disk Shoe Stem.

10. After the Center Disk Shoe adjustment is completed, lower the Plow to the ground. If this Disk Shoe adjustment is correct, the Center Disk Shoe and the Center Wearstrip will both be on the ground and the Wing Tubes will be vertical (Recheck the Wing Tubes with a level). If Wing Tubes are not vertical, repeat steps #3 to #9 until Wing Tubes are vertical.

*NOTE: If assembling and mounting a Snow Plow for the first time, the adjustment of the Center Disk Shoe can be done with just the Center Section Mounted on the vehicle, prior to assembling the Wings onto the Center Section of the Plow.*

11. With each Wing extended straight out to each side, measure the amount the Wing Shoes are off the ground, or if they are on the ground, measure the amount that the Wearstrip is off the ground (measured in front of the Disk Shoe Bracket).

12. Raise Plow and place suitable blocking under the Plow to allow at least six inches (6") of clearance from the bottom of the Wing Disk Shoes to the ground.

13. Lower Plow onto blocking.



## WARNING

Keep hands and feet clear of Wings and Center Section when setting blocking and lowering Plow. Moving or falling assemblies could result in serious injury.

**FAILURE TO HEED CAN RESULT IN SERIOUS INJURY OR DEATH.**

14. Adjust each Disk Shoe assembly by removing Disk Shoe mounting Pin and adding or subtracting Washers on the top or bottom of the Disk Shoe Mounting Bracket as required according to measurements taken in step #11 (See Figure 2-6)

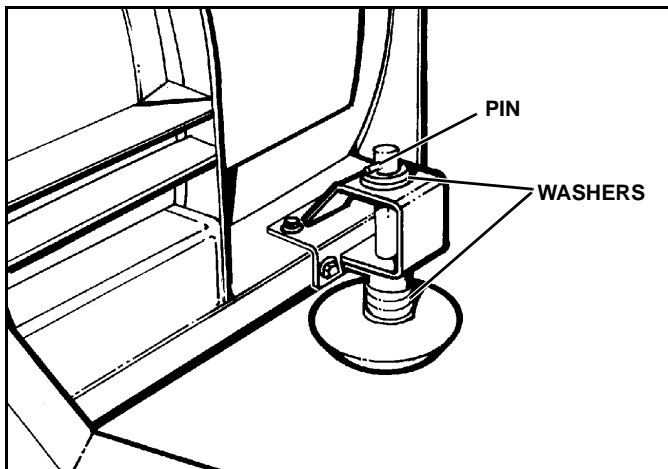

Figure 2-6

15. After the Disk Shoe position is properly adjusted, place washers on the Disk Shoe Stem - above the Disk Shoe Mounting Bracket, and below the Retaining Pin - to remove all up and down movement of the Disk Shoe in the Bracket. Failure to do this will result in excessive wear of the holes in the Disk Shoe Mounting Bracket and will also result in bending the stem of the Disk Shoe.

16. After the Wing Disk Shoe adjustment is complete, lower the Plow to the ground. If this Disk Shoe adjustment is correct, the Shoes and the Wearstrips will all be on the ground at the same time, if not, repeat steps #11 to #15.

17. Move the Wings forward and rearward. If the Wing Wearstrips and the Center Wearstrips are not on the ground at all times recheck the position of the Wing Pivot Tubes. The Tubes must be Vertical, if they are not vertical, the Center Disk Shoe will need to be adjusted.

## Float Limiter Adjustment

**IMPORTANT:** The Disk Shoes must be properly adjusted prior to adjusting the Float Limiter. If the shoes are not properly adjusted, the Float Limiter Adjustment cannot be properly made.

1. With the vehicle and Snow Plow on a smooth, level surface move the Wings forward into the "Scoop" position and lower the Plow to the ground.

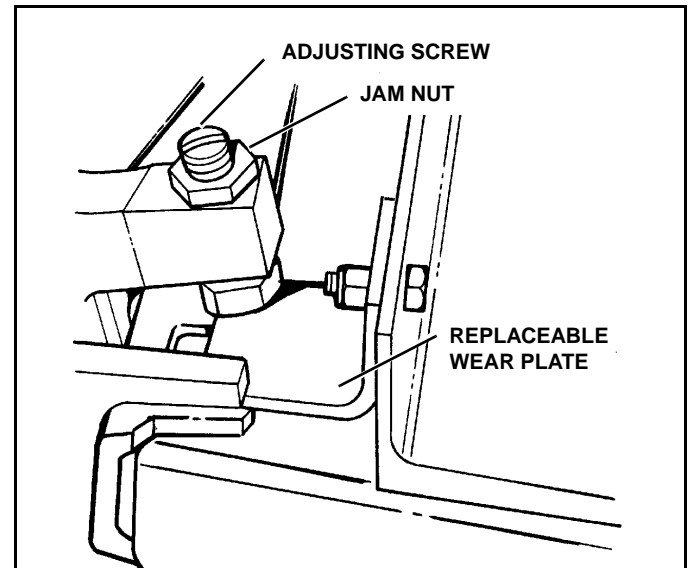

Figure 2-7

2. Loosen the 5/8" Jam Nut on the top of the float limiter Adjusting Screw.

3. Using the screwdriver slot in the top of the Float Limiter Adjusting Screw, turn the Adjusting Screw down until the hex head of the Adjusting Screw touches the surface of the replaceable Wear Plate.

4. Turn the Adjusting Screw up two turns to provide a gap between the wear plate and the head of the Adjusting Screw for proper float allowance.

5. While holding the Adjusting Screw driver slot, to prevent turning of the Adjusting Screw, tighten the 5/8" Jam Nut to lock the Adjusting Screw and prevent turning of the Adjusting Screw during operation.

## Pivot Assembly Pivot Screws

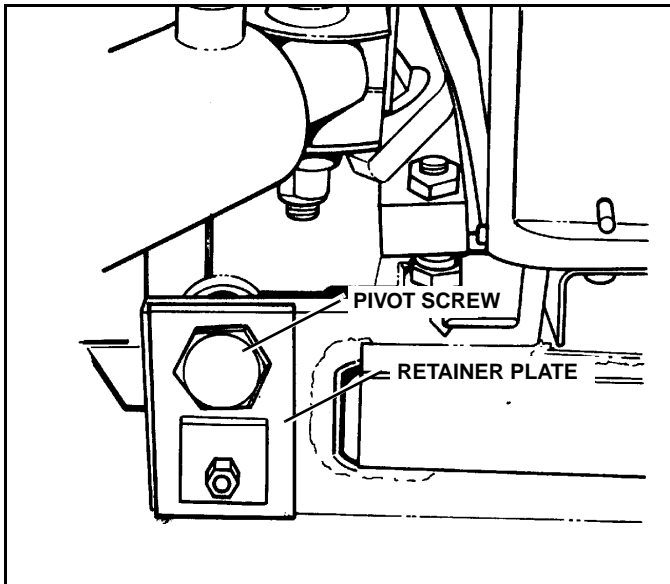

Figure 2-8

1. The hex head of the Pivot Screw must be seated within the hex opening of the Retainer Plate.

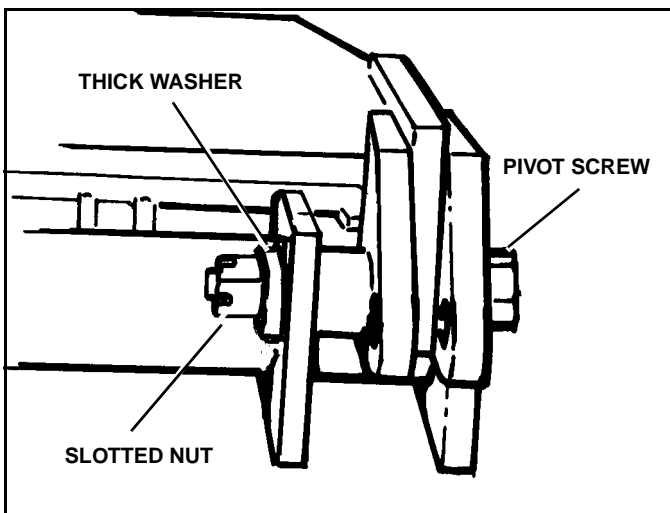

Figure 2-9

2. Install the special 1/4" Thick Washer on the threaded end of the Pivot Screw and install the 1" Slotted Nut finger tight. Then tighten the nut an additional 2/3 to 1 full turn and line up a slot in the nut with the cross hole in the Pivot Screw. Install a 3/16"x2" Cotter Pin through the slot in the Slotted Nut and the cross hole in the Pivot Screw and spread both Cotter Pin ends.

## Cutting Edge

*NOTE: Cutting Edge must be replaced when it is worn to the bottom edge of the frame.*

1. Raise the Plow to the full UP position.
2. Place suitable blocking under A-Frame of plow to allow at least 6" of clearance from the Blade to the ground.

**IMPORTANT:** Make sure to position blocking away from Cutting Edge so that when plow is lowered onto blocking Cutting Edges do not rest on blocking.

3. Lower Plow onto blocking.



## WARNING

Keep hands and feet clear of Wings and A-Frame when setting blocking and lowering blade. Moving or falling assemblies could result in serious injury.

**FAILURE TO HEED CAN RESULT IN SERIOUS INJURY OR DEATH.**



## CAUTION

Cutting Edges may be sharp. Always wear gloves and handle Cutting Edges with care to avoid injury.

4. Remove mounting bolts holding old Center Cutting Edge and Short Inner Wing Cutting Edges to Blade. Discard old Cutting Edges and hardware.

**IMPORTANT:** Do not remove Long Wing Cutting Edges at this time. Short Inner Cutting Edges must be installed before removal of Long Wing Cutting Edges.

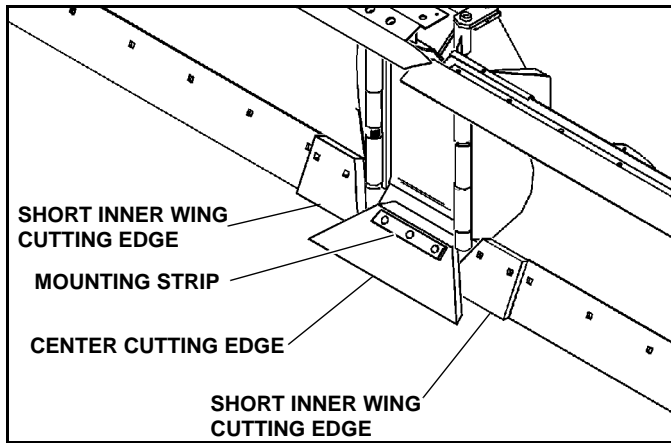

Figure 2-10

5. Install new Short Inner Cutting Edges using new hardware.

*NOTE: The Blade Skin must be retained prior to removing the Long Wing Cutting Edges. This can be accomplished by using a 6" C-Clamp located at the center of the curved portion of the Blade Skin at the outer end of the Wing. The Short Inner Cutting Edges will retain the inner end of the Blade Skin.*

6. Remove the mounting bolts holding the old Long Wing Cutting Edges to the Blade Wings. Discard old Cutting Edges and hardware.

7. Install new Long Wing Cutting Edges using new hardware.

8. Install new Center Cutting Edge and secure with new Mounting Strip and new hardware. Torque the three Center Cutting Edge fasteners to 50 lb.-ft.

## Trip Spring Adjustment

*NOTE: The Trip Springs are factory installed and adjusted, but adjustment should be checked during Plow Set-Up and installation.*

The Springs are properly adjusted when the coils begin to separate.

If readjustment is required:

1. Raise the plow to transport position and place blocking under the plow to prevent the plow from inadvertently dropping.

2. Turn off the vehicle ignition, apply the parking brake and remove the vehicle ignition key.

3. Check to make sure that the Spring is installed as illustrated with open end of top loop facing vehicle. (See Figure 2-11)

4. Using a 15/16" socket wrench through the holes in the Bottom Plate of the Main Frame, loosen the two (2) 5/8" Nuts on the Trip Spring Eyebolts. (See Figure 2-11)

5. After the two lower nuts have been loosened, the two upper nuts can be rotated on the eye bolts to allow the Trip Springs to be shortened or lengthened.

6. While holding the two upper nuts, re-tighten the two lower nuts and then re-check the spring adjustment.

*NOTE: Springs are properly adjusted when two or more coils allow a 0.010" feeler gauge to just pass between the separated coils. (A 3 x 5 post card is approximately the same thickness.)*



- Do not overtighten springs. If more than 0.015" (1/64") gap appears between coil with plow at rest damage could occur to equipment during plowing.

- Spring must be installed with open end of top loop facing vehicle. Bottom loop position will vary.

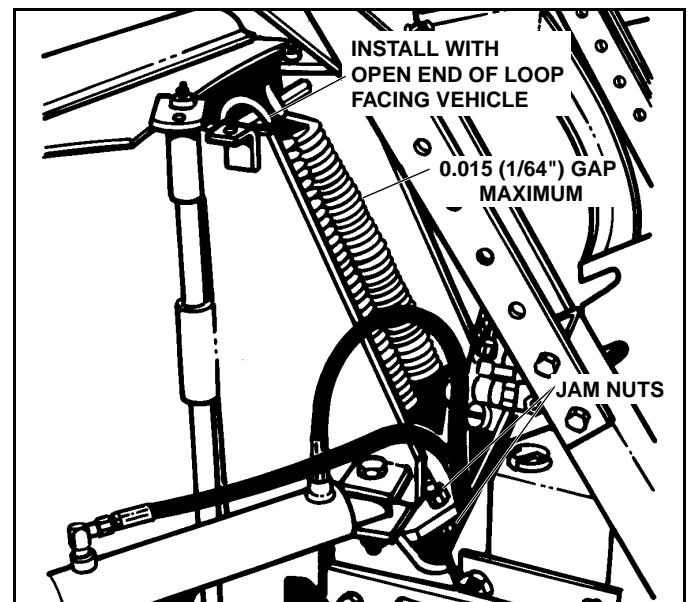

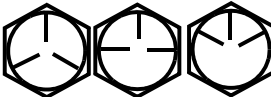





Figure 2-11

# TORQUE SPECIFICATIONS

SAE Grade and Head Markings	1 or 2 No Marks 	5    5.1    5.2 	8    8.2 
SAE Grade and Nut Markings	2 No Marks 	5 	8 

	Grade 1		Grade 2		Grade 5, 5.1 or 5.2		Grade 8 or 8.2	
	Lubricated <sup>a</sup>	Dry <sup>b</sup>	Lubricated <sup>a</sup>	Dry <sup>b</sup>	Lubricated <sup>a</sup>	Dry <sup>b</sup>	Lubricated <sup>a</sup>	Dry <sup>b</sup>
SIZE	lb-ft	lb-ft	lb-ft	lb-ft	lb-ft	lb-ft	lb-ft	lb-ft
8-32			14*	19*	22*	30*	31*	42*
10-24			21*	27*	32*	43*	45*	60*
1/4	2.8	3.5	4.5	5.5	7	9	10	12.5
5/16	5.5	7	9	11	15	18	21	26
3/8	10	13	16	20	26	33	36	46
7/16	16	20	26	32	41	52	58	75
1/2	25	31	39	50	63	80	90	115
9/16	36	45	56	70	90	115	130	160
5/8	50	62	78	100	125	160	160	225
3/4	87	110	140	175	225	280	310	400
7/8	140	175	140	175	360	450	500	650
1	210	270	210	270	540	675	750	975

DO NOT use these values if a different torque value or tightening procedure is given for a specific application.

Fasteners should be replaced with the same or higher grade. If higher grade fasteners are used, these should only be tightened to the strength of the original.

<sup>a</sup> "Lubricated" means coated with a lubricant such as engine oil, or fasteners with phosphate and oil coatings.

<sup>b</sup> "Dry" means plain or zinc plated without any lubrication

\* Values with asterisk are in lb-in.

# HYDRAULIC SCHEMATIC

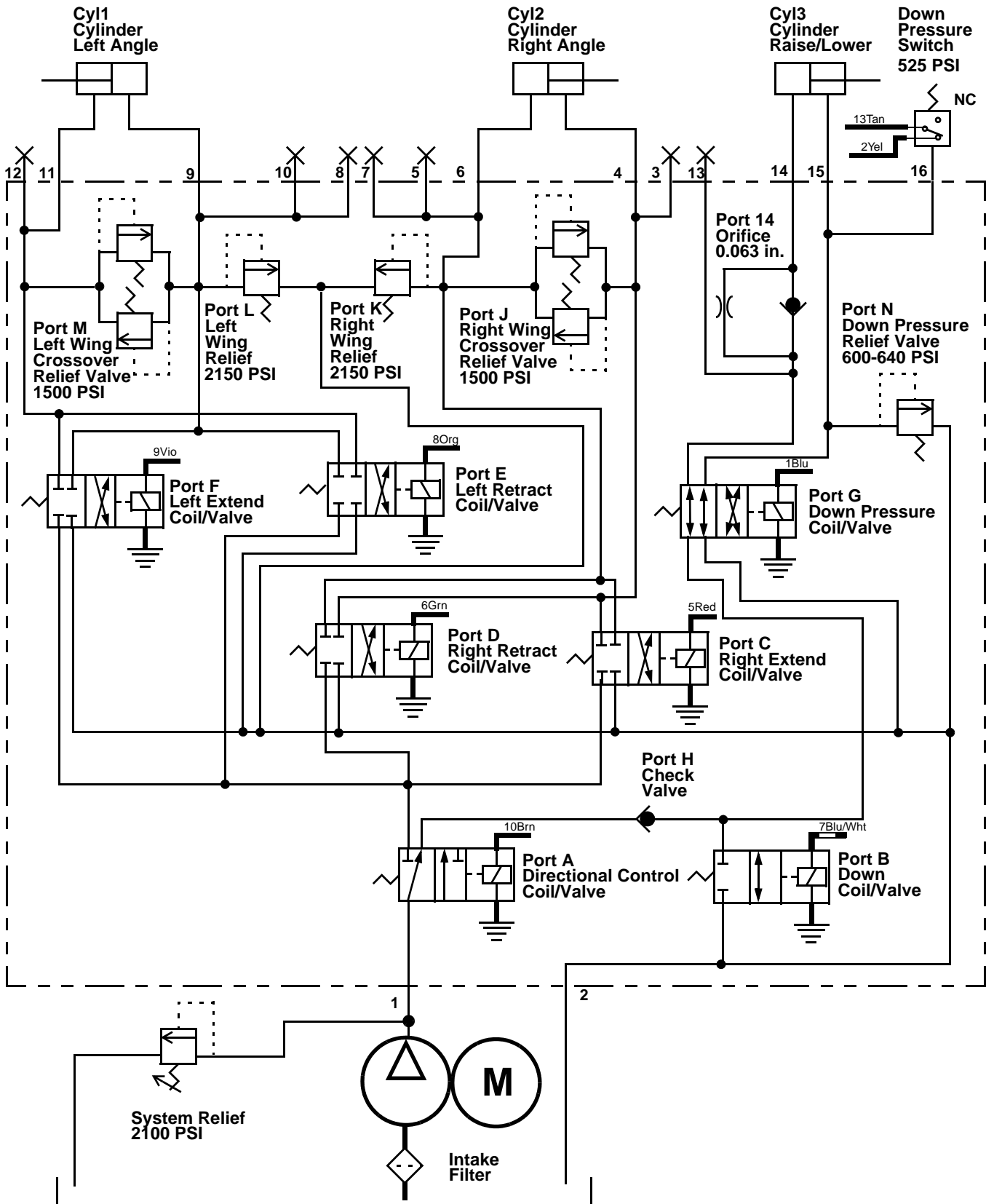

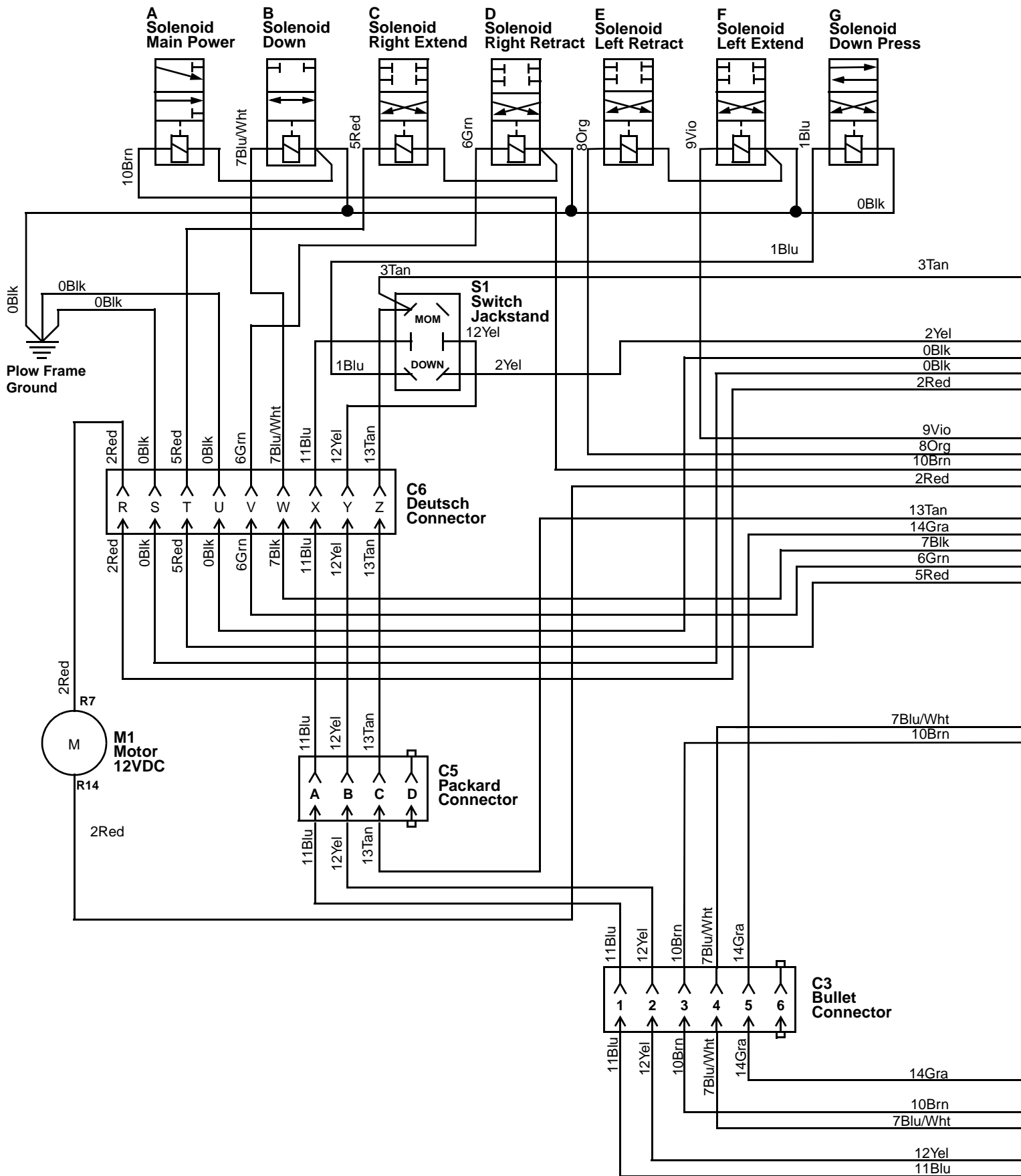



# W1 Wire Harness - Vehicle

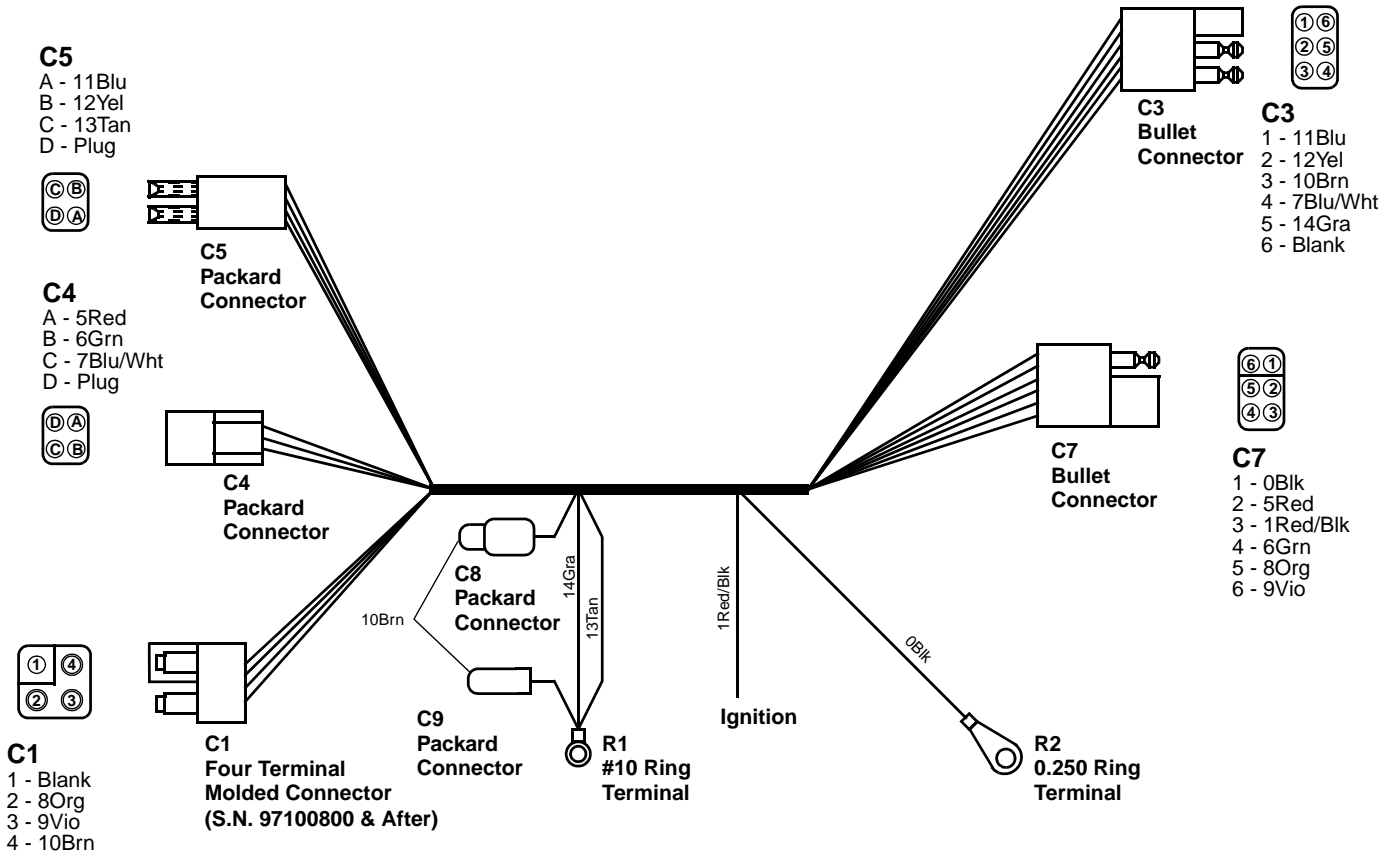

# W2 Wire Harness - Control Box "B"

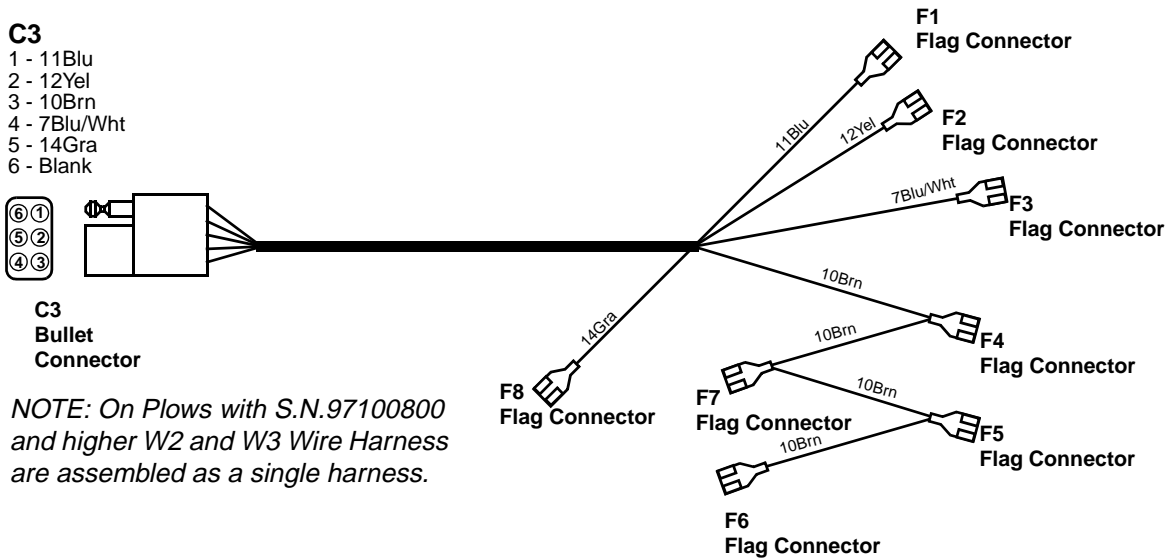

# W3 Wire Harness - Control Box "A"

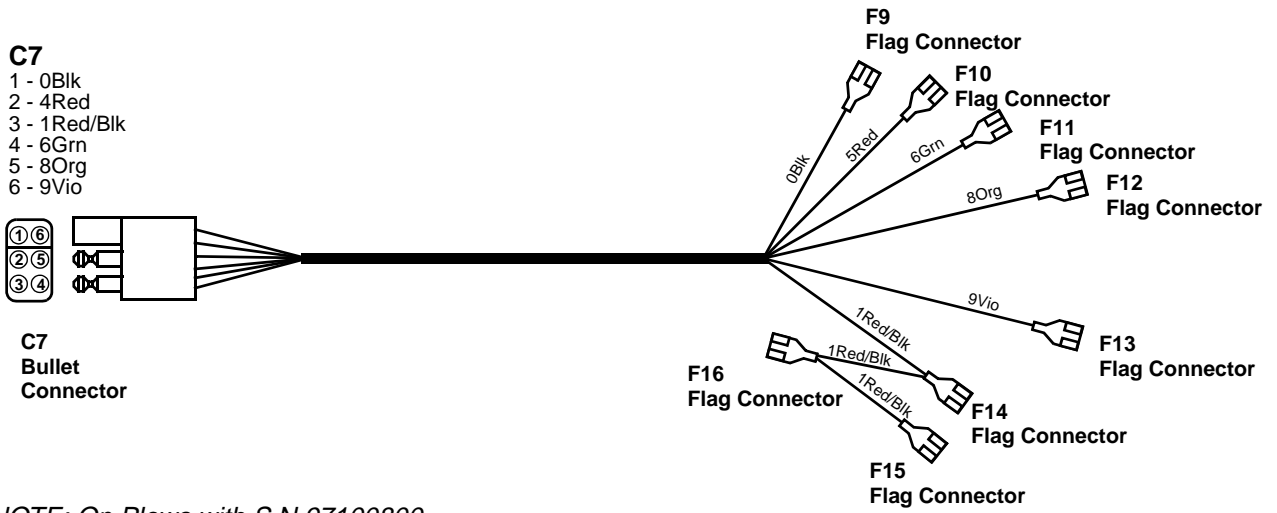

*NOTE: On Plows with S.N.97100800 and higher W2 and W3 Wire Harness are assembled as a single harness.*

# W4 Wire Harness - Vehicle End Control

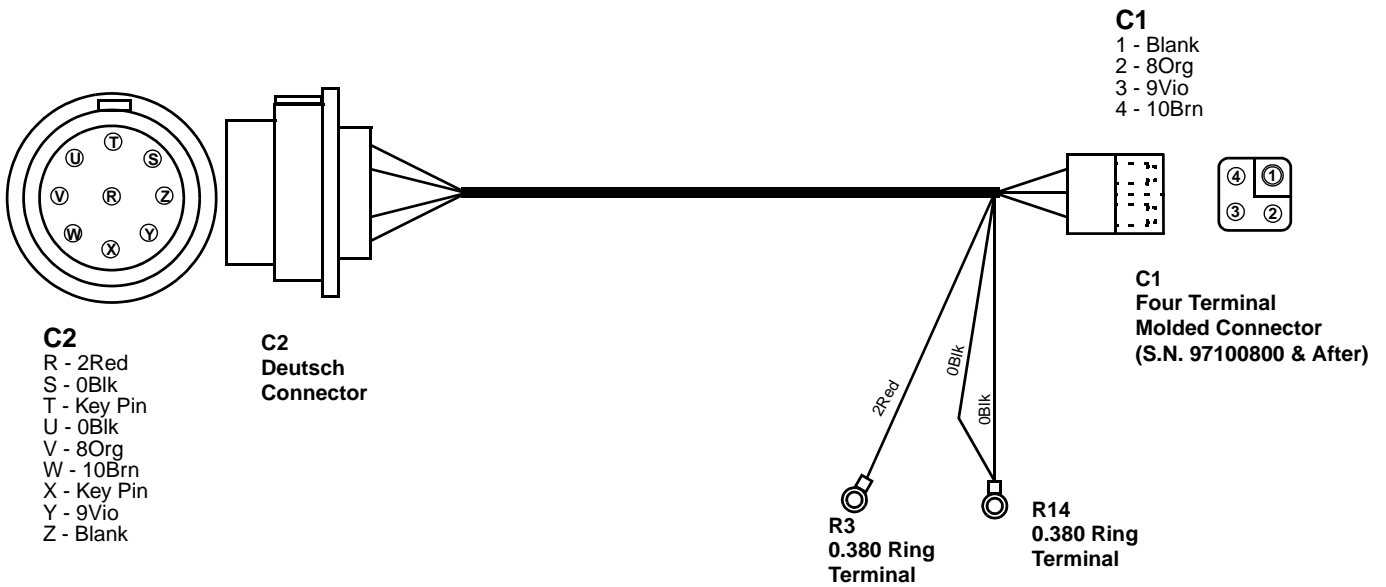

## W5 Wire Harness - Vehicle End

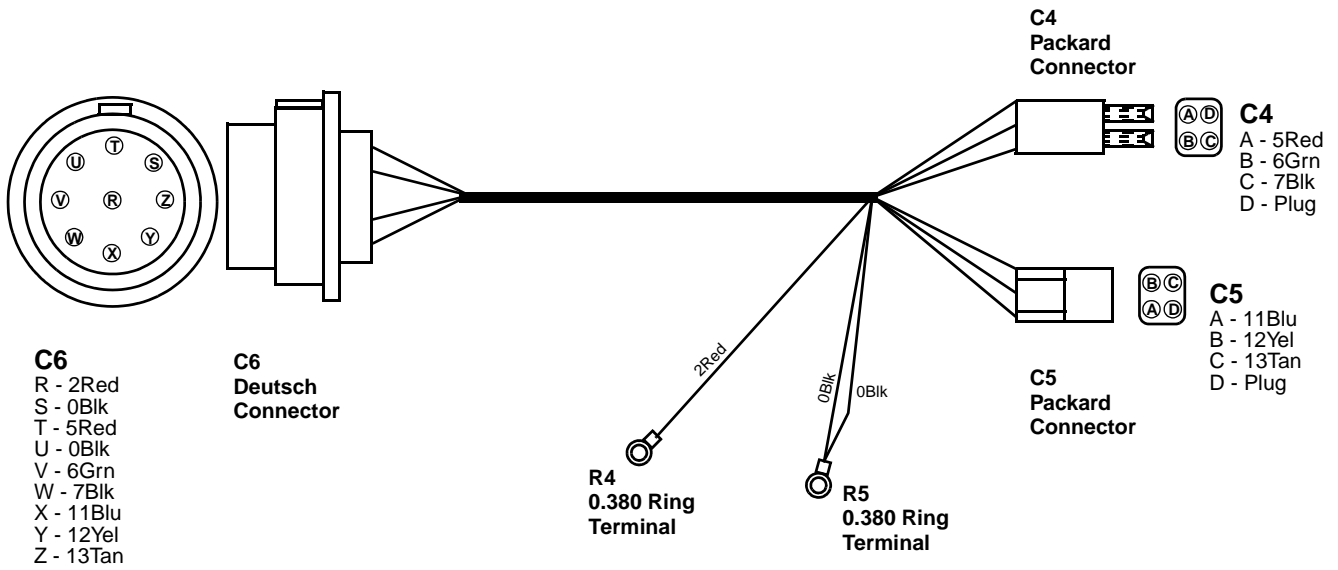

## W6 Wire Harness - Pump End Control

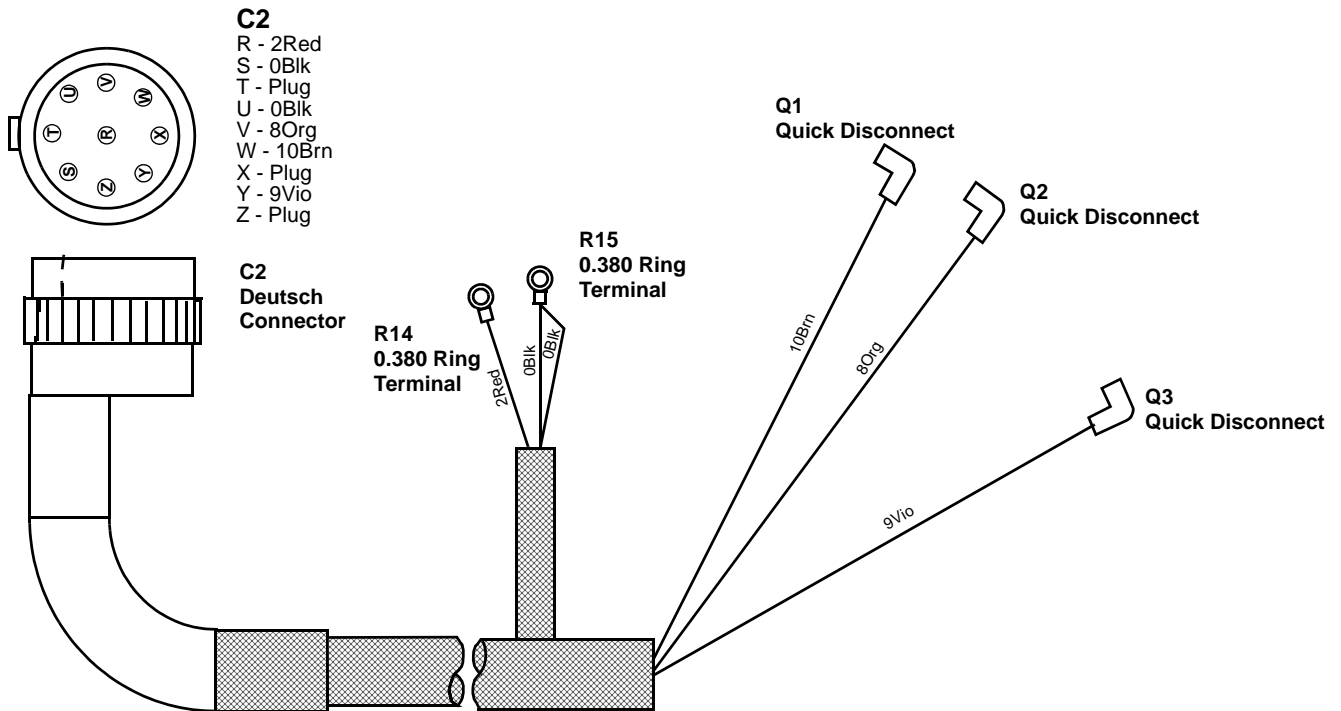

# W7 Wire Harness - Pump End Main

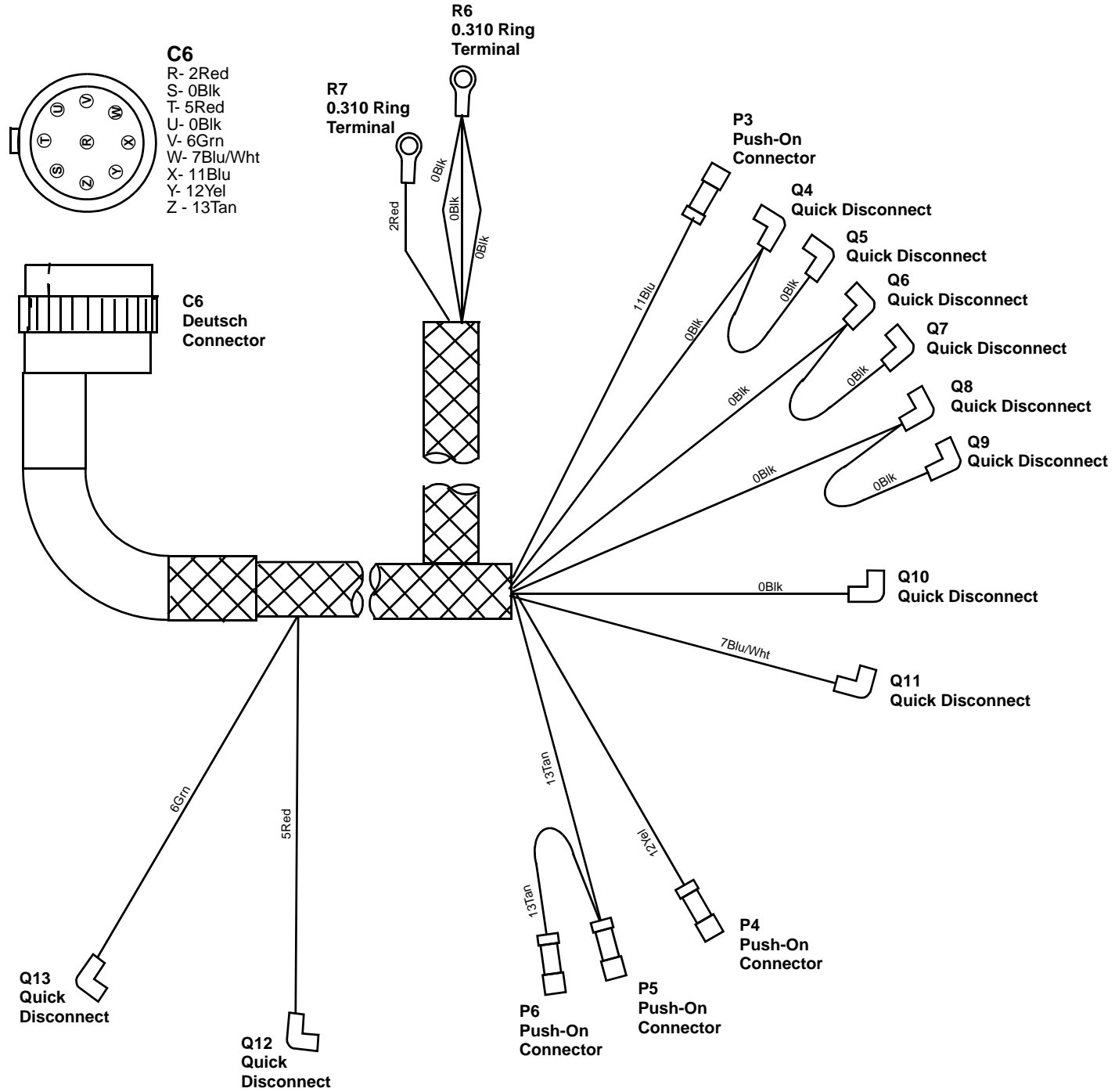

## W8 Wire Harness (No Longer Used)

### W9 Wire Harness - Battery Power



### W10 Wire Harness - Battery Ground

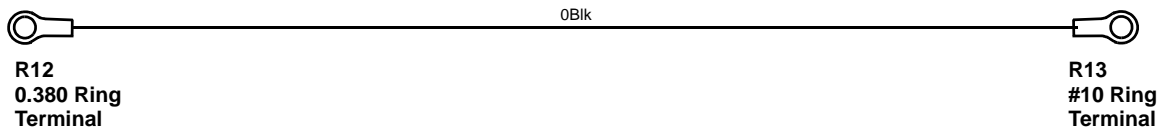

### W11 Wire Harness - Solenoid Switch Power



### W12 Wire Harness - Jackstand Switch Jumper

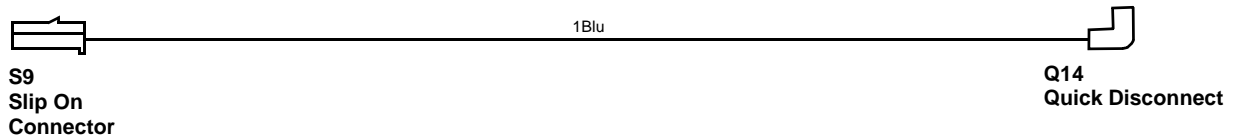

### W13 Wire Harness - Jackstand Switch Jumper



### W14 Wire Harness - Control Box Jumper (2 Req.)

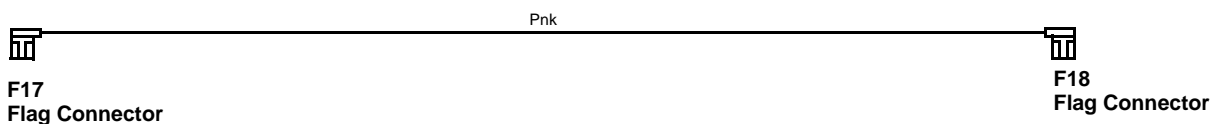

## **SNO-WAY PLOWS**

### **LIMITED ONE-YEAR WARRANTY**

SNO-WAY Warrants to the original retail purchaser for a period of one (1) year from the date of delivery from an authorized SNO-WAY Dealer that your new SNO-WAY Plow is free from defects in materials and workmanship if properly set up and operated in accordance with the recommendations set forth in SNO-WAY's Set-up and Operator's Manuals. This warranty does not cover normal wear items such as shoes and wearstrips.

SNO-WAY Plows used by a dealer as a demonstrator shall be warranted only for the period of one (1) year from the date of delivery to said dealer and the first subsequent purchaser shall be entitled to the remaining warranty protection.

This warranty shall not apply to any item of equipment which has been repaired or altered outside the SNO-WAY factory or authorized SNO-WAY dealership or which has been subject to misuse, negligence or accident: neither shall it apply to equipment which has not been operated in accordance with SNO-WAY printed instructions or has been operated beyond the SNO-WAY'S recommended snow plow operating class.

To validate this warranty, your dealer and you must complete the enclosed Warranty Registration Card at time of purchase of the plow and return the Factory copy to SNO-WAY International, Inc. within ten (10) days following delivery of your new Plow.

To obtain warranty service, promptly return your Plow or any defective part at your expense to any authorized SNO-WAY dealer during the warranty period. Replacement or repair of defective or inadequate parts shall be performed without charge for labor or materials by such dealer at his regular place of business during regular business hours after inspection and determination that the warranty applies.

#### **EXCLUSIONS OF WARRANTY**

Except as otherwise expressly stated herein, SNO-WAY makes no representation of warranty of any kind expressed or implied, including merchantability or fitness for particular purpose in respect to the equipment.

SNO-WAY shall not be liable for incidental or consequential damages for any breach of warranty, including but not limited to loss of use, inconvenience, rental or replacement equipment, loss of profits or other commercial loss.

No agent, employee or representative of SNO-WAY has any authority to bind SNO-WAY to any affirmation, representation or warranty concerning its equipment except as specifically set forth herein.

Certain limitations expressed herein are excludable in accordance with provisions of local law. Such limitations shall be deemed struck if such local law is applicable. All other limitations and provisions shall continue to apply.

**SNO-WAY INTERNATIONAL, INC.**

---

**SNO-WAY® INTERNATIONAL, INC.**



844 West State Street  
Hartford, WI 53027 USA  
Phone (262) 673-7200  
FAX (262) 673-7409  
©1999 Sno-Way® International