

# maxilift

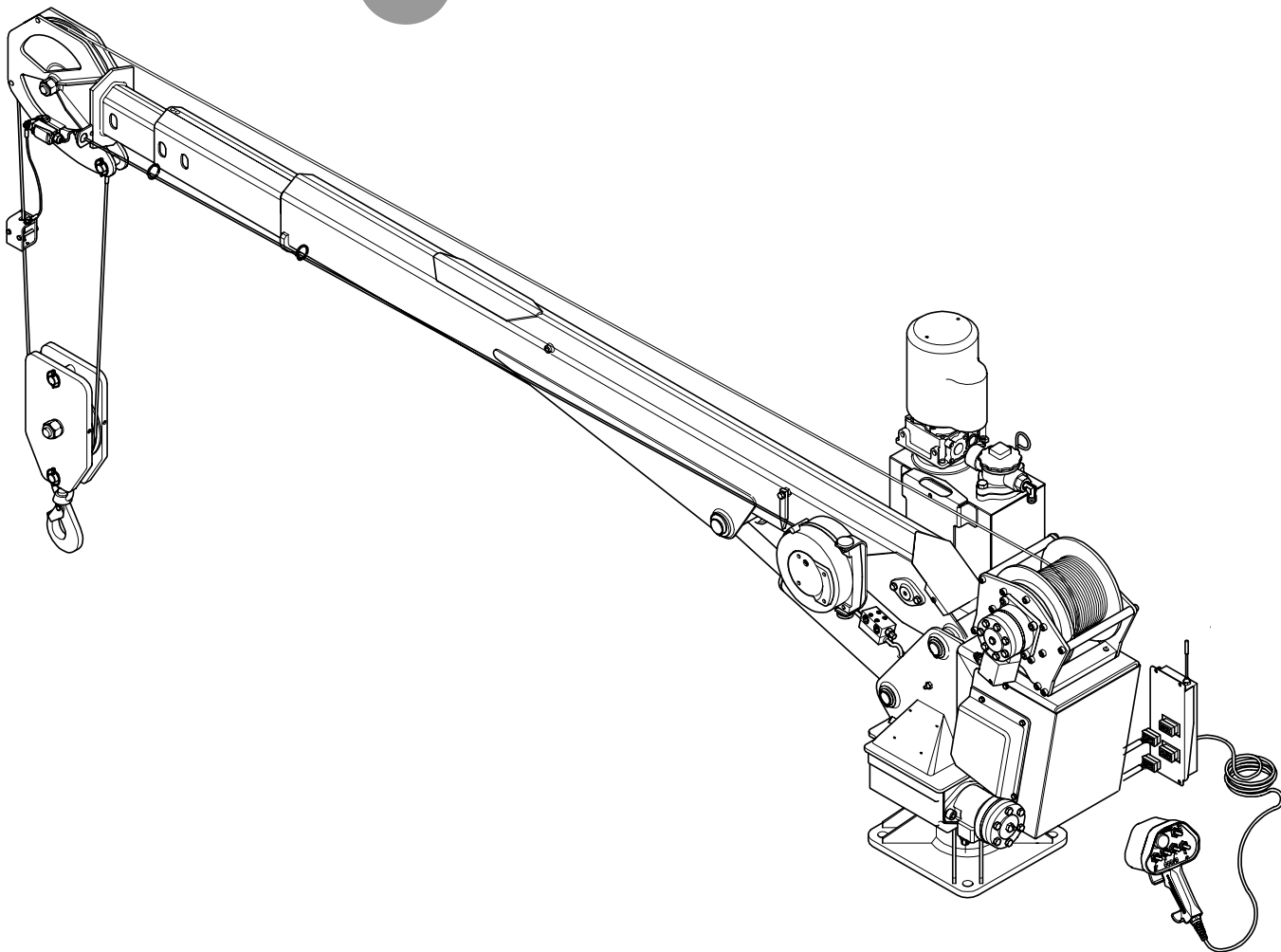

## ***SERVICE CRANE*** Mod. 4400

Code **MD.0.119**  
Rev **0**  
Edition **05/05**

***USE AND MAINTENANCE MANUAL***

OPTIONALS SUPPLIED ALONG WITH THE CRANE		
Description	YES	NO
Oil tank		
Outrigger beam - (mechanical jack)		
Outrigger beam - (hydraulic jack)		

The table has to be filled carefully with the above option when purchased

## PRELIMINARY INFORMATION

Operator's and maintenance manual of **MAXILIFT COBRA 4400 SERVICE CRANE**

Manual code: **MD.0.119**

This manual is valid starting from serial no: 9749

Manufacturer: **NEXT HYDRAULICS S.r.l.**

Via Mediterraneo 6, I 42022 BORETTO Reggio Emilia

In this booklet the word "**Manufacturer**" is referred to "**NEXT HYDRAULICS S.r.l.**"

List of documentation supplied along with the CRANE:

- Operator's and maintenance manual (for the end user)

SERIAL NO:.....

YEAR OF MANUFACTURING:.....

## **ATTENTION**

Always carefully read this manual before operating the crane. Most of the accidents occurred during operations are caused by the omission of elementary precautions and non fulfillment of the safety instructions. Many accidents can be avoided when their causes are well known and the relevant adequate counter measures are previously taken.

## INDEX

1	FOREWORD .....	PAGE	1
1.1	Summary .....	"	1
1.2	Remarks .....	"	1
1.3	Manual revision .....	"	2
2	HOW TO CONSULT THE MANUAL .....	"	2
2.1	Instructions .....	"	2
3	CRANE IDENTIFICATION .....	"	3
3.1	Versions and optional available .....	"	3
3.2	CRANE identification data .....	"	3
4	CRANE USAGE AND LIMITS OF APPLICATIONS .....	"	4
4.1	CRANE classification and proper usage .....	"	4
4.2	Improper usage .....	"	4
4.3	CRANE operator's training .....	"	4
5	SAFETY RULES .....	"	6
5.1	Rules concerning people .....	"	6
5.2	Rules concerning the crane .....	"	6
5.3	Rules for the correct positioning of the crane .....	"	7
5.3.1	Choice of the crane operating place pressure on the ground .....	"	7
5.3.2	Safety distance from trenches and slopes .....	"	7
5.3.3	Safety distance from electrical power lines .....	"	8
5.3.4	Crane and load ground connection .....	"	8
5.3.5	Influence of the wind on the crane operation .....	"	10
5.4	Rules concerning safety in the traffic .....	"	10
5.5	General rules on winch operations .....	"	11
5.5.1	Winch system operation .....	"	11
5.5.2	Operator safety tips .....	"	11
5.5.3	General rules when operating winch .....	"	11
5.6	WIRE ROPE .....	"	12
5.6.1	General .....	"	12
5.6.2	Wire rope precautions .....	"	12
6	DESCRIPTION OF THE CRANE .....	"	13
6.1	Model: 4400 H .....	"	13
6.2	Model: 4400 E - 12V/24V .....	"	14
6.3	Safety devices .....	"	15
6.3.1	Safety devices installed .....	"	15
6.3.2	Load limiting device .....	"	15
6.3.3	Relief valve .....	"	16
6.3.4	Pilot operated holding valves .....	"	16
6.3.5	Safety devices'sealing .....	"	16
6.4	Microprocessor remote control system .....	"	17
6.4.1	Electronic power unit .....	"	17
6.4.2	The radio receiving unit .....	"	18
6.5	The pendant button strip .....	"	18
6.5.1	The radio trasmitting button strip .....	"	19
6.6	Proportional mono-function regulation hydraulic unit .....	"	20
6.6.1	Proportional dual-mode regulation hydraulic unit .....	"	21
6.7	Wiring .....	"	21
6.7.1	Remote control use .....	"	22
6.7.2	Use of the mono-function proportional remote control .....	"	22
6.7.3	Use of the dual-mode proportional remote control .....	"	22

6.8	Display messages .....	Page	23
6.8.1	Normal display menu .....	"	23
6.8.2	Micro-switches and pressure switch display menu .....	"	25
6.8.3	Current display menu .....	"	25
6.8.4	Remote control button strip display meny .....	"	26
<b>7</b>	<b>OPERATING INSTRUCTIONS .....</b>	<b>"</b>	<b>27</b>
7.1	General attentions .....	"	27
7.2	Stabilizing the truck .....	"	28
7.3	Opening the crane .....	"	30
7.4	Closing the crane .....	"	30
7.5	Winch system operation .....	Page	30
7.6	Before starting traveling on road .....	"	30
7.7	Main errors occurring when operating the crane .....	"	30
7.8	Standard hand signals .....	"	31
<b>8</b>	<b>PUTTING THE CRANE INTO SERVICE .....</b>	<b>"</b>	<b>32</b>
8.1	Ten rules for the perfect crane operator .....	"	32
8.2	Daily check list .....	"	32
8.3	Safety tips for crane starting in cold climates .....	"	32
8.4	Crane protection and storage .....	"	32
8.4.1	Short shutdowns .....	"	32
8.4.2	Long shutdowns .....	"	33
<b>9</b>	<b>MAINTENANCE .....</b>	<b>"</b>	<b>34</b>
9.1	Warnings .....	"	34
9.2	Maintenance prescriptions .....	"	34
9.3	Maintenance schedule .....	"	35
9.3.1	Daily checking .....	"	35
9.3.2	Monthly checking .....	"	36
9.3.3	Checking every six months .....	"	36
9.3.4	Others .....	"	36
9.4	Crane servicing .....	"	37
9.4.1	Oil level checking .....	"	37
9.4.2	Oil change .....	"	37
9.4.3	Oil filter replacement .....	"	37
9.4.4	Wormgear assembly control .....	"	38
9.4.5	Greasing the hydraulic boom sections .....	"	38
9.4.6	Wear pads check and replacement .....	"	38
9.5	Greases and oils reference table .....	"	39
9.6	Wire rope .....	"	40
9.6.1	Wire rope inspection .....	"	40
9.6.2	Rope replacement .....	"	40
9.6.3	Wire rope lubrication .....	"	41
9.7	Possible faults and relevant remedies .....	"	42
<b>10</b>	<b>TECHNICAL DATA .....</b>	<b>"</b>	<b>44</b>
	Overall dimension .....		
	Performances .....		
	Load chart table .....		
<b>11</b>	<b>WIRING AND HYDRAULIC DIAGRAMS .....</b>	<b>"</b>	<b>46</b>
11.1	Pendant wiring .....	"	46
11.2	Power unit and control wiring .....	"	47
11.3	Hydraulic diagrams .....	"	48
11.3.1	Hydraulic diagram mono-function proportional .....	"	48
11.3.2	Hydraulic diagram dual-mode proportional .....	"	49

## 1 FOREWORD

### 1.1 SUMMARY

This manual is divided into chapters to make its consultation easier.

**Chapter 1:** Includes summary and a short introduction.

**Chapter 2:** Explains how to consult the manual.

**Chapter 3:** Crane identification data.

**Chapter 4:** Limits of crane operation and usage.

**Chapter 5:** Safety rules.

**Chapter 6:** Description of the crane, safety devices and controls.

**Chapter 7:** Description of operation and usage tips.

**Chapter 8:** Crane starting up and storage.

**Chapter 9:** Essential crane maintenance instructions. Additional instructions can be included in the truck maintenance manual.

**Chapter 10:** Includes the crane technical data, load charts and diagrams, list of main characteristics.

**Chapter 11:** Wiring and hydraulic diagrams

### 1.2 REMARKS

Many thanks for the preference kindly given to our product. Please remember that the servicing instructions and the load charts hereby reported and applied on the crane are an essential part of the crane supply itself. They are mainly intended for the crane operator and include all necessary information on the admittable and permissible field of usage for a safe operation. Anyway, these instructions are not a training manual for beginners or unskilled operators, it must be stressed that as a fundamental presupposition only skilled and professional crane operators are allowed to work with the crane.

The crane operator is directly responsible for the state of the crane and for every crane operation. When the training is hurried and full of gaps, this is the origin of many accidents. This manual gives the guidelines for a correct, safe usage of the crane and its rational maintenance. When daily and constantly applied, these guidelines ensure long service life with minimum maintenance costs, high performance of the crane and good commercial value after years. Moreover, most of the frequent accidents during operation and servicing are avoided. Once this manual has been read carefully, keep it in good conditions and quickly available close to the crane.

If a technical assistance is required please apply to the nearest authorized installer.

#### **ATTENTION**

As far as safety is concerned it is strongly recommended to carefully read the safety tips of the chapter, **SAFETY RULES**.

#### **ATTENTION**

Should some or any part of this manual be not clear, please contact the Manufacturer.

#### **IMPORTANT**

When receiving this manual, check if all the data are correct. Inform the Manufacturer if something is found wrong.

## **NOTE**

The table on the back of the front page has to be filled at customer's care. It contains all the necessary data required when calling our Technical Service.

A copy of this manual is supplied along with every crane. Data, descriptions and pictures of this manual are not binding. The Manufacturer reserves the right to change at any time all the items, components and parts deemed to be necessary for product improvement or commercial or production needs. This right is kept without obligation of quick updating of this manual. Fundamental data, performances and characteristics of the product will be maintained.

### **1.3 MANUAL REVISION**

Should be necessary to carry some modification on the crane, they must be authorized by the Manufacturer which also takes the commitment of manual updating. Revised or added pages will be mailed to the Customer and shall be inserted in the manual at his care and cost.

## **2 HOW TO CONSULT THE MANUAL**

### **2.1 INSTRUCTIONS**

Always carefully read this manual before operating the crane. In this manual the following symbols are used:



Referred to dangers related to the described activity, when the safety of people is concerned.



Referred to dangers related to the described activity, mainly when the safety of things is concerned (for instance, damage of the load or of the crane).



Referred to information or integration on crane operation.

## **NOTE**

Used to draw your attention on information or suggestions to make easier the crane usage for the operator.

The symbols and marks are completed with notices stating the dangers, their nature, the avoidance actions to be taken and tips to be followed.



In this manual the crane is shown in many pictures with its panels or covers removed for a better evidence. It is forbidden to use and operate the crane with panels, covers and other safety devices removed.

### 3 CRANE IDENTIFICATION

#### 3.1 VERSIONS AND OPTIONS AVAILABLE

The service instructions written on this manual are referred to the **CRANE MAXILIFT COBRA 4400**. This model is supplied in 6 versions. When ordering, one or more of the following versions are to be specified:

Version	Remote control	Hydraulic supply	Power supply
<b>4400 XP - H</b>	Cable - Proportional mono-function	Fed by a pump, driven by a P.T.O. truck	12 - 24V
<b>4400 XP - E</b>	Cable - Proportional mono-function	Fed by a DC electro-hydr. power pack	12 - 24V
<b>4400 XPD - H</b>	Cable - Proportional dual-mode	Fed by a pump, driven by a P.T.O. truck	12 - 24V
<b>4400 RXP - H</b>	Radio - Proportional mono-function	Fed by a pump, driven by a P.T.O. truck	12 - 24V
<b>4400 RXP - E</b>	Radio - Proportional mono-function	Fed by a DC electro-hydr. power pack	12 - 24V
<b>4400 RXP - H</b>	Radio - Proportional dual-mode	Fed by a pump, driven by a P.T.O. truck	12 - 24V

The following options are available for the above versions:

Type of optional	Available on models
Oil tank	(only for H version)
Outrigger beam - (mechanical Jack)	All
Outrigger beam - (hydraulic jach)	All

#### 3.2 CRANE IDENTIFICATION DATA

Every crane is identified by its serial number and name of the model written on the plate riveted on the crane.

##### Data plate description

- a) Crane model
- b) Serial number
- c) Year of manufacturing
- d) Lifting class
- e) max SWL
- f) Approval number



**ATTENTION**

It is strictly forbidden to change, erase, modify the data written on the plate.

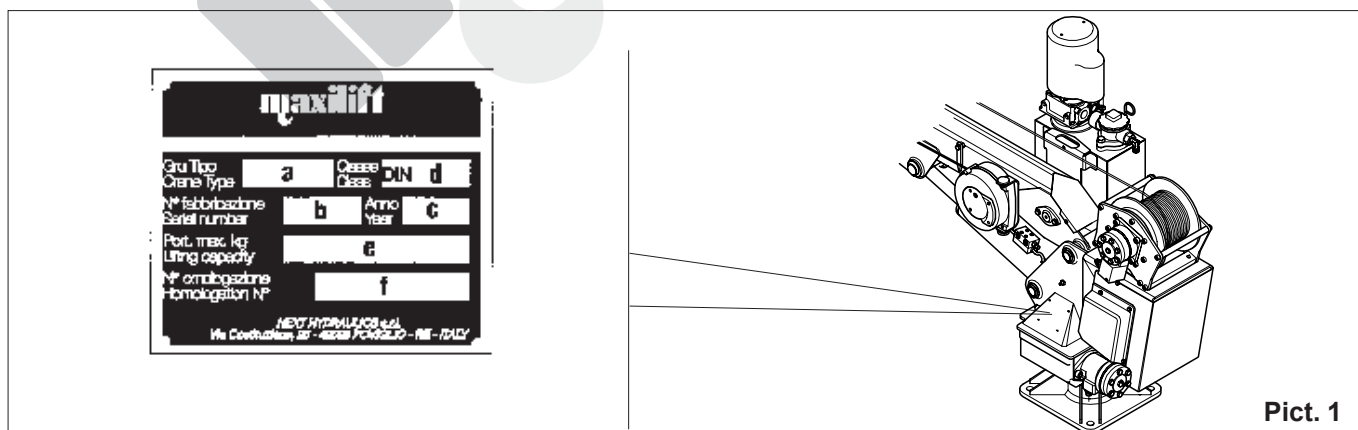

Pict. 1

## 4 CRANE USAGE AND LIMITS OF APPLICATIONS

### 4.1 CRANE CLASSIFICATION AND PROPER USAGE

The machine is an hydraulic truck crane for hook service. It can also be used for the same purpose from a static mounting. The lifting capacity is 2.2 ton-meter (16,000 ft. lbs.), making it especially suitable for installation on light truck.

The crane is classified in class H2-B3 according to DIN 15018 standards, and must be used accordingly, that is: trucks loading/unloading, hook service.

### 4.2 IMPROPER USAGE

It is forbidden:

- To use the crane in different operations from those it has been designed and built for. (see above point 4.1).
- To use the crane with attachment like: grabs, clamshells, magnets and so on.
- Pulling loads with crane in horizontal position.
- To operate the crane with procedures different from those described in this manual, or using components and attachments not approved when the crane was designed.
- Non observance of the established maintenance programs.
- Non observance of safety rules.
- To make modifications involving crane components or parameters related to the working cycle.
- The unauthorized use of captive spare parts and components not specifically approved by the Manufacturer.
- To carry out modifications or structural interventions without the approval of the Manufacturer.
- To operate the crane out of the admissible range of temperatures:  $-30^{\circ}\text{C} / +50^{\circ}\text{C}$  ( $-22^{\circ}\text{F} / +122^{\circ}\text{F}$ ).

Any of the above mentioned improper usages or non observance will cause:

- immediate cancellation of the Manufacturer Warranty
- cancellation of Manufacturer liability for damage of people, animals, things.

### **ATTENTION**

**The improper usage can damage the crane and subsequently result in dangerous situations for the staff entitled to its operation.**

### 4.3 CRANE OPERATOR'S TRAINING

The crane must be operated only by skilled people trained for this purpose.

This people will be asked for:

- a basic technical education and a working experience in the mechanical, hydraulic and electrical field;
- a technical knowledge of cranes operation, covering all the points, especially the load charts and the truck stability against tipping over;
- practical knowledge of slings usage and precautions when moving the loads;
- complete knowledge of all the operations and motions to be executed with the crane; competent and qualified personnel of the authorized workshop which has installed the crane will take care of this;
- complete reading and understanding of this manual;
- complete knowledge and understanding of safety and risk avoidance regulations;
- Vision of at least 20/30 Snellen in one eye and 20/50 in the other, with or without the aid of corrective lenses;

- normal depth perception and field of vision (peripheral);
- ability to distinguish colors if color recognition or differentiation is, required for safe operation;
- adequate hearing, with or without a hearing aid;
- sufficient strength, endurance, agility and coordination to meet equipment operation demands;
- emotionally stable;
- not subject to seizures, loss of physical control, dizziness or have physical limitations which could impair the ability to safely operate the crane.



## 5 SAFETY RULES

### 5.1 RULES CONCERNING PEOPLE

- Always wear the prescribed personal safety devices
- Always wear approved accident-prevention clothing such as: protective helmets, anti-slip shoes, protective gloves, antinoise headphones, protective glasses, reflective jackets with breathing apparatus. Consult your employer regarding current safety regulations and accident-prevention equipment.
- Do not wear ring, wristwatches, jewelry, loose-fitting or hanging clothing such as ties, torn garments, scarves, unbuttoned jackets or unzipped overalls, which could get caught up in the moving parts of the crane.
- Keep quickly and readily available on the truck a first-aid box and a fire extinguisher. The fire extinguisher must always be kept charged and has to be used according to current regulations.

### 5.2 RULES CONCERNING THE CRANE

- The Manufacturer is not liable for accidents occurred during the usage of the crane caused by non fulfillment from the operator's side of current rules, laws and regulations.
- The crane is designed to be used within the  $-30^{\circ}/+50^{\circ}$  ( $-22^{\circ}\text{F}/+122^{\circ}\text{F}$ ) temperature range and has to be operated only in this range. The manufacturer is not liable for accidents occurred during the usage of the crane outside this temperature range.
- Carefully read the Operator's and maintenance manual before starting up, using, servicing or doing any thing on the crane.
- Read and follow all the safety instruction plates applied on the crane before starting up, using, servicing or doing anything on the crane.
- Do not use controls and hoses as handholds: these parts move and cannot provide stable support. Furthermore, a control mistakenly moving can accidentally set the crane in motion.
- The operator's control desk must always be kept clean from oil, grease, mud, snow to avoid accidents due to slippery surface.
- The safety instruction plates, notices, load charts and any other sticker applied on The crane must be kept readable and in good conditions. If necessary, replace them. The position of these plates is shown in the following picture.

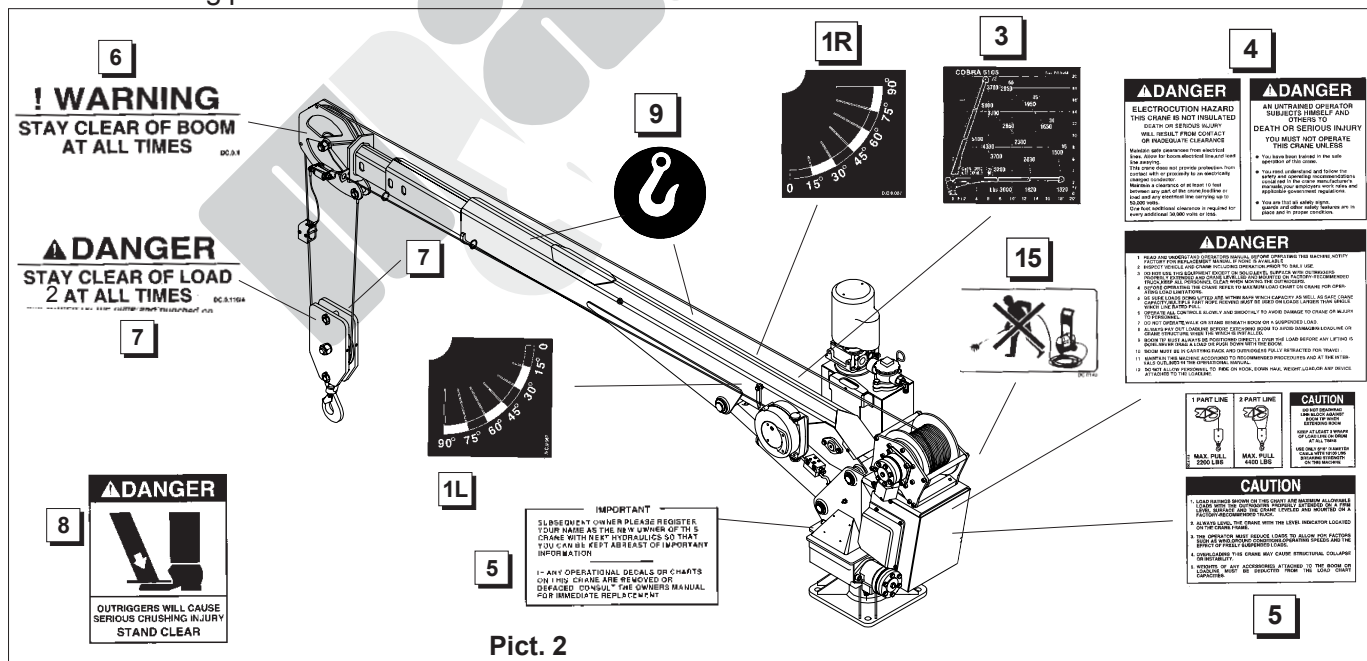

## 5.3 RULES FOR THE CORRECT POSITIONING OF THE CRANE

### 5.3.1 Choice of crane operating place pressure on the ground

- Carefully choose the place where lowering and put into action the stabilizers of the crane outriggers. The most important thing is the capacity of the ground to bear the pressure produced by the outriggers.
- Make sure that the outriggers working area is free from underground piping, tunnels, holes.
- The positioning must be carried out so as to operate the crane with the shortest outreach possible and without any obstacle in the working area.
- Never move the crane from its rest position without stabilizing the truck.
- The outriggers reaction is transmitted to the ground by steel pads. When this pressure exceed the maximum admissible pressure value of the ground, the surface of their bearing area must be increased by means of additional plates of firm material (i.e. wooden plates). The outriggers pads must work in the middle of the additional plates. The required bearing surface can be easily calculated as follows when the outrigger's reaction and the admissible pressure on the ground are known. Outrigger's reaction: look at the plate applied on the outrigger jack. Admissible pressure on various types of soils: look at the following table for indicative values.

#### Bearing pressure calculation

When:

**t** = outrigger's reaction (tons) (US ton)

**A** = bearing plate surface (cm<sup>2</sup>) (sq. in.)

Then:

**p** = bearing pressure on ground (daN/cm<sup>2</sup>) (lbs./Sq.in.)

$$p = (1000 \cdot t) : A \text{ (metric)}$$

$$p = (2000 \cdot t) : A \text{ (U.S.A.)}$$



**In case of doubts on the ground carrying capacity, make a hardness test of the ground.**

Always level the crane acting on outriggers with reference to the level indicator fitted on the truck. Maximum admissible angle is 3°.

### 5.3.2 Safety distance from trencher and slopes

The crane must be positioned sufficiently far away from trenches or slopes. The safety distance depends also on the soil, if the slopes or trenches are not sustained. Rule of the thumb: (look at the following picture)

SOIL	ADMISSIBLE PRESSURE	
	(daN/cm <sup>2</sup> )	(lbs./sq.in.)
Dumped, non compacted soil	0.0/1.0	0.0/14
natural, virgin soil:		
-mud, marshland, peat	0.0	0,0
incoherent artificially compacted soils:		
-fine and medium size sand	1.5	21
-large size sand, gravel	2.0	28
natural coherent terrain:		
-doughy	0.0	0,0
-soft.	0.4	6
-stiff	1.0	14
-demi-solid	2.0	28
-solid	4.0	56
rock, not altered by atmospheric agents, well stratified and slightly cracked:		
-closed stratified	15.0	213
-solid stratified, pillar-like	30.0	426

- for brought-back or crumbling terrain safety distance (a) must be double of the slopes' depth that is:  
 $a = 2 \cdot b$
- for compacted, not crumbling terrain safety distance (a) must be equal to the slopes' depth, that is:  
 $a = 1 \cdot b$

Distance to be measured from point ©

Max. reaction on the ground varies according to the vehicle where the crane is installed.

## **IMPORTANT**

The installer must calculate this max. reaction on the ground and applied the value on the outrigger jacks.

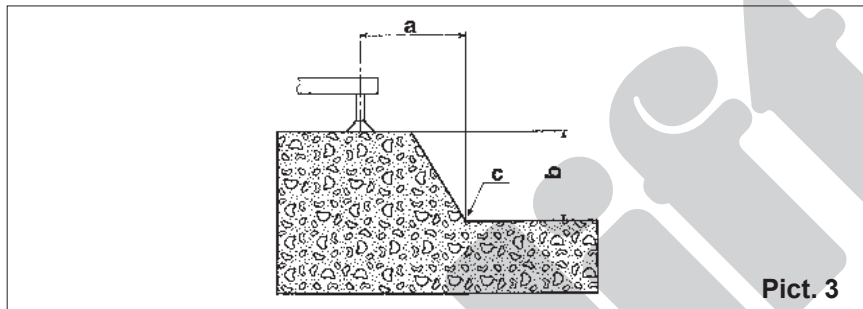

### 5.3.3 Safety distance from electrical power lines

Always keep a sufficient safety distance when you cannot avoid having electric power lines in the working area of the crane. Special care must be taken when the power lines have not been disconnected by experienced people, or when the lines status is unknown.

Voltage (V)	minimum distance	
	(m)	(ft)
up to 1000 v	1	4
from 1 kV to 110 kV	3	10
from 110 kV to 220 kV	4	13
from 220 kV to 380 kV	5	16

## **DANGER**

Always keep a sufficient safety distance from electric power lines. Follow present law regulations. When the voltage of the lines is unknown keep a minimum safety distance of at least 5m (20 ft.)

### 5.3.4 Crane and load ground connection

The crane can be electrostatically charged, especially when the additional bearing plates are made of insulating materials (wood, plastics) It has to be noted that, even when the crane has been connected to ground, the load can be loaded electrostatically charged, because the rope pulleys or the slings and ropes used to lift the load are made of insulating materials.

## **DANGER**

Always connect to ground both the crane and its load before starting operations

Grounding is **especially** required when:

- working close to electric power lines;
- working nearby powerful broadcasting plants such as radio, T.V., and so on
- working nearby electricity plants where high frequency is involved
- when a storm is approaching

## Crane ground connection



**electrocution hazard**

**While grounding the crane, carefully follow the below mentioned instructions, in order to avoid electrocution hazard**

In order to avoid electrocution hazard the following tips must be followed:

- drive a metal rod, roughly 1.5 meter long, (5 ft.) in the ground, at least 1 meter (4 ft.) deep
- connect a power cable of minimum 16 mm<sup>2</sup> (0,025 sq. in.) cross section to the former rod. This linkage must be made with a hose clamp or a vice.
- moisten the ground all around the rod to improve conductivity.

### **NOTE**

**Arrange the linkage for ground connection and the relevant symbol**

- connect the remaining end of the cable with the point of connection indicated on the crane base.



**electrocution hazard**

**The ground cable must be connected only on the indicated point on the crane base. Avoid any linkage to screwed on parts of the crane, such as valves, cover plates, gearboxes, etc.**



**electrocution hazard**

**Always ground the crane perfectly.**

## Load ground connection

In order to avoid the electrostatic charging of the load it is necessary to use:

- a metal rod having a good conductivity, with a length of 1.5 meters (5 ft.) roughly, to be driven into the ground, at least 1 meter (4 ft.) deep.
- a power cable with a minimum cross section of 16 mm<sup>2</sup> (0,025 sq. in.).
- a second metal rod, having good conductivity and an insulating handle complying to the relevant safety Regulations. This rod has to be used to touch the load.
- Then connect this cable to the ground rod on one side. Moisten the ground all around the rod to improve conductivity.
- Then connect the other side of the cable to the insulated rod. Both connections must be made using the relevant vices or metal clamps as an alternative.

**⚠ DANGER**  
electrocution hazard

**Always connect in a perfect way the load and the ground**

Before touching the load with your hands, always ground the load by touching it with the insulated rod.

**⚠ DANGER**  
electrocution hazard

**Always hold the rod by its insulated handle.**

### 5.3.5 Influence of the wind on the crane operation

A strong wind can overload the crane, so during operations keep under control the wind speed. When working with full load, the maximum admissible wind speed is 45 km/h (28 mile/h).

When this value is exceeded, any crane operation must be stopped and the crane must be brought to the rest position. Since the maximum working height of the crane is reasonable, refer to the following table to evaluate the possible wind effect:

Force of the wind			wind speed		wind effects
Beaufort	Denom.	m/sec(ft./sec.)	km/h	(mile/h)	
0 calm	0 - 0.2	0-0.65	1	0.6	calm, the smoke goes straight upwards
1 light	0.3 - 1.5	1-5	1-5	0.6-3	wind direction can only be seen looking at the smoke. Wind indicators are idle
2 light	1.6 - 3.3	5-11	6-11	3-7	leaves are moving, the wind can be on the face.
3 light	3.4 - 5.4	11-18	12-19	7-12	leaves and small branches are moving breeze
4 slow	5.5 - 7.9	18-26	20-28	12-17	dust and paper sheets are lifted up, breeze slender, rods are moved
5 strong	8 - 10.7	26-35	29-38	17-24	small waves on water surfaces breeze
6 strong	10.8 - 13.8	35-45	39-49	24-30	rods are bent, it is difficult to use wind umbrella
7 tight	13.9 - 17.1	45-56	50-61	30-38	the trees are moved it is difficult to wind walk against wind
8 stormy	17.2 - 20.7	56-68	62 - 74	38-46	trees' branches break. it is very difficult to walk in open areas
9 tempest	20.8 - 24.4	68-80	75 - 88	46-55	small damages to buildings (roofing tiles wind fall down)
10 violent	24.5 - 28.4	80-93	89 - 102	55-63	big damages to the buildings, trees uprooted tempest

### 5.4 RULES CONCERNING SAFETY IN THE TRAFFIC

- The machine is an hydraulic crane for lorries and light trucks. The installation on the vehicle must be made in compliance with the relevant national laws and regulations.
- When traveling on roads and public sites always respect the relevant national laws and regulations.

**⚠ DANGER**

**Before traveling on roads, make sure that the crane is folded in rest position. If the crane is open or lying on vehicle's body exceeding the overall dimensions allowed by the highway code, it can hit bridges, electric power lines or other obstructions.**

- Before driving away, make sure that the lever of the pin securing the outrigger's beam is fully locked. Accidental slipping out of the outrigger during traveling can result in serious damages. Special care must be taken when driving nearby crossroads, lever-crossing and subways.

## 5.5 GENERAL RULES ON WINCH OPERATIONS

### 5.5.1 Winch system operation

The Winch is mounted at the rear of the first section boom. It has capacities totally independent of the rest of the crane and can normally pull more than the crane itself can withstand. Therefore, care must be taken to insure that the load being lifted is within boom rating. To lift some of the heavier loads on the capacity chart, it will be necessary to multiple-part reeve the winch block to increase the lifting capacity of the winch (the speed is proportionately slower) and remain in the strength limitations of the winch and wire rope.

The winch load rating chart on each machine provides the information for pull limitations on the winch with various applicable part reevings. These ratings are based on providing the proper operating safety factor on the wire rope supplied with the machine.

Therefore, any replacement rope must meet the rope specifications for size, construction and strength as outlined in specification sections of this manual.

### 5.5.2 Operator safety tips

- Do not pull the load block into the boom tip.
- Payout loadline before or during boom extension to avoid two-blocking.
- Do not allow personnel to ride the load-line, hook or load, or any other device attached to loadline.
- Keep at least three full wraps of wire rope on the winch drum at all times.
- Check the winch brake for proper operation before handling the load.
- Use proper multi-part reeving for the load to be lifted.
- When using multi-part reeving, be sure cable is properly routed.
- Know the lifting capacity of both the winch and boom. They will have different capacities. The weight of the load must not exceed the lesser capacity.
- Do not drag loads with winch or boom.
- Always wind loadline under tension to assist proper spooling

### 5.5.3 General rules when operating winch

- 1 - Always operate the winch control to payout the loadline while extending the boom. This will maintain clearance between the boom tip and loading hook.
- 2 - Do not pull load block into boom tip.
- 3 - Make certain the winch cable is not twisted or kinked and that cable is properly seated on the drum and in the sheaves.
- 4 - Before lifting a load, always make certain that three full wraps of rope will remain on the drum at all times throughout the lift.
- 5 - When lifting a load approaching the rated winch load, raise the load a few inches and return the control to neutral to determine if the brake is working properly.
- 6 - Do not drag loads in any direction with the winch.
- 7 - Never attempt to lift loads which are not loose and free, i.e. frozen down material or poles out of ground.
- 8 - Maintain tension on the loadline at all times to prevent the cable from becoming twisted or improperly seated on the winch drum or sheaves.
- 9 - Avoid rough boom lifting and lowering manoeuvres with suspended load, in order not to cause dangerous swingings of the same.
- 10- Avoid boom extension manoeuvre under load. When moving loads near to max. rates it is rather advisable to extend the boom without load in order to reach the vertical line of the same, and then to proceed with lifting by using the winch.

## 5.6 WIRE ROPE

### 5.6.1 General

Wire rope can be the weak link in crane safety. It is subjected to heavy loads, abrasion, kinking, extreme weather conditions, chemical attack and other forces which can reduce its reliability. The inspection and care of wire rope is essential in the effort to provide for safe working conditions.

### 5.6.2 Wire rope precautions

- 1 - Avoid the formation of kinks. Kinks will cause severe weakness in the rope. No corrections are available for kinked rope.
- 2 - Do not drag wire rope over a non-rotating support such as a non-functioning sheave. Severe abrasion caused to outer wire strands will result from friction.
- 3 - Do not use worn sheaves or flat grooved sheaves. They do not provide support to the full radius of the rope. Flattening and distortion will result.
- 4 - Do not use nicked or otherwise broken sheaves. Necks and cracks in sheaves will cut the wire rope.
- 5 - Evenly wrap wire rope onto the drum. Unevenness will cause crushing and/or crimping of the rope.
- 6 - Select replacement wire rope to match the capacity and use of the crane. The crane was originally equipped with appropriate wire rope.
- 7 - Do not expose the rope to corrosive chemicals.
- 8 - Lubricate the rope frequently to reduce friction and help prevent corrosion.

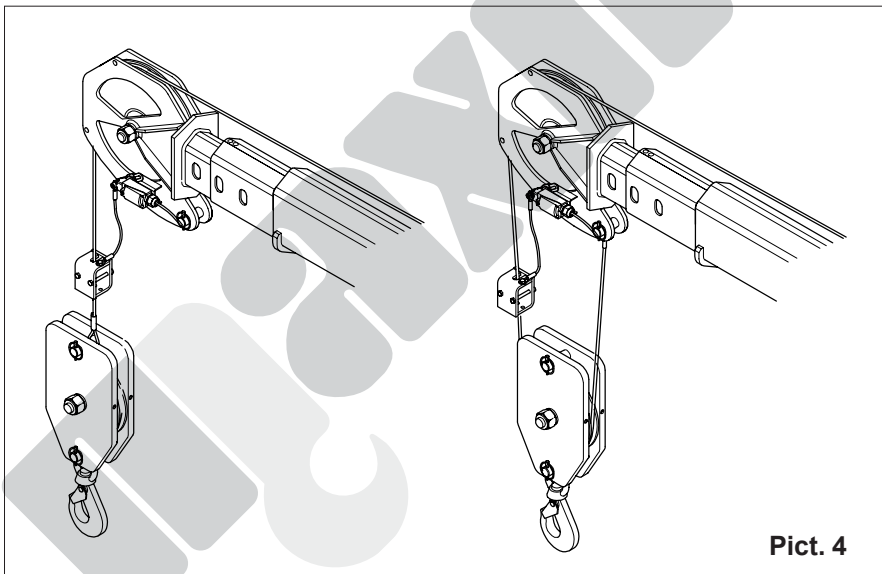

## 6 DESCRIPTION OF THE CRANE

### 6.1 MODEL 4400 H

Item Description

- 1 Slewing system
- 2 Slewing motor
- 3 Column
- 4 Main boom
- 5 Boom hoist cylinder
- 6 First hydraulic boom section
- 7 Second mechanical boom section
- 8 Telescope cylinder
- 9
- 10 Hydraulic unit
- 11 Electronic Power unit
- 12 Cable or radio remote control box
- 13 Winch
- 14 Travelling block
- 15 Oil tank - (only for H version ) OPTIONAL
- 16 Outrigger beam - (mechanical jack) OPTIONAL
- 17 Outrigger beam - (hydraulic jack) OPTIONAL

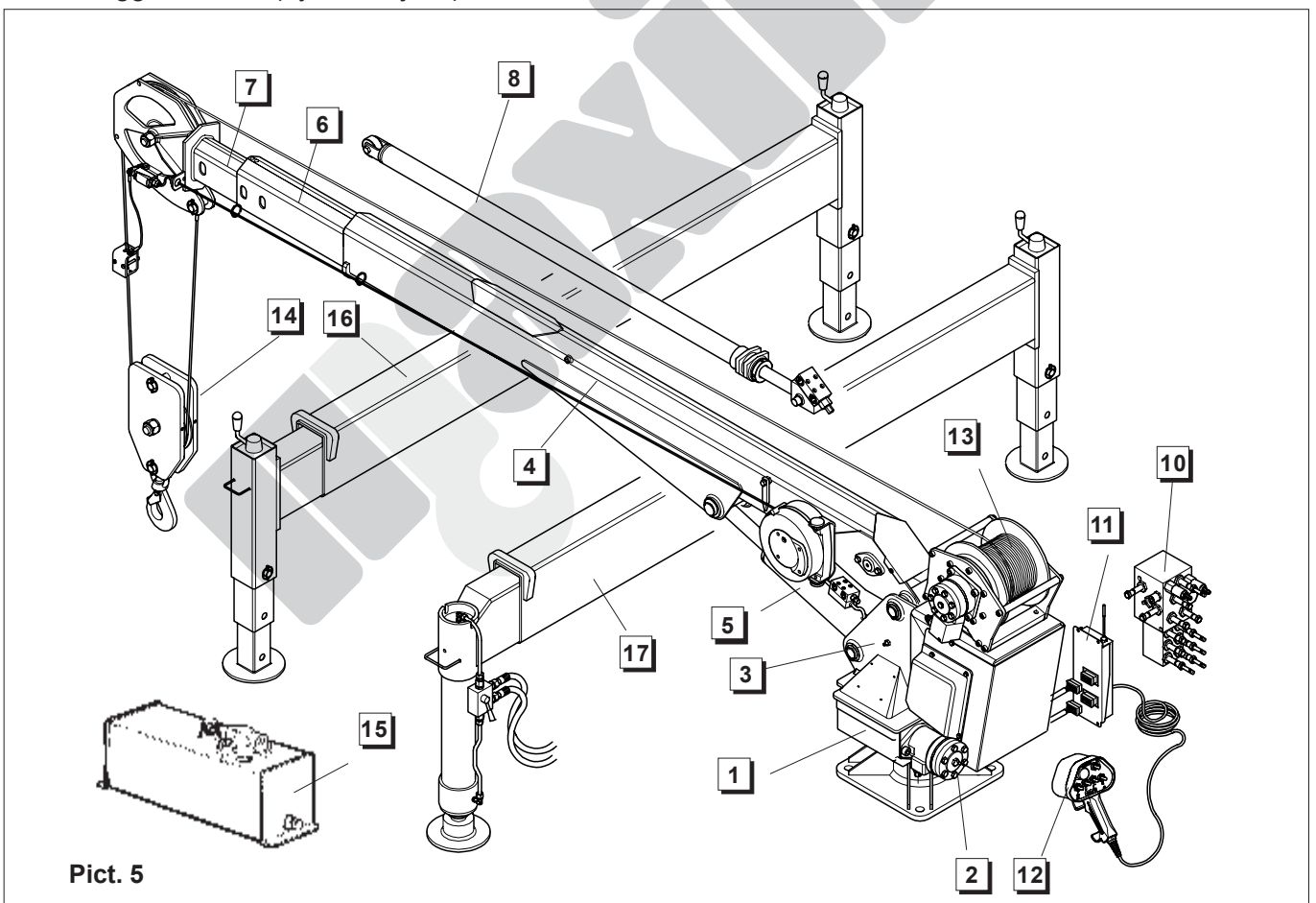

## 6.2 Model 4400 E 12V/24V

Item Description

- 1 Slewing system
- 2 Slewing motor
- 3 Column
- 4 Main boom
- 5 Boom hoist cylinder
- 6 First hydraulic boom section
- 7 Second mechanical boom section
- 8 Telescope cylinder
- 9
- 10 Hydraulic unit
- 11 Electronic Power unit
- 12 Cable or radio remote control box
- 13 Winch
- 14 Travelling block
- 15 Electro-hydraulic power pack
- 16 Outrigger beam (mechanical jack) OPTIONAL
- 17 Outrigger beam (hydraulic jack) OPTIONAL

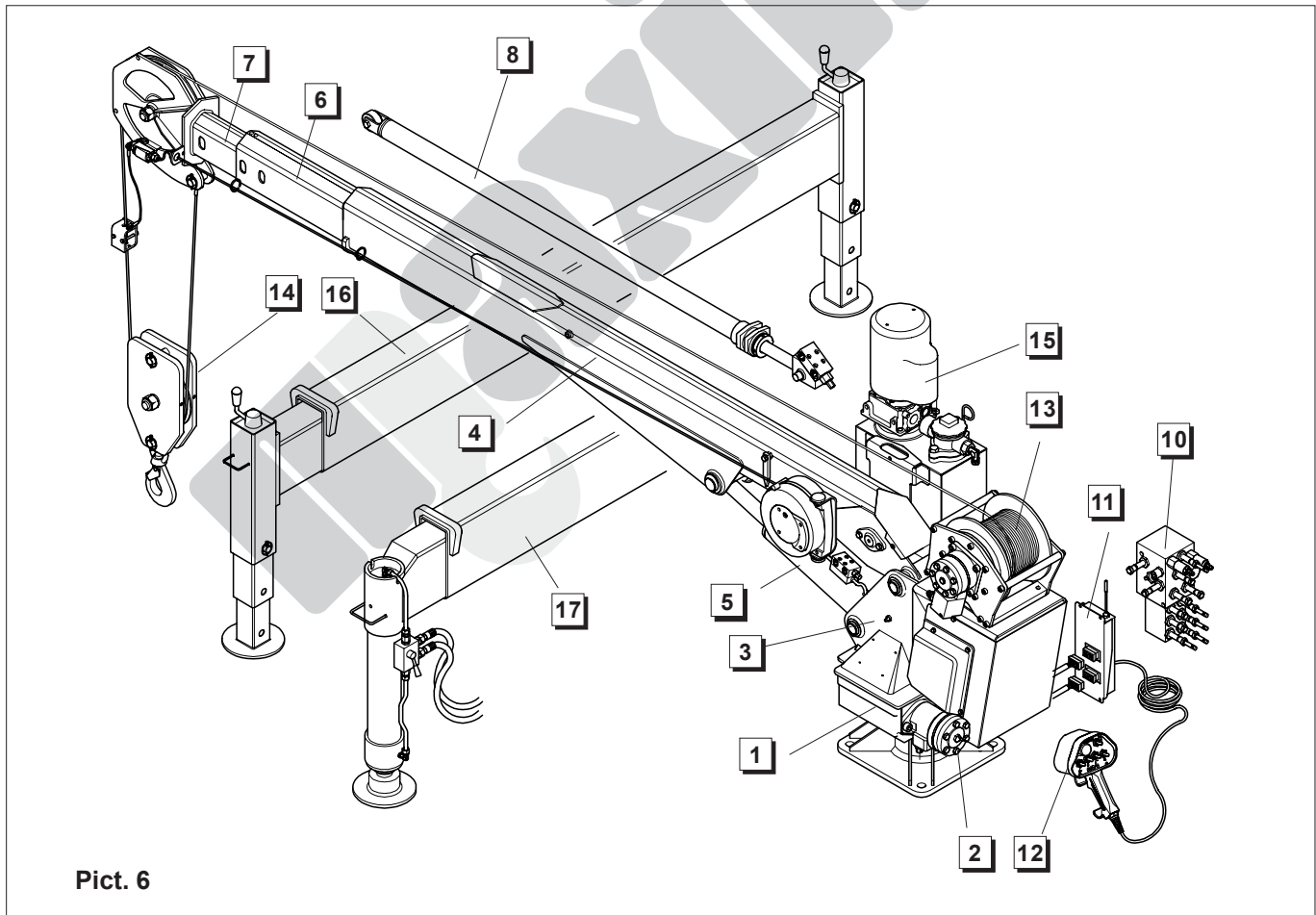

## 6.3 SAFETY DEVICES

### 6.3.1 Safety devices installed

All the safety devices, installed on MAXILIFT **COBRA 4400** crane, are listed and described in the following pages.

#### description of safety functions

The crane is fitted with 4 standard electro-hydraulic safety limitations:

- 1) The load limiting device, which intervenes each time the load mentioned on loading diagram is exceeded and locks the crane, stopping all movements, except re-entry of boom extension and lowering the load.
- 2) 0° working placing of the boom. The crane is fitted with a stop-end system allowing only boom lifting manoeuvre when the position is lower than 0° (rest position)
- 3) Stop-end system for winch raising, which intervenes in order to avoid the travelling block to hit against the pulley. It stops the raising of the winch rope, boom lowering and boom extension.
- 4) Stop-end system for winch lowering, which intervenes when in the winch drum remaining only 3 wraps of rope and locks the lowering of the winch rope.



**It is strictly forbidden to alter or manipulate the safety devices**

Before operating the crane make sure that all the safety devices are in perfect working conditions

### 6.3.2 Load limiting device

The load limiting device system locks crane functioning when pressure in the main cylinder reaches the setting level, corresponding to the nominal crane moment.

The load limiting is used in order to avoid crane overload.

In lock position it is not possible to carry out any manoeuvre, except re-entry of boom extension and lowering the load (only possible manoeuvres).

In order to unlock the crane, re-entry with the boom extension until crane moment becomes lower than that marked on the loading diagram, or intervenes on winch lowering by putting the load on the ground.



**The load limiting device, even when in perfect working condition, cannot avoid accidents due to operator's maneuvering mistakes.**



**It is strictly forbidden to operate the crane with its load limiting device switched off or put out of service or faulty.**

#### NOTE

**The load limiting device can lock at the max. main boom angle even without load.**

**In such case, in order to unlock the machine it is necessary to act simultaneously both on the extension re-entry and boom lowering levers.**

### 6.3.3 Relief valve

The main relief valve is on the control valve and limits the maximum working pressure.

### 6.3.4 Pilot operated holding valves

These valves are installed on every cylinder and will stop and lock every motion of the cylinder should any pressure loss occur. Before starting operations it is necessary to check that these valves are perfectly working, as follows:

- lift a load and raise the boom up to an angle of 45° upwards, with the boom sections partially extended
- switch the truck engine off push and pull repeatedly all the control switches: the load must remain still.

### 6.3.5 Safety devices' sealing

Some safety devices or crane components can be sealed after setting during testing operations. Such sealing can be only removed by the manufacturer or by an authorized workshop who will carry out a new sealing after repairing according to Manufacturer's specifications.



**The removal of sealing by non authorized personnel, or a sealing not complying to manufacturer specifications results in an improper usage of the crane.**

## 6.4 MICROPROCESSOR REMOTE CONTROL SYSTEM

The **COBRA** cranes are equipped with an advanced control and safety devices managing system, with microprocessor logic, allowing a correct crane functioning and safety devices managing, but also supplying to the operator, when necessary, some indications helping him for a quick diagnosis of a working problem, or an adjustment to carry out.

### AVAILABLE CONTROL VERSIONS

- Proportional mono-function cable control
- Proportional dual-mode cable control
- Proportional mono-function radio control
- Proportional dual-mode radio control

The system is consisting of the following main components (Pict. 7):

- 1) Control and safety devices managing control unit
- 2) Remote control button strip
- 3) Directional and flow regulating hydraulic unit
- 4) Solenoid valves wiring
- 5) Wiring for stop end and pressure switch connection and power supply.

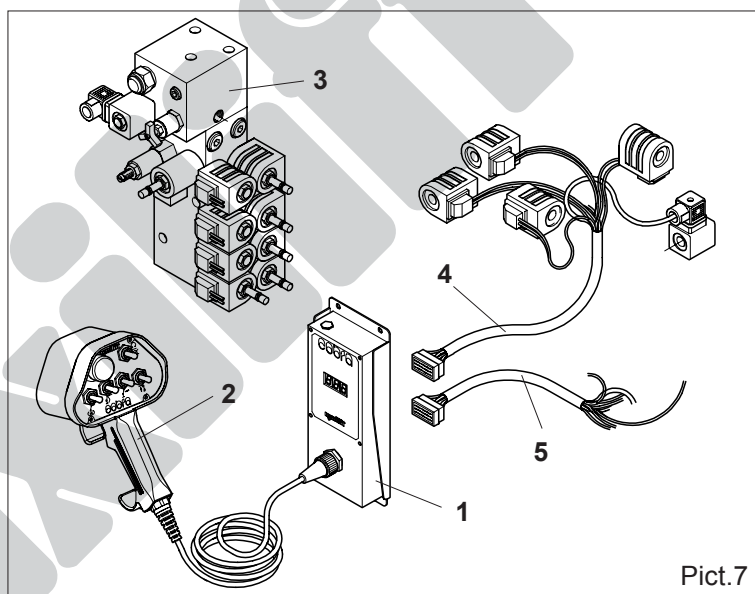

Pict.7

### 6.4.1 ELECTRONIC POWER UNIT (Pict.8)

The electronic control unit, placed beside column casing, consists of a tight stainless steel box holding the circuit board with microprocessor logic for the management of the remote control and the safety systems required for crane functioning.

On the control unit front side there is a three-digits red display (1) to be used as an interface to the operator for checking or adjusting operations.

The connector (2) for the remote control button strip is placed on the control unit.

The connector is equipped with a protection cover, to be applied when the crane is not operating.

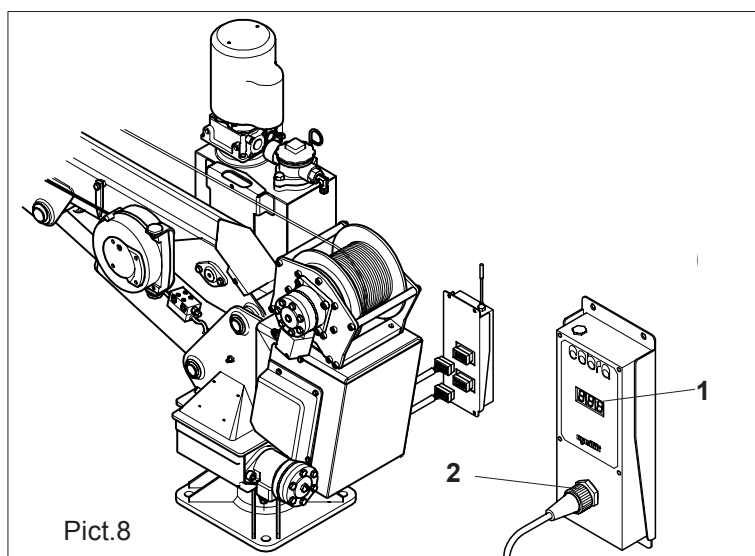

Pict.8

## 6.4.2 THE RADIO RECEIVING UNIT (Pict.10)

In case of radio remote control, the control unit **(3)** holds the radio module, and accomplishes the function of receiver, besides managing the complete machine logic, and it is equipped with an antenna on its upper part.

In this case, the connector is used to supply the batteries of radio remote control button strip **(4)** through the cable on issue **(1)**. This cable can be also used to work with the transmitter cutting out the radio link, as required by the law in some working environments (airports, hospitals, etc.).

Moreover, the use of the serial cable allows normal working in case of noise.

The antenna, even if not essential, improves the reception in the intermediate/long-range.

## 6.5 THE PENDANT BUTTON STRIP (Pict.9)

The pendant for single-hand use was designed to give the operator an ergonomic, practical remote control device, and to optimize the several crane functions.

It is essentially consisting of a plastic container with protected control panel completely connected to an ergonomic handgrip.

On the panel are located the crane operating selectors **(S)** in radial arrangement.

Above the selectors there is the emergency button **(P)** with safety stop function.

The emergency button (P) must be used also to switch on and off the remote control pendant.

Beside the emergency button there is the engine start-stop selector, when these two functions are activated. The system provides the possibility of supplying and controlling these two functions, which are external to the crane.

The pendant panel is fitted with an essential symbology for the different functions on a green background, which is very agreeable and intuitive for the operator.

In the lower and protected part of the handgrip is located the trigger button. By acting in a gradual way on this button it is possible to meter the movement speed, which is to be pre-selected by the manoeuvre selectors placed on the upper panel.

On the cable end, which can keep its flexibility and handling even under extreme conditions, is applied the connector to the control unit.

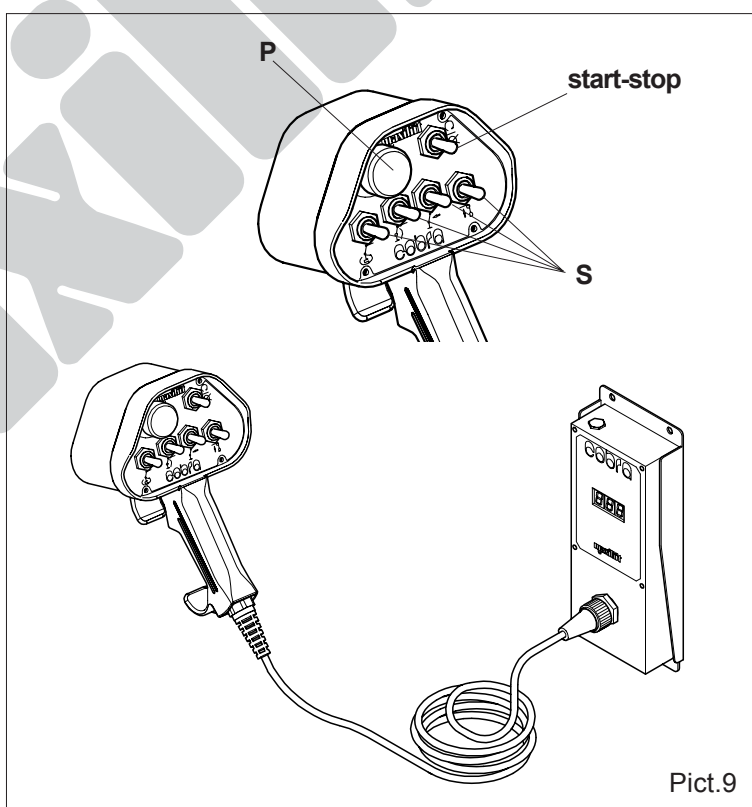

### 6.5.1 THE RADIO TRANSMITTING BUTTON STRIP (Pict.10)

It is identical to the above described cable one as far as the operator interface is concerned.

The main difference is the absence of the integral cable, which is replaced by a connector fixed to the handle base suitable for connection of the batteries power supply cable (1).

This cable of 1.5 mt. length is supplied on issue. It allows to charge the button strip batteries and, while connected, can be used to activate the crane by cable.

The rechargeable batteries are located in a proper protected space (2) inside the button strip, and can be easily removed by unplugging a small quick connector.

Batteries recharging when they are completely discharged can require up to three hours.

Inside the button strip there is the radio transmitting module.

A green led lights up permanently by activating whichever function to show that the transmitter is activated. The approaching to low battery condition is indicated by the led flashing while keeping a function activated. The remote control box must be opened only to carry out some repairs, or when checking for possible anomalies.

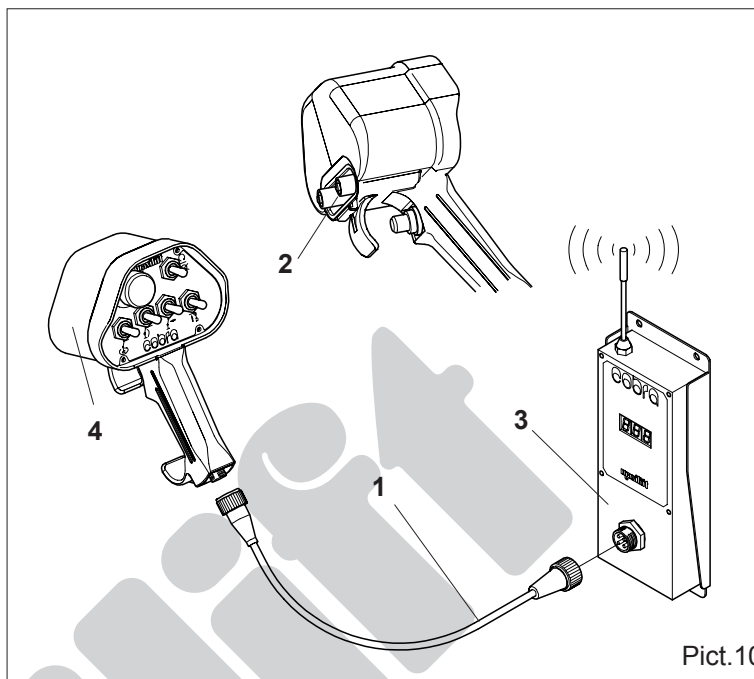

**ATTENTION**

**Before operating the radio remote control, check the perfect functioning of the emergency button.**

**During the pauses, the radio remote control must be absolutely switched off by pushing the emergency button.**

In order to check the emergency button functioning proceed as follows:

- Operate one function (ex.: boom lifting), checking that it is carried out by the crane
- Then push the emergency button, and check that the function previously carried out immediately stops. If this does not happen, stop immediately the crane.

**N.B. Never let the crane work with disabled emergency button.**



**ATTENTION**

**The pendant must be unplugged from the control unit connector on which the protection cover will be screwed.**

**After the use, push the emergency button of both cable and radio remote controls push button panels, before recovering them in a safe and protected place.**

**The radio button strip has a battery endurance between 12 and 24 hours according to the type of use. We recommend to discharge as much as possible the batteries before recharging them.**

## 6.6 PROPORTIONAL MONO-FUNCTION REGULATION HYDRAULIC UNIT (Pict.11)

The unit is consisting of two separate aluminium blocks.

The upper section includes the proportional adjusting valve (**VR**) and the manual bypass control valve (**OM**) of the proportional regulator.

The lower section includes the main relief valve (**VM**), the dump valve (**EV9**) and the control solenoid valves (**EV...A – EV...B**), two for each movement.

The solenoid valves: **EV9 – EV3B – EV2B – EV1B – EV1A** are equipped with a manual override, to be used only for emergency (failure of the electronic control unit or the button strip, lack of power supply).

In such cases it is necessary to proceed as follows:

- a) Fully turn counter-clockwise the valve handwheel (**OM**) in order to bypass the proportional valve (**VR**)
- b) Fully turn counter-clockwise the manual override of the valve coupled to the desired movement (extension re-entry, boom lowering, etc.).
- c) Finally fully turn counter-clockwise the manual override of the valve (**EV9**), in order to activate the desired movement
- d) once the standard working conditions of the crane are restored, always remember to close completely the manual overrides, by turning them clockwise.
- e) Finally close completely the bypass valve (**OM**) by turning the handwheel clockwise.

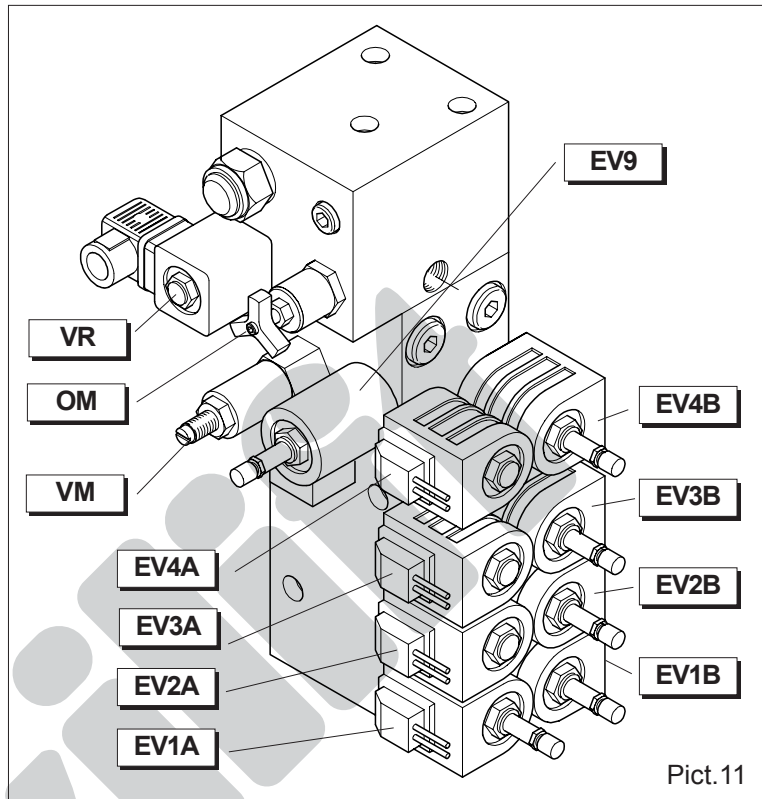

Pict.11

### 6.6.1 PROPORTIONAL DUAL-MODE REGULATION HYDRAULIC UNIT (Pict.12)

The unit is consisting of two separate aluminium blocks.

The upper section includes the proportional adjusting valve (**VR**), the manual bypass control valve (**OM**) of the proportional regulator, the main relief valve (**VM**), the winch operating solenoid valves (**EV4A – EV4B**), the dump valve (**EV9**) and the solenoid valves (**EV3 – EV4**) required to operate the winch and another function at the same time.

The lower section includes the control solenoid valves (**EV...A – EV...B**), two for each movement.

The solenoid valves: **EV9 – EV3B – EV2B – EV1B – EV1A** are equipped with a manual override, to be used only for emergency (failure of the electronic control unit or the button strip, lack of power supply).

In such cases it is necessary to proceed as follows:

- Fully turn counter-clockwise the valve handwheel (**OM**) in order to bypass the proportional valve (**VR**)
- Fully turn counter-clockwise the manual override of the valve coupled to the desired movement (extension re-entry, boom lowering, etc.).
- Finally fully turn counter-clockwise the manual override of the valve (**EV9**), in order to activate the desired movement
- Once the standard working conditions of the crane are restored, always remember to close completely the manual overrides, by turning them clockwise.
- Finally close completely the bypass valve (**OM**) by turning the handwheel clockwise.

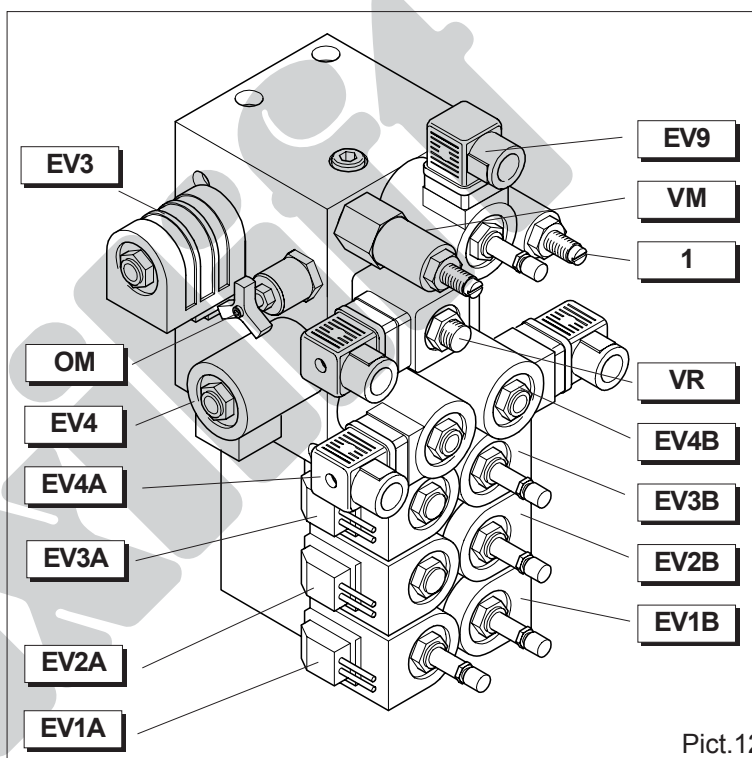

Pict.12

### 6.7 WIRING (pict.13)

The system is consisting of two fully independent wiring systems, which are connected to the electronic control unit through tight multipolar connectors (**1**) fitted with a quick coupling system.

The first wiring (**2**) includes the solenoids for the connection, of the operation valves which are located on the hydraulic unit, to the electronic control unit. The second wiring (**3**) connects the control unit to the safety stop ends (**FA – FB – FV**), to the pressure switch (**PM**), to the engine start/stop and to the power supply.

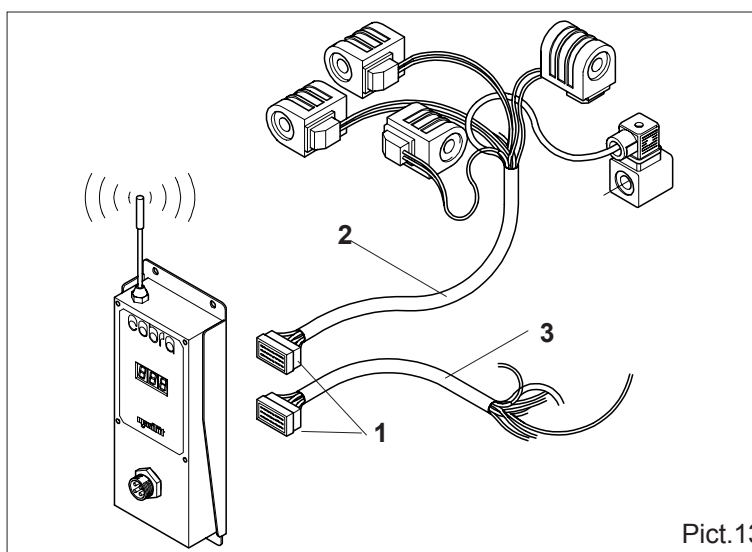

Pict.13

## 6.7.1 REMOTE CONTROL USE

After the preliminary operations concerning:

- PTO engaging
  - extension and lowering of stabilizer legs and their levelling
  - control system supply by switching on the proper switch inside the cabin
  - power supply by turning the battery-disconnecting lever in case of electro-hydraulic crane
- you can go on working with the remote control.

## 6.7.2 USE OF THE MONO-FUNCTION PROPORTIONAL REMOTE CONTROL

It is necessary to select the desired movement by pushing the selector (**S**) upwards or downwards (check carefully the symbols on the panel; the opposite movements are carried out by inverting the movement).

While keeping the selector pushed act gradually with your forefinger on the proportional button (**P**), in order to get a gradual speed increase. Proportionally to the stroke of the button, you will get a movement of the selected function which will be quicker and quicker until you achieve the maximum speed.

### ATTENTION

**Do not operate the proportional button before selecting the movement: it will not work.**

**Do not pull immediately the proportional button to its maximum limit: you will not get the right gradualness and the movements will be jerking and dangerous.**

**Always release first the proportional button, and then the selector of the movement chosen.**

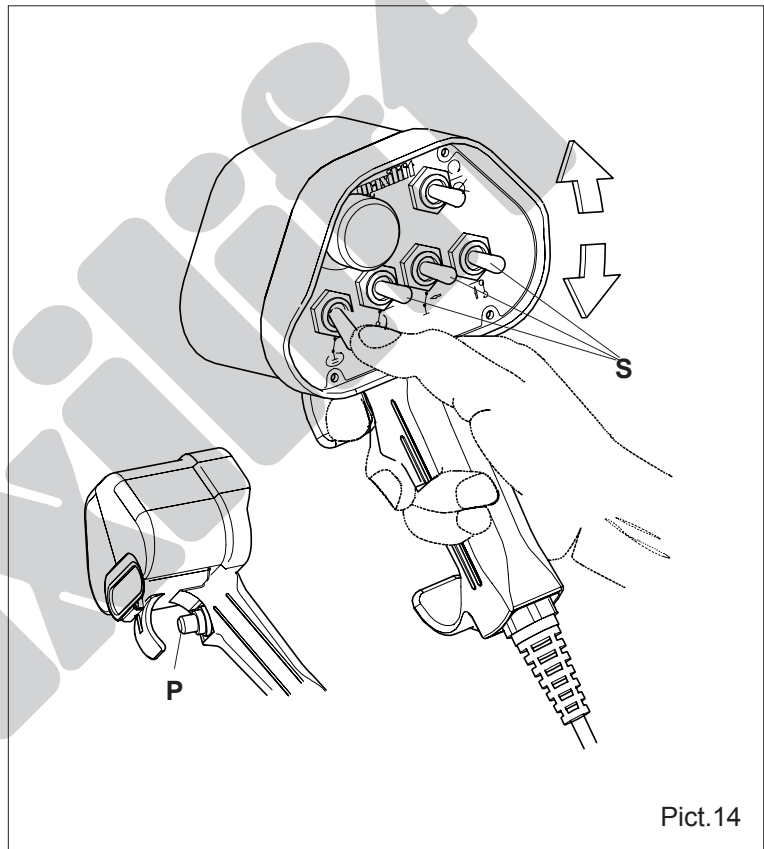

Pict.14

## 6.7.3 USE OF THE DUAL-MODE PROPORTIONAL REMOTE CONTROL

The dual-mode remote control can be normally used as a mono-function remote control when following the instructions of previous paragraph.

The remote control in object allows the combination of two movements at the same time by coupling the winch function (raising or lowering) to one of the remaining movements.

You always have to select first the two functions chosen, and then to operate the proportional button metering the speed, in order to achieve the desired speed, even allowing at the same time the winch rope raising or lowering.

By releasing one of the movements the speed of the other one does not increase until the function is stopped. By this way of operating the two speeds are nearly halved in comparison to the use of a single function.

## 6.8 DISPLAY MESSAGES

As previously explained, the electronic control unit is fitted with a 3 digits display showing messages which help the operator understanding if everything is working properly, the operating state and the functioning of its electrical components.

The operator, when led by an expert or following basic operations, can actually read on such display different messages helping him locating possible electrical anomalies on the system. This is a great help for searching and identifying possible faults, preventing useless and unsuitable interventions by the after-sales service.

Against possible displays of error messages, the operator is requested to contact the Technical After-Sales Service.

### 6.8.1 NORMAL DISPLAY MENU

When switching on, after a sequence of messages on the display this must show:



When carrying out whichever movement by selecting the function it must appear:



When the crane goes gets locked by the LLD (**overload**) the display shows:



In this case you have to carry out the manoeuvres allowing the overload reduction, i.e.: extension re-entry or winch lowering.

Moreover, the system can show the following error messages, which can be displayed when operating or trying unsuccessfully to operate.



The messages and relevant meanings are the following:

“**O**”**xx** followed by the solenoid valve abbreviation.

It means open circuit detected on the solenoid valve in object.



“**C**”**xx** followed by the solenoid valve abbreviation.

It means “short circuit” detected on the solenoid valve in object.



Examples:

Open circuit alarm on solenoid valve **EV3B**.

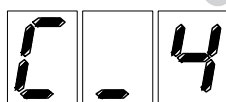

Short circuit alarm on solenoid valve **EV4**.

The following table shows all the displayed alarm codes.

<i>Display</i>	<i>Alarm Type</i>	<i>Valve on which the alarm is detected</i>
<b>O1A</b>	open circuit	EV on/off 1A (CLOCKWISE ROTATION)
<b>O1b</b>	open circuit	EV on/off 1b (COUNTER-CLOCKWISE ROTATION)
<b>O2A</b>	open circuit	EV on/off 2A (BOOM UP)
<b>O2b</b>	open circuit	EV on/off 2b (BOOM DOWN)
<b>O3A</b>	open circuit	EV on/off 3A (TELESCOPIC BOOM OUT)
<b>O3b</b>	open circuit	EV on/off 3b (TELESCOPIC BOOM IN)
<b>O4A</b>	open circuit	EV on/off 4A (WINCH DOWN)
<b>O4b</b>	open circuit	EV on/off 4b (WINCH UP)
<b>O_3</b>	open circuit	E3
<b>O_4</b>	open circuit	E4
<b>O_9</b>	open circuit	E9 (venting)
<b>O_r</b>	open circuit	VR (proportional valve)
<b>C1A</b>	short circuit	EV on/off 1A (CLOCKWISE ROTATION)
<b>C1b</b>	short circuit	EV on/off 1b (COUNTER-CLOCKWISE ROTATION)
<b>C2A</b>	short circuit	EV on/off 2A (BOOM UP)
<b>C2b</b>	short circuit	EV on/off 2b (BOOM DOWN)
<b>C3A</b>	short circuit	EV on/off 3A (TELESCOPIC BOOM OUT)
<b>C3b</b>	short circuit	EV on/off 3b (TELESCOPIC BOOM IN)
<b>C4A</b>	short circuit	EV on/off 4A (WINCH DOWN)
<b>C4b</b>	short circuit	EV on/off 4b (WINCH UP)
<b>C_3</b>	short circuit	E3
<b>C_4</b>	short circuit	E4
<b>C_9</b>	short circuit	E9 (venting)
<b>C_r</b>	short circuit	VR (proportional valve)

The system, through simple operations, allows to enter other menus, which can be helpful for the operator or a technician from the After-Sales Service. These menus are:

- MICRO-SWITCHES AND PRESSURE SWITCH DISPLAY MENU
- CURRENT DISPLAY MENU (for proportional valve adjustment)
- REMOTE CONTROL BUTTON STRIP DISPLAY MENU

There are other menus for adjustments and settings, needing test devices normally not available for operators, rather for the After-Sales Service.

- CALIBRATION MENU
- PROPORTIONAL BUTTON ACQUISITION MENU

### 6.8.2 MICRO-SWITCHES AND PRESSURE SWITCH DISPLAY MENU

This menu is accessed from the Normal Display Menu through the following procedure:

push the proportional button to its maximum level, then operate the 1A and 3B movements simultaneously for at least 5 seconds.

In this menu the state of FA, FB, FV, PM micro-switches are displayed cyclically, with a 2.5 seconds interval; each micro-switch can be in one of the following conditions:

- O** open
- C** closed

Example: display of the state “**FB micro-switch open**”

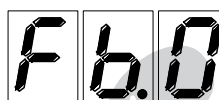

Example: display of the state “**PM micro-switch closed**”



The following table shows all displayed codes:

<b>Fa.O</b>	<b>Fa.C</b>	micro-switch <b>FA</b>
<b>Fb.O</b>	<b>Fb.C</b>	micro-switch <b>FB</b>
<b>Fu.O</b>	<b>Fu.C</b>	micro-switch <b>FV</b>
<b>Pr.O</b>	<b>Pr.C</b>	micro-switch <b>PM</b>

When no operation is activated the electronic control unit automatically switches to the Normal Display Menu after 60 seconds; otherwise a new power-on is required in order to get out of this menu.

### 6.8.3 CURRENT DISPLAY MENU

This menu is accessed from the Normal Display Menu through the following procedure:

push the proportional button to its maximum level, then operate the 1A and 4B movements simultaneously for at least 5 seconds.

In this menu, when no operation is active, the indication “Cur” is displayed. When a movement is active the value of the current (in mA) that is driving the proportional solenoid valve is displayed.

Example: indication without any active movement

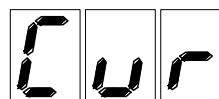

Example: indication with an active movement and with the proportional valve driven at 523 mA



When no operation is activated the electronic control unit automatically switches to the Normal Display Menu after 60 seconds; otherwise a new power-on is required in order to get out of this menu.

### 6.8.4 REMOTE CONTROL BUTTON STRIP DISPLAY MENU

This menu is accessed from the Normal Display Menu through the following procedure:

push the proportional button to its maximum level, then operate the 1A and 2B movements simultaneously for at least 5 seconds.

In this menu, when no operation is active, the indication “\_ \_ \_” is displayed. When a movement is active the state of the contact that activates the movement in the remote control pendant is displayed. For each of the contacts the following state is displayed:

**C** closed

In case of multiple command (two or more movements activated simultaneously) only the state of the first received command is displayed.

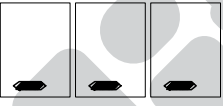
Example: indication without any active movement 

Example: indication when the contact 1A is closed on the remote control uni 

The following table shows all displayed codes:

<i>Display</i>	<i>Indication</i>
<b>C1A</b>	contact 1A closed (CLOCKWISE ROTATION)
<b>C1b</b>	contact 1B closed (COUNTER-CLOCKWISE ROTATION)
<b>C2A</b>	contact 2A closed (BOOM UP)
<b>C2b</b>	contact 2B closed (BOOM DOWN)
<b>C3A</b>	contact 3A closed (TELESCOPIC BOOM OUT)
<b>C3b</b>	contact 3B closed (TELESCOPIC BOOM IN)
<b>C4A</b>	contact 4A closed (WINCH DOWN)
<b>C4b</b>	contact 4B closed (WINCH UP)
<b>C5A</b>	contact 5A closed (START)
<b>C5b</b>	contact 5B closed (STOP)

When no operation is activated the electronic control unit automatically switches to the Normal Display Menu after 60 seconds; otherwise a new power-on is required in order to get out of this menu.

## 7 OPERATING INSTRUCTIONS

### 7.1 GENERAL ATTENTIONS

The crane must be used exclusively by qualified and skilled operators. They must know location and function of every control, instruments, indicators, lights, plate and sticker.



**Before starting operations make sure that nobody is in the working area of the crane.**

- The crane must work only on flat ground.
- Make sure that the truck is well braked and, if necessary, apply blocks to the tires.
- Pull the outrigger's beams out of their housing till the yellow line painted on it is completely visible, and make sure that the safety pins on the box are perfectly hooked on the beams.
- Lower the outriggers pads down to the ground. Be sure of not entirely lifting up the truck suspensions. It is important for the truck stability that a part of the truck weight still burdens on the tires.
- When swinging outrigger jacks are supplied check that it is in vertical position and with its safety pin inserted in its housing and well secured (see picture 18).
- When lowering the outrigger jacks stay away from them, to avoid crushing of feet and legs.
- Never operate the crane without having checked that the outriggers are well positioned on firm ground. If necessary, their bearing area must be increased with additional pads. The truck stability relies very much on the working conditions! When the ground under the outrigger pads is sinking, their bearing area must be increased. The crane Manufacturer can supply additional plates with increased area.
- Be sure that the lifted loads are, for every outreach, not higher than those stated on the load chart.
- Before operating the crane be sure that all the pinned joints and the hook pin are safely locked by their retainers.
- Lifting tackles, chains or ropes must be applied to the hook in such a way that will not damage the hook safety latch.
- Whilst swinging the boom always keep the load suspended from the ground. Dragging of the load is forbidden.
- Never stay or walk under hanging loads or within the operating radius of the crane.
- Do not use the crane near electric power or telephone lines.
- Never start the crane operation without signaling it in a proper way.
- The load should never be lifted or carried on areas where people are passing or working. If this cannot be avoided in any way, these operations must be properly signaled.
- Before leaving the controls, make sure that the control switches are in neutral position, the main switch is turned off and the load is resting on the ground.
- When the working area of the crane cannot be clearly seen from the operator control deck, a second operator charged with signaling is required (see pag. 31).
- Stay away from the outrigger beams when they are pulled in, to avoid crushing hazard between them and the truck parts.
- When the work is over make sure that the outriggers beam are locked in rest position and the shut-off valves are closed. Lack of doing this may result in serious danger if these parts come out whilst traveling on road.
- The stickers and plates applied on the crane are necessary to enable a safe usage of the same. Should them be no longer readable, replace them as soon as possible with new ones.
- Always disconnect the power take-off before driving away. If the truck engine turns at high revs, the PTO could be damaged.
- The operator should be someone who is familiar with type of crane and has had some experience with it.
- If the crane is accidentally hit, it has to be checked and tested from the closest authorized installer workshop.

- Check every month the state and correct functioning of all the parts subject to wear: pins, valves, hoses, sliding pads and bushings, etc. If necessary replace with genuine spare parts.
- It is absolutely forbidden to alterate the hydraulic circuit and open the safety seals. Failure to comply will cause automatically the voiding of any warranty on the product. Valves adjustments or setting must be done only by authorized installer workshops.
- Overheating of hydraulic oil may burn the sealing parts and alterate the oil itself. This can be caused by an excessive oil flow of the pump or by repeated stroke ends of the cylinders.
- Check that the pump supplies the control valve with the oil flow suggested in our technical specifications.

## 7.2 STABILIZING THE TRUCK

- Bearing in mind the job to be done, the vehicle has to be positioned in the most convenient position, stopped with the parking brake and the tires blocked.
- The truck engine shall be kept idling (800/900 rpm).
- The hydraulic circuit of the crane shall be activated as follows:

### **Cranes with pump driven by a power take-off**

Engage the PTO by means of the appropriate air switch (normally located in the cab), while depressing the clutch pedal.

If a mechanical coupling system is installed, the lever is behind the driving seat.

### **Cranes on stationary mounting**

Switch-on the hydraulic power pack.

### **Cranes driven by DC power pack**

The DC power pack is connected with the truck battery. The connection is made turning on the emergency button (Pict. 9, P) located on the remote control. The electric pump will start every time a switch of the remote control is moved. The crane can work even when the engine of the truck is off, but it is strongly recommended of keeping the engine idling, so the alternator can continuously charge the battery of the vehicle.

## **DANGER**

**DC electric motor overheating. Keep the electric pump running for short periods to avoid its over heating. The maximum working period of the pump depends on the pressure requested by the maneuvers, but should never exceed 10÷15 minutes in any case, with intervals of 20 min. to enable a sufficient cooling.**

## **IMPORTANT**

**In cold weather and in winter it is advisable to wait a few minutes with the pump running at no load before starting to operate the crane. (only for PTO - driven cranes)**

- Extend the outriggers beam. Its release is made turning 180° upwards the locking handle (2) on picture 15. Pull the beam (1) on picture 15 out for a length of approx. 20 cm (8 in.), then turn again the locking handle 180° downwards in its previous position. Pull again out the outrigger beam, and the locking pin of the handle will automatically engage and lock the beam when its working position is reached. Always extend fully the outrigger beam to its working position (i.e.: maximum opening position) to grant the maximum stability of the vehicle and safety. Always pull and push the outrigger beam acting on the handle (3) on picture 15 foreseen for this purpose, never pull the hoses or piping.

**△ ATTENTION**

The outrigger beam is in its working position when the yellow band existing on the beam can be entirely seen.

- Lower to the ground the bearing pads of the outriggers jacks, one at a time, acting as follows:

**Hydraulic jack (Fig. 16)**

Open the shut-off valve (1) to allow the lowering to ground of the cylinder's pad and rod (2). The valve is open when its lever is on position "A". Operate the corresponding lever of the control valve until the pad reaches the ground. Avoid to lift the truck off the ground unloading the vehicle suspension, this reduces greatly the stability of the truck. Then, turn again the valve lever to its previous "C" closed position.

**Mechanical jack (Fig. 17)**

Lower the pad (4) by pulling the locking pin (5) out of its housing. The telescope and the pad will come down because of gravity. When it is close to ground, engage again the pin in the appropriate hole, securing it with the relevant safety retainer (6). Turn the crank handle (7) until the ground is reached, bearing in mind what was explained above regarding the vehicle suspension.

**Swinging hydraulic jack (Fig. 18)**

When swinging jack are fitted, before operating the shut-off valve (1) make sure that the jack (2) is in vertical position, with its pad (3) oriented downward, its pin (4) secured with the retainer spring (5). If not, take off the pin, turn the jack downward and then lock in the working position in the aforesaid way. Then open the valve (1) as already explained (hydraulic jack), operate the corresponding lever of the control valve and lower the pad to the ground as described before. When duly positioned, close the valve (1) as described.

**△ ATTENTION**

When turning the swinging jack and removing its pin, be careful and hold it up, to prevent it from falling down because of gravity, resulting in damage or injuries.

- Repeat this sequence of operations for the outrigger jack on the other side of the truck and for every other jack fitted on the truck. Make sure that the vehicle is leveled, in order to have a good stability. Maximum allowed angle is 3°.

**△ IMPORTANT**

Proper leveling has to be checked by means of a level instrument fitted on the truck.

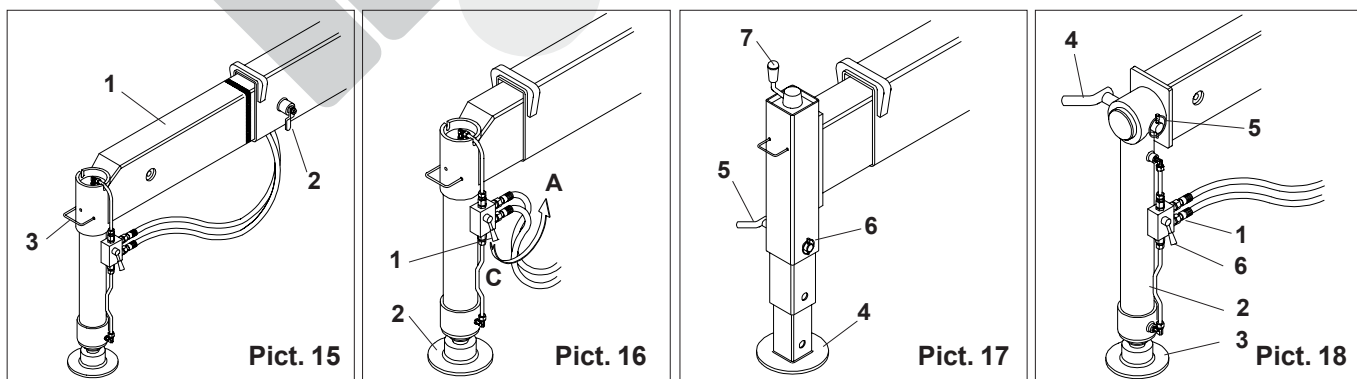

## 7.3 OPENING THE CRANE

- Starting from the crane in rest position, operate the switch of „boom hoist up“ on remote control. When the boom is roughly horizontal or in any case, higher than vehicle sides or other existing obstacles.
- Then operate the switch “crane swing”, to direct the boom in the desired direction.
- Then operate the switch “boom section extend” until the hook has reached the required position.

## 7.4 CLOSING THE CRANE

Closing the crane into rest position is performed by carrying out the opposite movements to those made to open it, taking special care, at the end of the operation there are no parts protruding from the truck size. Push the emergency button on the control board, disconnect the control board connection and save it in the driver's cab.

## 7.5 WINCH SYSTEM OPERATION

The Winch is mounted at the rear of the first section boom. It has capacities totally independent of the rest of the crane and can normally pull more than the crane itself can withstand. Therefore, care must be taken to insure that the load being lifted is within boom rating. To lift some of the heavier loads on the capacity chart, it will be necessary to multiple-part reeve the winch block to increase the lifting capacity of the winch (the speed is proportionately slower) and remain in the strength limitations of the winch and wire rope. The winch load rating chart on each machine provides the information for pull limitations on the winch with various applicable part reevings. These ratings are based on providing the proper operating safety factor on the wire rope supplied with the machine. Therefore, any replacement rope must meet the rope specifications for size, construction and strength as outlined in specification sections of this manual.

## 7.6 BEFORE STARTING TRAVELING ON ROAD

Make sure that:

- The crane is in rest position as specified on chapter 7.4.
- The emergency button must be pushed
- The control board connection has been taken off the remote control and put in its box in the driver's cab.
- The outriggers jacks are fully retracted, their stop pins are in their housing and secured with relevant retainers.
- The manual boom sections, if installed, are secured with stop pins and safety retainers.
- The locking handle of the outrigger beams, (2) on pict. 15, is safely locked in place. Unexpected sliding out of the outriggers beams when the truck is traveling could result in serious accidents.
- The lever of the shut-off valve on hydraulic jacks, see (1) in pict. 16, is in the CLOSED position.
- The PTO is disconnected.
- The overall dimensions of the crane in rest position are complying to regulations standard.

### **NOTE**

**Always remember that if the crane is left open on the body and it overcomes the maximum height allowed by the law, it could hit bridges and other obstructions**

## 7.7 MAIN ERRORS OCCURRING WHEN OPERATING THE CRANE

Because of lacking of care or of adequate instructions, some dangers may occur during crane operation. Most common errors are:

- Slinging of loads exceeding the crane capacity: always check their actual weight not to overload the crane or the winch. Special care has to be taken when handling big loads, when free they can remain hanging on the crane and result in damages and accidents.
- A sudden stop when lowering a load. This creates high forces of inertia on the crane structure with relevant dangerous overload.

- Hitting the rope where the load is suspended, overload is generated.
- Side pull, dragging the load on the ground. All these operations originate strong overloading forces on the crane.
- The outriggers are badly positioned or the ground is not firm: in both cases the truck tilts and could tip over.
- Working with strong wind or wind gusts
- The manual boom sections are not correctly installed.
- The load is not correctly slinged. So the lifting accessory used (chain, rope, etc) breaks or flips out and the load falls down to earth. The boom, suddenly unloaded, springs back and this could result in tipping over.
- Trying to lift fixed load up (rooting of trees, raising of culverts, etc). Even if their load is smaller than the capacity of the crane, the dynamic force created when it is suddenly stripped, may easily exceed the capacity, and make the truck tip over.
- Swinging movements of the load. When acting on the slewing control too suddenly, the load starts swinging. Danger of overload. And boom's breaking.

## 7.8 STANDARD HAND SIGNALS

STANDARD HAND SIGNALS FOR CONTROLLING CRANE OPERATIONS				
<p><b>SWING.</b> Arm extended, palm with finger in direction of swing of boom.</p>	<p><b>STOP.</b> Arm extended, palm down, move arm back and forth horizontally.</p>	<p><b>EMERGENCY STOP.</b> Both arms extended, palms down, move arms back and forth horizontally.</p>	<p><b>HOIST.</b> With left arm vertical, forefinger pointing up, move hand in small horizontal circle.</p>	<p><b>LOWER.</b> With arm extended downward, forefinger pointing down, move hand in small horizontal circle.</p>
<p><b>USE MAIN HOIST.</b> Tap on head, then use regular signals.</p>	<p><b>TRAVEL.</b> Arm extended forward, hand open and slightly raised, making pushing motion in direction of travel.</p>	<p><b>DOG EVERYTHING.</b> Close hands in front of body.</p>	<p><b>TRAVEL (Both Tracks).</b> Use both hands in front of body, making a circular motion about each other, indicating direction of travel: forward or backward (for land cranes only).</p>	<p><b>USE WHIPLINE (Auxiliary Hoist).</b> Tap elbow with one hand, then use regular signals.</p>
<p><b>RAISE BOOM.</b> Arm extended, fingers closed, thumb pointing upward.</p>	<p><b>LOWER BOOM.</b> Arm extended, fingers closed, thumb pointing downward.</p>	<p><b>TRAVEL (One Track).</b> Lock track on side indicated by raised hand, travel opposite track in direction indicated by circular motion of other hand rotated vertically in front of body (for land cranes only).</p>	<p><b>RETRACT BOOM (Telescoping Booms).</b> Both fists in front of body with thumbs pointing toward each other.</p>	<p><b>EXTEND BOOM (Telescoping Booms).</b> Both fists in front of body with thumbs pointing outward.</p>
<p><b>MOVE SLOWLY.</b> Use one hand to give any motion signal and place other hand motionless in front of hand giving the motion signal. Point slowly shown as example.</p>	<p><b>RAISE THE BOOM AND LOWER THE LOAD.</b> With arm extended, thumb pointing up, feet fingers are and out as long as load movement is desired.</p>	<p><b>LOWER THE BOOM AND RAISE THE LOAD.</b> With arm extended, thumb pointing down, feet fingers are and out as long as load movement is desired.</p>	<p>EXTRACTED FROM ANSI STANDARD ADDENDUM - B30.5b-1985 &amp; B30.5d-1988 THIS COMPLIES WITH OSHA STANDARDS</p>	

Pict. 19

## 8 PUTTING THE CRANE INTO SERVICE

### 8.1 TEN RULES FOR THE PERFECT CRANE OPERATOR

Always comply with the following ten basic rules:

- 1 - When approaching the crane for the first time, become on familiar terms with it, executing all the manoeuvres the crane can perform during working. Carefully read all the prescriptions of this manual and execute step by step the activities hereby described to be sure of the correct understanding.
- 2 - This manual must always be carried in the driver's cab along with a copy of the load chart.
- 3 - Every operation has to be planned with care.
- 4 - Get all the necessary information for reaching the working site: distance, itinerary, height of existing tunnels, capacity of the bridges to be crossed, etc.
- 5 - Study and plan the best way to operate the crane: soil consistence, weight and dimensions of the loads to be lifted, height to be raised and necessary booms outreach. Check available room or limitations due to the presence of buildings, obstacles, electricity power lines, etc.
- 6 - Make sure of availability of all the necessary equipment: accident-prevention clothings, additional bearing plates with increased surface area, slings, hooks, ropes and chains of certified origin and in perfect conditions.
- 7 - Before starting crane operations check the efficiency of the safety control devices. Never use the crane if the correct functioning of a device is not sure.
- 8 - Traffic and safety laws in force must be strictly observed both when travelling on road and when operating the crane.
- 9 - The warnings of these manual referred to special dangers are to be read and observed with special care.
- 10 - The safety during the crane service must be kept to the highest level carrying out a regular, constant and accurate preventive maintenance. Repairs if necessary should never be delayed, and must be made by specialized, authorized people using only genuine spare parts.

### 8.2 DAILY CHECK LIST

- Check the existence of oil leaks
- Check the correct working of the load limiting device.
- Check oil level and fill up if necessary
- Check the good conditions of hoses and piping
- Check the good conditions of painting and chrome plating
- Check the correct working of safety valves.

### 8.3 SAFETY TIPS FOR CRANE STARTING IN COLD CLIMATES

Only if the crane is PTO-driven: wait for some minutes with the pump running at no load before operate any crane movement.

### 8.4 CRANE PROTECTION AND STORAGE

#### 8.4.1 Short shutdowns

Wash and clean the crane, lubricate all the parts provided with grease nipples and the slewing system.

 **ATTENTION**

**Never wash the crane with chemical products or high pressure water jets, as they can cause the detaching of the stickers water entering inside the electrical components and the slewing case.**

### **8.4.2 Long shutdowns**

Same precautions as above and, moreover:

- apply protective oil on the entire crane surface
- cover the crane using a plastic curtain against rain etc.
- store in a dry place, under roof
- disconnect the connections to the truck battery.

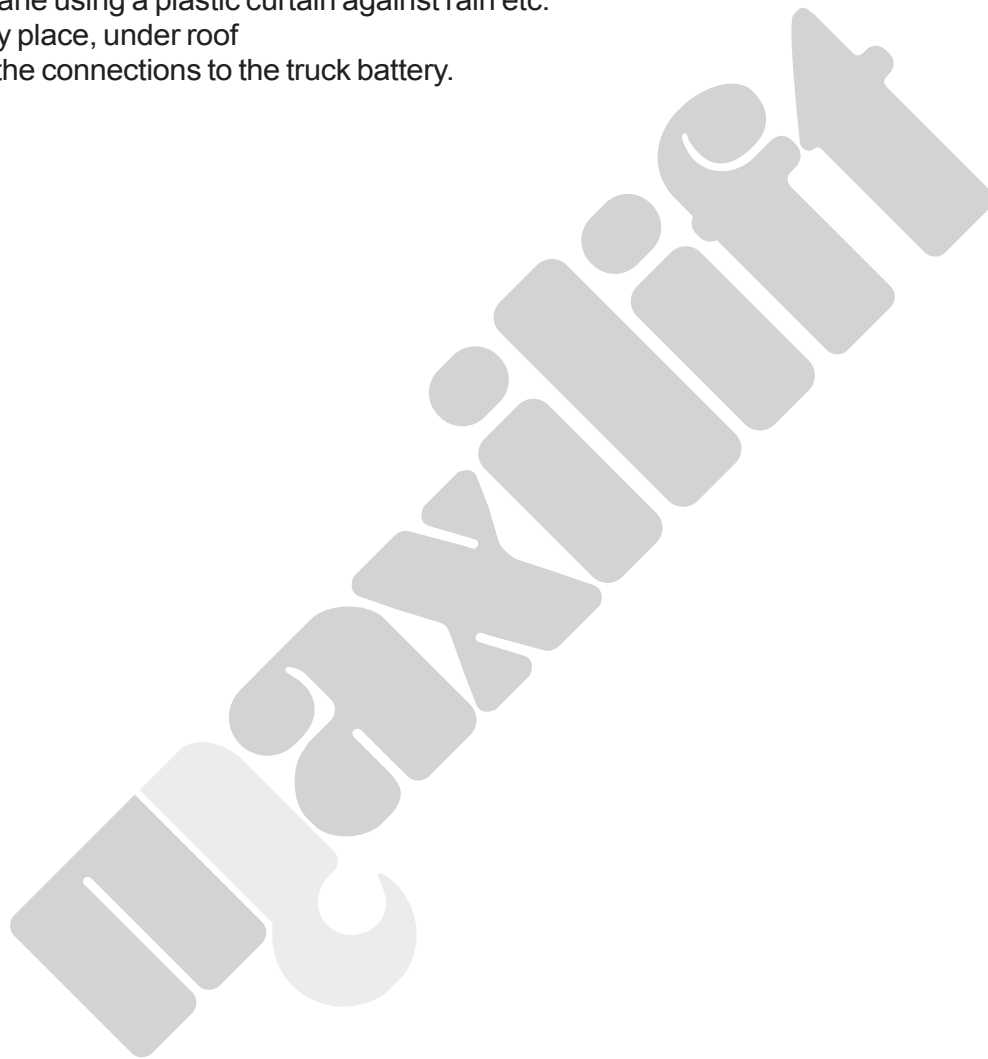

## 9 MAINTENANCE

### 9.1 WARNINGS

- Do not wear rings, wristwatches, jewelry, loose-fitting or hanging clothing such as ties, torn garments, ordinary shoes, unbuttoned jackets or un-zipped overalls, which could get caught up in the moving parts of the crane. Instead, always wear approved accident-prevention clothing such as protective helmets, anti-slip shoes, anti-noise headphones, protective glasses, and reflective jackets with breathing apparatus. Consult your employer concerning current safety regulations and accident-prevention equipment.
- Apply a clearly visible plate on the cab door or on the control valve with the notice: "crane under maintenance. Do not start"
- Do not get under any raised part of the crane, unless a safety lock support has been applied to it.
- Before starting any maintenance or repair operation always install safety locking supports on any raised part of the crane, especially the boom system.
- Do not jump into or out of the machine, always use adequate steps and handrails.
- The truck engine should be started in closed rooms only if well aired.
- Before operating the crane make sure that nobody stays or walks in the working area.

### 9.2 MAINTENANCE PRESCRIPTIONS

- Many damages and accidents are caused by a bad maintenance or by mistakes in the maintenance itself. Common causes are recognized to be:
  - leaking of oil, grease or anti-freeze liquid.
  - dirt on crane components or assemblies.
  - breaking of ropes or slings.
  - safety valves, load limiting device or other safety devices out of service or not in good working conditions.
  - hydraulic plant in bad conditions, for instances: hoses damaged, loose hydraulic fittings, etc.
- Every maintenance work has to be carried out with care.
- Do not delay repair or maintenance works on the crane.
- Repair works must be assigned only to qualified, skilled people.
- The recommended procedures of repair and maintenance must always be followed carefully. If necessary ask for a preventive authorization.
- Before taking any part away of the crane, always switch the motor off and be sure that the pressure in all the circuits has been discharged. See relevant manual.
- Do not put the head or fingers or feet or arms or any other part of the human body into an area where the danger of shearing or crushing exists, if the parts of the machine have not previously locked in a safe way.
- Do not use your fingers to align holes or slots: always use appropriate centering tools.
- Wear protective glasses with side shields to protect your eyes when using compressed air for cleaning the machine parts. Do not allow the pressure of the air to exceed 2 bar (29 psi).
- The access steps or platforms in the workshop or where the crane is operated must be built according to current hazard avoiding regulations.
- Never use petrol or thinners or other flammable liquids or detergents. Use instead authorized commercially sold cleaning products which are granted to be non-flammable and non toxic.

 **DANGER**

**of fire or scald**

**It is forbidden to use naked flame as lighting device when carrying out checks or looking for leaks in the machine.**

- Do not lubricate, repair or carry out settings on the crane when it is working, unless this is expressly required in the instructions of the Operator's/Maintenance manual.
- If it is necessary to lift the crane and/or other parts, make sure that they are locked as requested from current safety regulations
- Always use approved protective clothing, safety gloves and protective glasses when using steel ropes, as they produce steel splinters.
- Never use the tools in a way different from the one they are meant, i. e.: pliers instead of wrenches.
- The maintenance area is to be kept clean and dry. Remove immediately any trace of water or oil.
- Leakage of fluid from a very small hole may be almost invisible and yet strong enough to penetrate the skin. Before starting looking for the leaks, it is important to wear protective glasses with side shields. Do not use your hands, use a piece of cardboard or wood to locate the source of the leak. Injuries caused by pressure fluid may result in serious infections, so it is recommended to contact immediately a doctor.
- Do not heap dirty rags with oil or grease, they may be a danger of fire. Instead, put them in a metallic closed case.
- Immediately replace any missing sticker or plate carrying a notice of danger, attention or other instructions.

 **IMPORTANT**

**Various part of the crane are manufactured with high tensile steel. Never perform any operation (welding, drilling, etc) without authorization and instructions from the manufacturer.**

**ATTENTION**

**The crane is supplied with electrical and electronic devices installed. Always disconnect the connections of these devices before carrying out welding or other operations with electric tools on the crane or on any part of the truck .**

- When repair or maintenance operation is over, before putting again the machine into service, make sure that any tool or other piece has not been forgotten in places containing moving parts, or close to them.
- The machine and its accessories has to be kept in good conditions.
- Replace failed or worn components with genuine spare parts or other approved by the Manufacturer.

## **9.3 MAINTENANCE SCHEDULE**

### **9.3.1 Daily checking**

- Check the level of hydraulic oil in the tank.
- Check the hoses, the fittings and all the other components of the hydraulic system, in order to eliminate any possible source of oil leak.
- Check that all the crane is in good condition.
- Immediately repair the item or the component found to be faulty.

## 9.3.2 Monthly checking

- Check the setting of the pressures in the hydraulic system, and integrity of the seals.
- Check the absence of oil leaks.
- Check integrity and tightening of crane tie rods and bolts.
- Check integrity and tightening of hoses, piping and their fittings.
- Check fastenings and safety devices.
- Check readability of symbols on the remote control.
- Check integrity of hooks, ropes, chain and all the other lifting ancillary equipment.
- Check that all the identification and warning plates are still applied and readable.
- Visually check all the structural components for any deformation, backlash or crack out.
- Clean oil filters.
- Check the oil level and lubricate accordingly to the lubricating and greasing chart.
- Check the regular working of the slewing system, grease with the suggested grease the worm and the worm gear, replace the grease brush spreader if worn.
- Make a working test of the crane, with and without the load, paying attention to possible unusual noises coming from the crane parts.
- Grease the hydraulic boom sections.

## 9.3.3 Checking every six months

- Wash and clean the crane



**Never wash the crane with chemical products or high pressure water jets, as they can cause the detaching of the stickers and water entering inside the electrical components and the slewing case.**

- Check the pressure settings in the hydraulic system.
- Check the absence of oil leaks.
- Check integrity and tightening of crane tie rods and bolts.
- Check integrity and tightening of hoses, piping and their fittings.
- Check fastenings and safety devices.
- Make a safety test of the hydraulic system.
- Check correct working of remote control and readability of relevant symbols.
- Check integrity of hooks, ropes, chain and all the other lifting ancillary equipment.
- Check that all the identification and warning plates are still applied and readable.
- Visually check all the structural components to find any deformation, backlash or crack out.
- Check the oil level and lubricate accordingly to the lubricating and greasing chart.
- Replace the filter of the hydraulic oil.
- Make a working test of the crane, with and without the load, take care of listening to strange noises coming from the crane parts.

## 9.3.4 Others

- Stability of unit throughout working area. Check stability procedure annually or when any change is made to crane or truck.

## 9.4 CRANE SERVICING

### 9.4.1 Oil level checking

The oil level must be checked daily, with the crane in rest position and the truck on flat ground. If necessary, top up with hydraulic oil. The level is checked by means of the dipstick. (1)

### 9.4.2 Oil change

The oil deteriorates during daily usage. The oil change every year is necessary to avoid damages to the hydraulic system. Take a container with a capacity of 40 liters (10 gal.) and having suitable dimensions to be positioned under the oil drain plug. (2)

## ATTENTION

**It is forbidden to pollute the environment with exhausted oil.**

After the replacement, it is important to carry out a bleeding of the circuit, otherwise the air introduced in the system with this operation may damage the sealing parts. To do that, operate every function of the control valve, driving it smoothly to stroke end.

Use only the oils stated in the greasing/lubricating table, or equivalent ones. (chap. 9.5)

### 9.4.3 Oil filter replacement

- Unscrew the screws (5) holding the filter case.
- Pull the case out without damaging the OR.
- Loosen the nut (5) and take the cartridge (4) off.
- Replace it with a new one, of the same type, and tighten the nut (5) again.
- Check the seal for satisfactory condition, if not replace by new one.
- Insert the filter group in its housing and tighten the relevant screws.
- After a filter replacement, bleed the air off the circuit as explained on point 9.4.2.

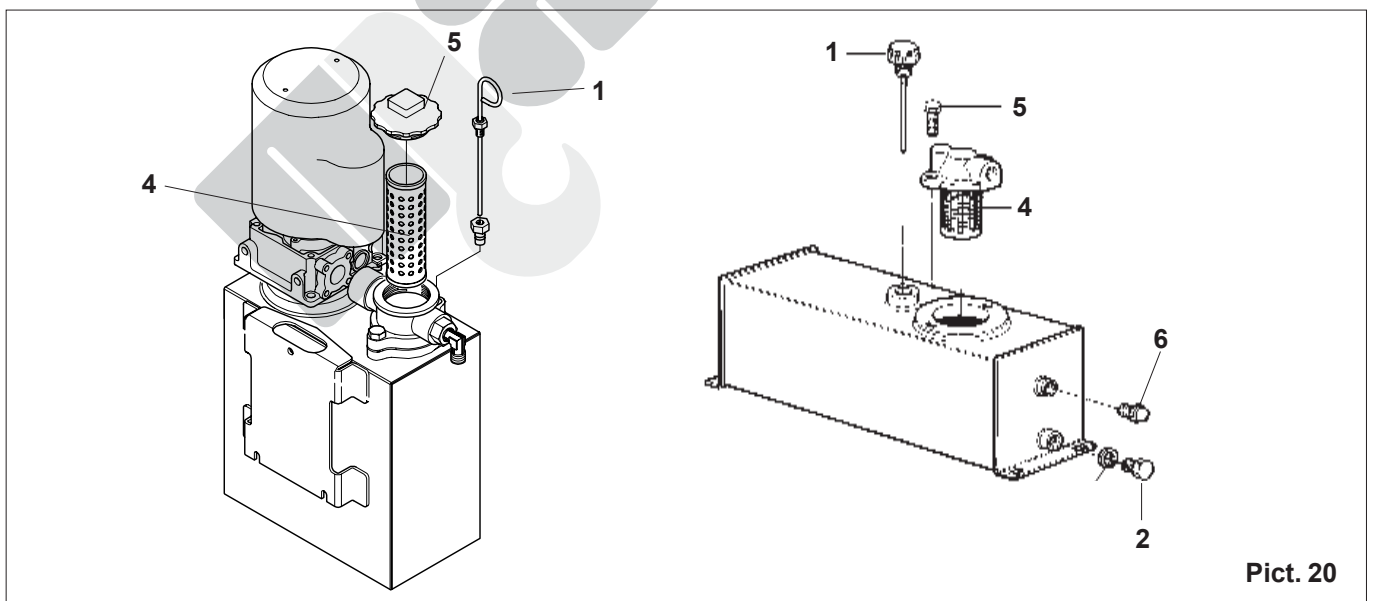

Pict. 20

## 9.4.4 Wormgear assembly control (Pict. 21)

It is important to check that the worm gear reducer has a correct axial backlash. This can be made, with the crane at standstill, the boom in horizontal position. Pushing the boom aside on the left and on the right by hand, you can notice if the axial backlash between the wormshaft (6) and the wormgear (8) is too great. In this case it has to be reduced, tighten the nut (7) accordingly. Grease the gear with the suggested product and replace the grease spreader (9), if worn out.

## 9.4.5 Greasing the hydraulic boom sections (Pict. 22)

- 1 - Completely extend the telescopic boom
- 2 - Grease the lower part of the extensions by a brush
- 3 - Grease the upper part of 1st. extension by the two grease nipples
- 4 - Grease the upper part of the 2nd. extension by the brush
- 5 - Carry out 2 or 3 boom re-entry and extension idling operations in order to allow the distribution of the grease

## 9.4.6 Wear pads check and replacement

Wear pads need to be replaced when their thickness drops under 5.5 mm (0.22 inch.)



### ATTENTION

Failure to replace the wear pads when they have reached the above stated wear limit, can prejudice to the good and safe operation of the crane.

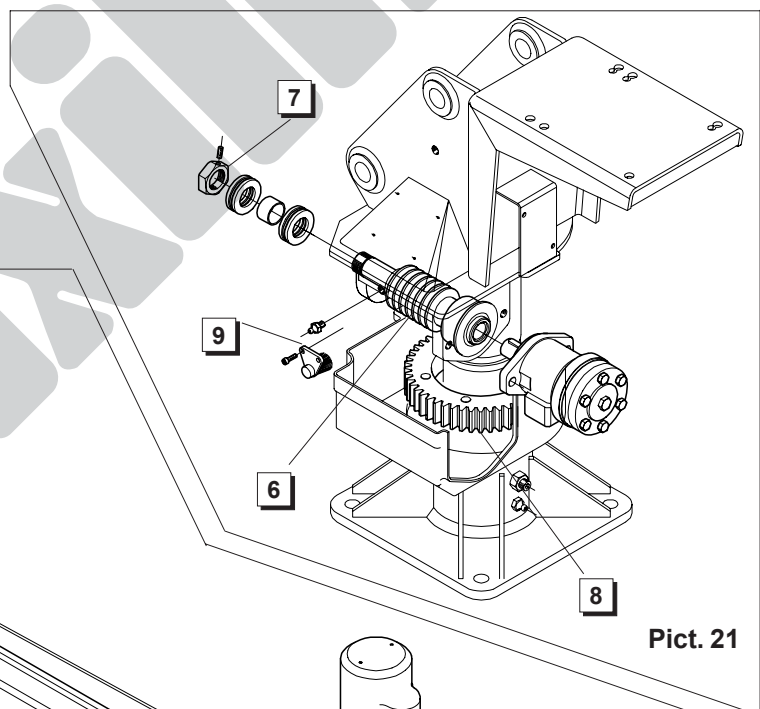

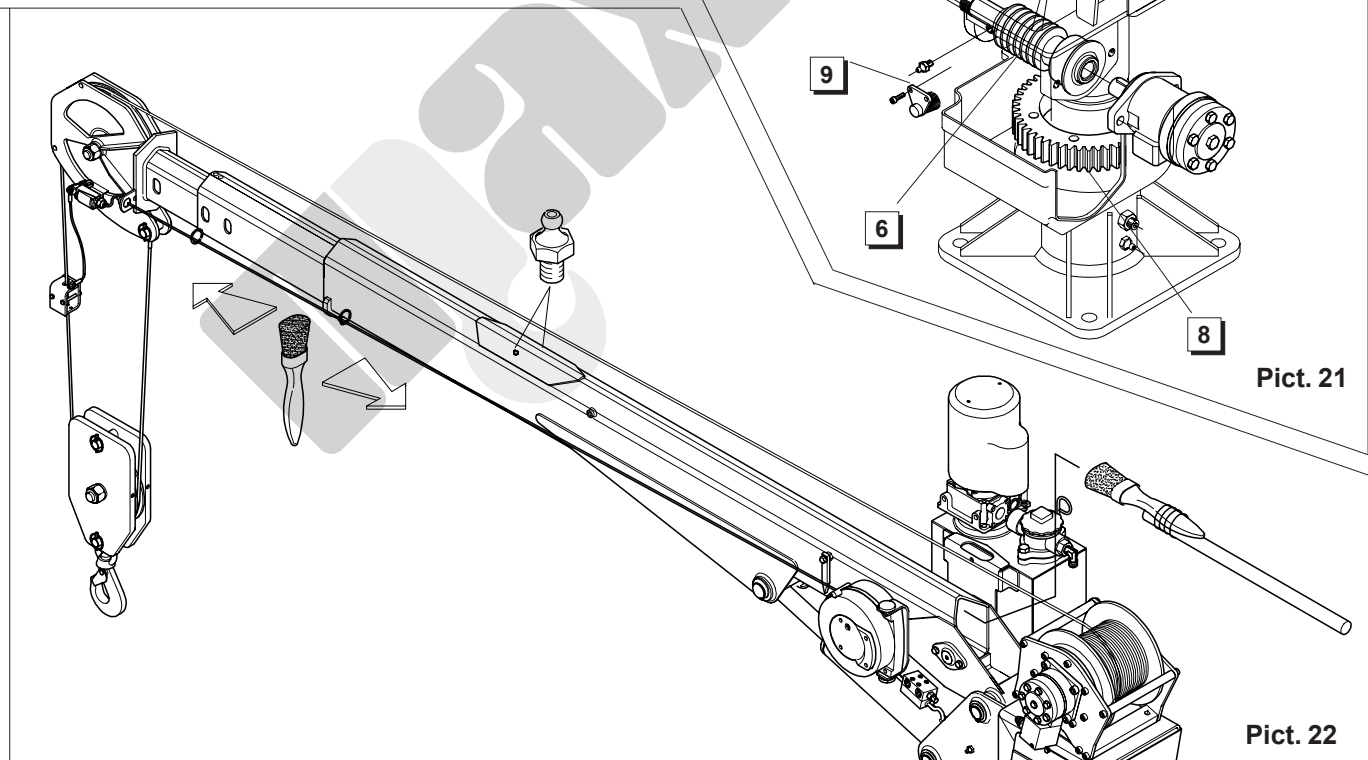

Pict. 21



Pict. 22

## 9.5 Greases and oils reference table

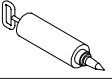
BRAND	TOTAL	MOBIL	ESSO	AGIP	IP	BP
GREASE 	MULTIS EP2	MOBILGREASE MP	BEACON EP2	GR MU EP2	ATHESIA EP2	ENEGREASE LR MP
GREASE 	MULTIS LR MP	MOBILGREASE MP	BEACOM EP2	GR MU EP2	ATHESIA EP2	ENERGREASE EP2
HYDRAULIC OIL 	AZOLLA ZS 46• ZS 48*	DTE 25	NUTO H 46• H68*	OSO 46• 68*	HYDRUS 46	HENERGOL HL 80
GREASE 	WINN'S (GS-80)					
<ul style="list-style-type: none"> <li>• for temperate and cold climate</li> <li>* for hot climate</li> </ul>						

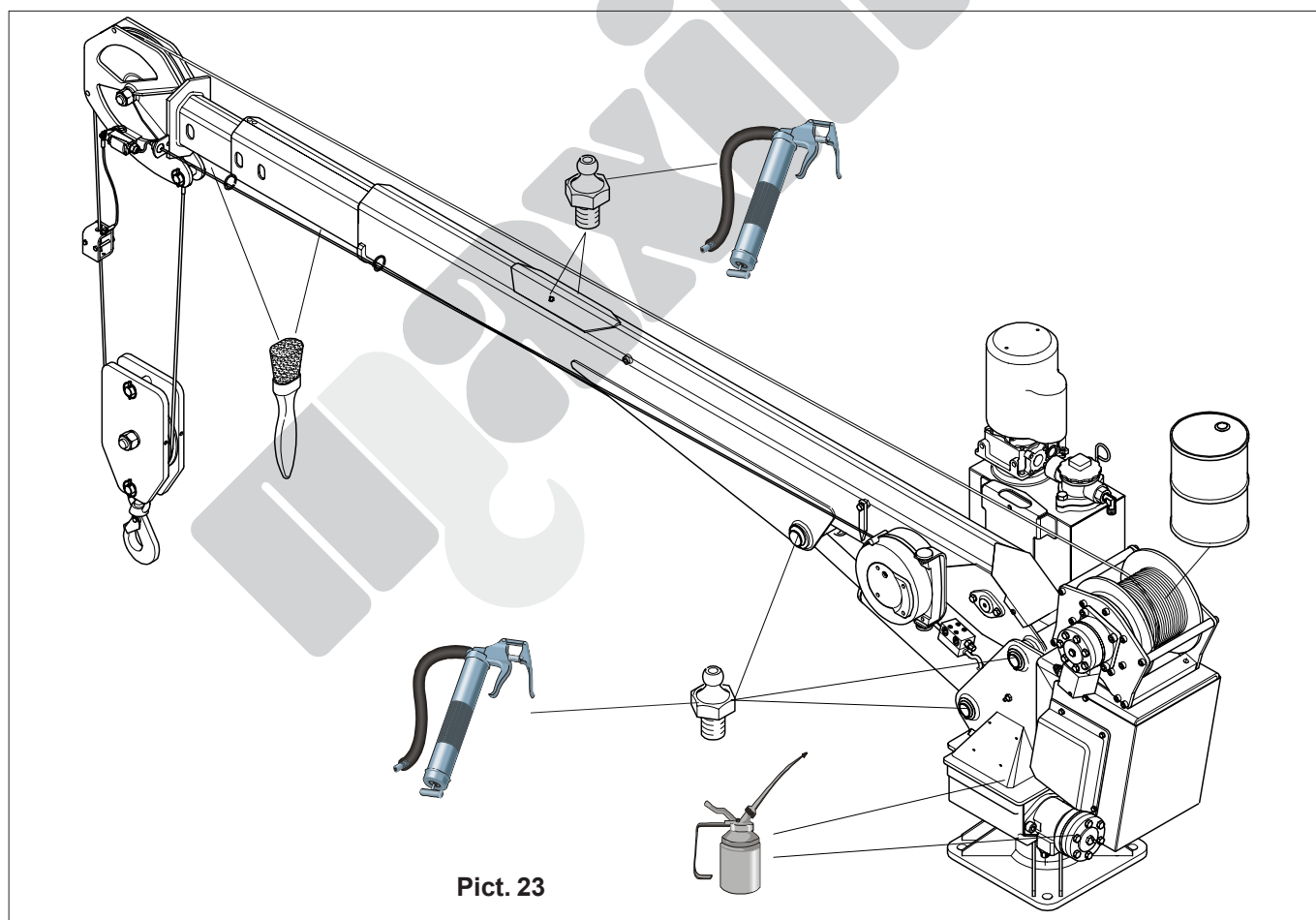

Pict. 23

## 9.6 WIRE ROPE

### 9.6.1 WIRE ROPE INSPECTION

Each day and before use, inspect the wire rope for the following conditions:

- |                           |                            |
|---------------------------|----------------------------|
| 1 - Kinking (Sharp bends) | 6 - Rope diameter loss     |
| 2 - Crushing              | 7 - Rope strand unevenness |
| 3 - Unstranding           | 8 - General corrosion      |
| 4 - Birdcaging            | 9 - Broken strands         |
| 5 - Core protrusion       | 10 - Cut strands           |



**Do Not open the rope for inspection. Inspect the rope daily or before use each day and also inspect the rope eye for abrasion, corrosion and broken wires.**







Inspect the wire rope monthly as follows:

- 1 - The entire length of the rope
- 2 - The wire rope eye

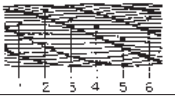
### 9.6.2 ROPE REPLACEMENT

It is extremely difficult to determine the exact time for replacement of wire rope since many variable factors are involved. Proper determination of the condition of a wire rope depends upon the good judgement of an experienced person in evaluating the remaining strength in a used rope after allowance for deterioration disclosed by inspection. The following reasons are sufficient justification for consideration of rope replacement:

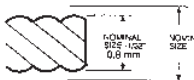
- 1-Six randomly distributed broken wires in one rope lay or three broken wires in one strand in one rope lay.

1 - When there are either 3 broken wires in one strand or a total of six broken wires in all strands in any one rope lay.	
2 - When flat spots on the outer wires appear and those outside wires are less than 2/3 the thickness of the unworn	
3 - When there is a decrease of diameter indicating a core failure	
4 - When kinking, crushing, birdcaging or other distortion occurs	
5 - When there is noticeable heat damage (discoloration) of the rope by any means	
6 - When the diameter is reduced from nominal size by 0.8 mm (1/32") or more	
7 - If a broken wire protrudes or lops out from the core of the rope	

### 9.6.3 WIRE ROPE LUBRICATION

Wire rope is lubricated during manufacturing so the strands, and individual wires in strands, may move and adjust as the rope moves and bends. A wire rope cannot be lubricated sufficiently during manufacture to last its entire life. Therefore, new lubricant must be added periodically throughout the life of a rope to replace factory lubricant which is used or lost.

The surface of some ropes may become covered with dirt, rock dust, or other material during their operation. This covering can prevent field applied lubricants from properly penetrating into the rope. Therefore, these ropes should be cleaned before being lubricated.

The lubricant applied should be light bodied enough to penetrate to the core of the rope. Lubricant may be applied effectively by various methods. It may be dripped on, sprayed on, or put on by brushing, but in any case it should be applied at a place where the rope is being bent, such as at a sheave. It should be applied at the top of the bend, because at that point the strands are spread by bending and are more easily penetrated. The service life of rope will be directly proportional to the effectiveness of the method used and amount of lubricant reaching the working parts of the rope.

A proper lubricant must reduce friction, protect against corrosion, adhere to every wire and be pliable and not crack or separate when cold and yet not drip when warm.

## 9.7 POSSIBLE FAULTS AND RELEVANT REMEDIES

Fault	Cause	Remedy
Vibrations in hydraulic cylinder and jerkin- gs at the first manoeuvres.	The temperature of the hydraulic oil is too low.	Perform manoeuvres without loads for some minutes to warm the oil up.
Vibrations with every functions when the oil is hot.	Lacking of oil in the tank. Air in the hydrau- lic system.	Add hydraulic oil to the tank.  Operate the control lever carrying the cylinders to stroke end for some times in both directions.
All the crane movements are very slow, even when unloaded.	Suction hose from oiltank crushed or obstructed.  The pump is drawing in air.	Replace or clean the suction hose.  Check that the relevant fittings are well tightened.
Crane rotation not regular.	The truck is not correctly levelled.  Worn slewing motor.	Level the truck.  Replace slewing motor.
The crane does not lift the loads of the load chart table.	Defective pump.  Uncorrect settings of the valves.  Hydraulic cylinder sealings are worn.	Replace the pump.*  Adjust valve settings.*  Replace worn sealings.*
The crane lift the load, but cannot hold it.	Uncorrect settings of the valves.  Hydraulic cylinder sealings are worn.	Adjust valve settings.*  Replace worn sealings.*
Noise coming from articulation points.	Lacking of lubrication.	Grease articulation points.
The hydraulic legs does not hold under load.	Defective holding valves.  Worn sealings in the stabilizer cylinder.	Clean or replace holding valves.*  Replace worn sealings.*
The crane locks with boom lifted at end course.	Pressure transducer not set.  Setting of general max. pressure valve too high.	Disassemble the casing and move ma- nually the boom descent valve (VB2). Reduce the general max. pressure valve
One or more movements keep on func- tioning while selecting another function.	- Solenoid valve jammed in open posi- tion (dirt, working shaving, long inacti- vity periods)  - Manual operator (where foreseen) activated	- Unlock, clean or in case replace the solenoid valve cartridge  - Close down the manual operator

Fault	Cause	Remedy
One function does not work	<ul style="list-style-type: none"> <li>- solenoid valve jammed in open position (dirt, working shaving, long inactivity periods)</li> </ul>	<ul style="list-style-type: none"> <li>- Unlock, clean or in case replace the solenoid valve cartridge</li> </ul>
Movements work always at full speed	<ul style="list-style-type: none"> <li>- Manual operator OM open</li> <li>- Proportional regulator VP jammed</li> </ul>	<ul style="list-style-type: none"> <li>- Close OM by turning the hand wheel clockwise</li> <li>- Check and in case replace VP</li> </ul>
No movement works	<ul style="list-style-type: none"> <li>- Lack of hydraulic supply</li> <li>- Solenoid valve EV9 (if present) jammed in open position</li> </ul>	<ul style="list-style-type: none"> <li>- Check the PTO or the electro-hydraulic power unit</li> <li>- Unlock, clean or in case replace the solenoid valve cartridge</li> </ul>
The winch does not work when single operated	<ul style="list-style-type: none"> <li>- Solenoid valve V4 jammed in closed position (dirt, working shaving, long inactivity periods)</li> </ul>	<ul style="list-style-type: none"> <li>- Unlock, clean or in case replace the solenoid valve cartridge</li> </ul>
The winch does not work when operated together with other functions	<ul style="list-style-type: none"> <li>- Solenoid valve V3 jammed in closed (dirt, working shaving, long inactivity periods)</li> <li>- Flow divider 1 wrongly set or not working</li> </ul>	<ul style="list-style-type: none"> <li>- Unlock, clean or in case replace the solenoid valve cartridge or the flow divider</li> </ul>

**\* Operations to be carried out only by authorised installer workshop**

## 10 TECHNICAL DATA - WINCH SPECIFICATIONS

### SERIES 4400 STANDARD EQUIPMENT

- High speed winch with planetary gears reducer
- Remote control with connection and 10 m. - 33' ft. of cable or radio remote control
- Negativ brake for winch
- Proportional monofunction-multifunction hydraulic system
- Load limiting device
- Solenoid valve with manual functions (only for emergency)
- Rotation with worm-gear
- Stop-end system for winch (up and down)

TECHNICAL DATA 4400			
Crane rating		kNm	22
Standard outreach		m	4,80
Slewing angle			400°
Boom elevation			(-5° +80°)
Lifting height from base of crane		m	4.80
Remote control			Proportional
Pump for electrical "E"	12V-24V	l/min	5 - 9
Pump capacity hydraul. "H" (pto)		l/min	10
Working pressure		bar	195
Crane weight		Kg	320
WINCH SPECIFICATION 3304			
Winch pull line		daN	1000
Pull line speed without load	H	m/min	12
	E 12V-24V	m/min	7 -11
Rope diameter		mm	8
Wire rope length		m	30
Cable breaking strength		Kg	minimum 6.050

Technical data not binding

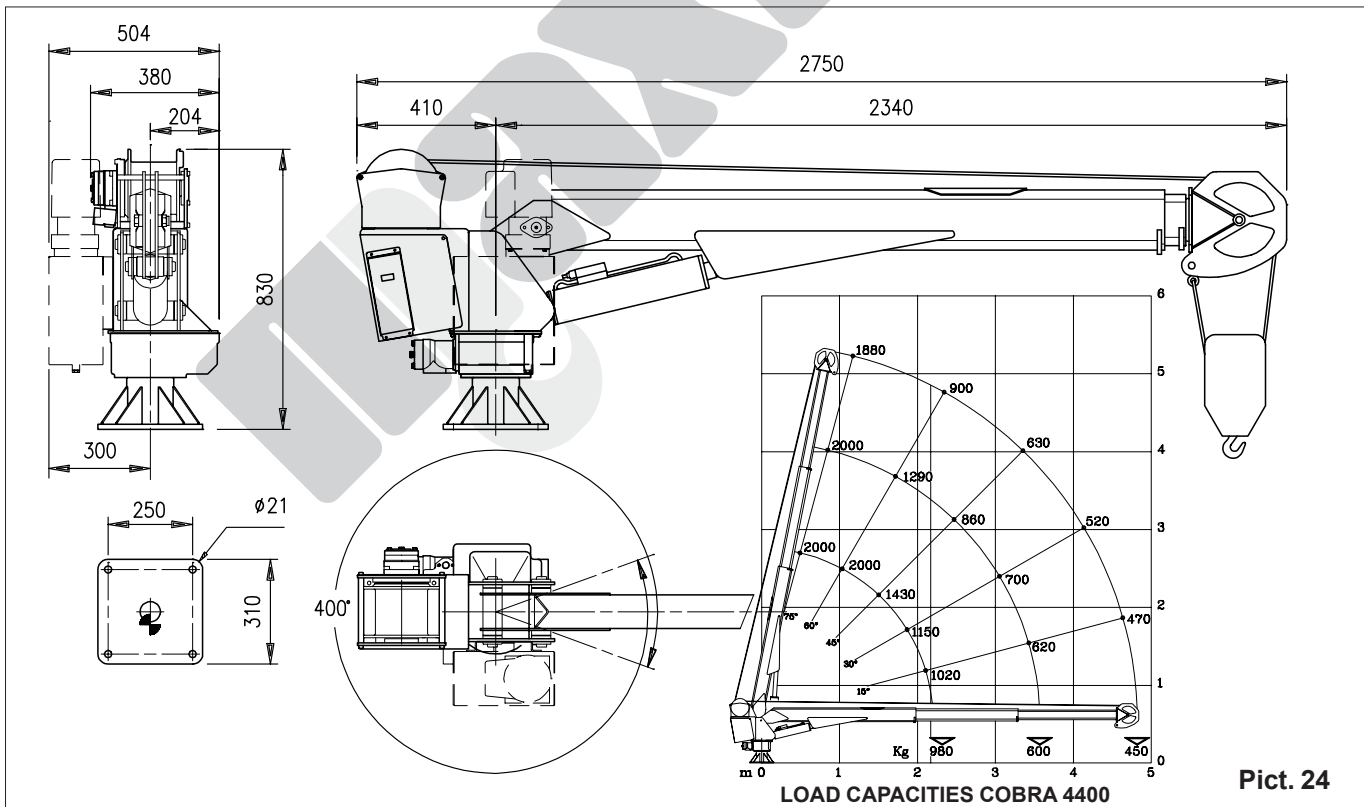

Pict. 24

TECHNICAL DATA 4400			
Crane rating		ft.lbs	16.000
Standard outreach		ft.	15' 8"
Slewing angle			400°
Boom elevation			(-5° +80°)
Lifting height from base of crane		ft.	15' 8"
Remote control			Proportional
Pump for electrical "E"	12V-24V	GPM	1.3 - 2.4
Pump capacity hydraul. "H" (pto)		GPM	2.7
Working pressure		psi	2830
Crane weight		lbs	700
WINCH SPECIFICATION 3304			
Winch pull line		lbs	2.200
Pull line speed	H	ft./min	40
	E 12V-24V	ft./min	23- 37
Rope diameter		inch.	5/16"
Wire rope length		ft.	98
Cable breaking strength		lbs	minimum 13.340

Technical data not binding

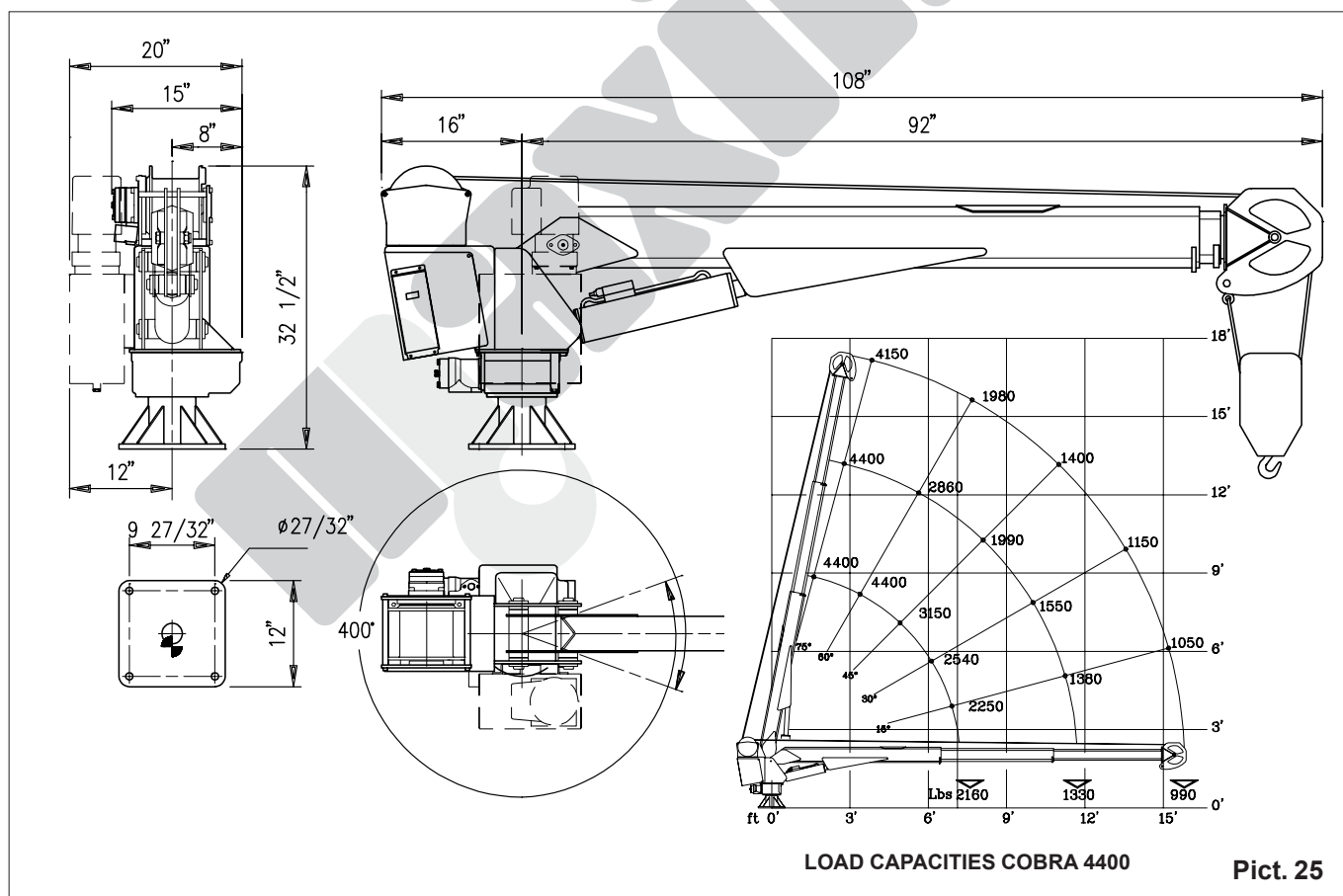

Pict. 25

## 11 WIRING AND HYDRAULIC DIAGRAMS

### 11.1 PENDANT WIRING

- SW1 -Crane rotation selector
- SW2 -Boom movement selector
- SW3 -Extension selector
- SW4 -Winch selector
- SW5 -Engine start/stop selector
- L1 -Green led
- ES -Emergency push button
- 1 -Circuit board
- 2 -Radio remote controle module
- 3 -Proportional trigger button

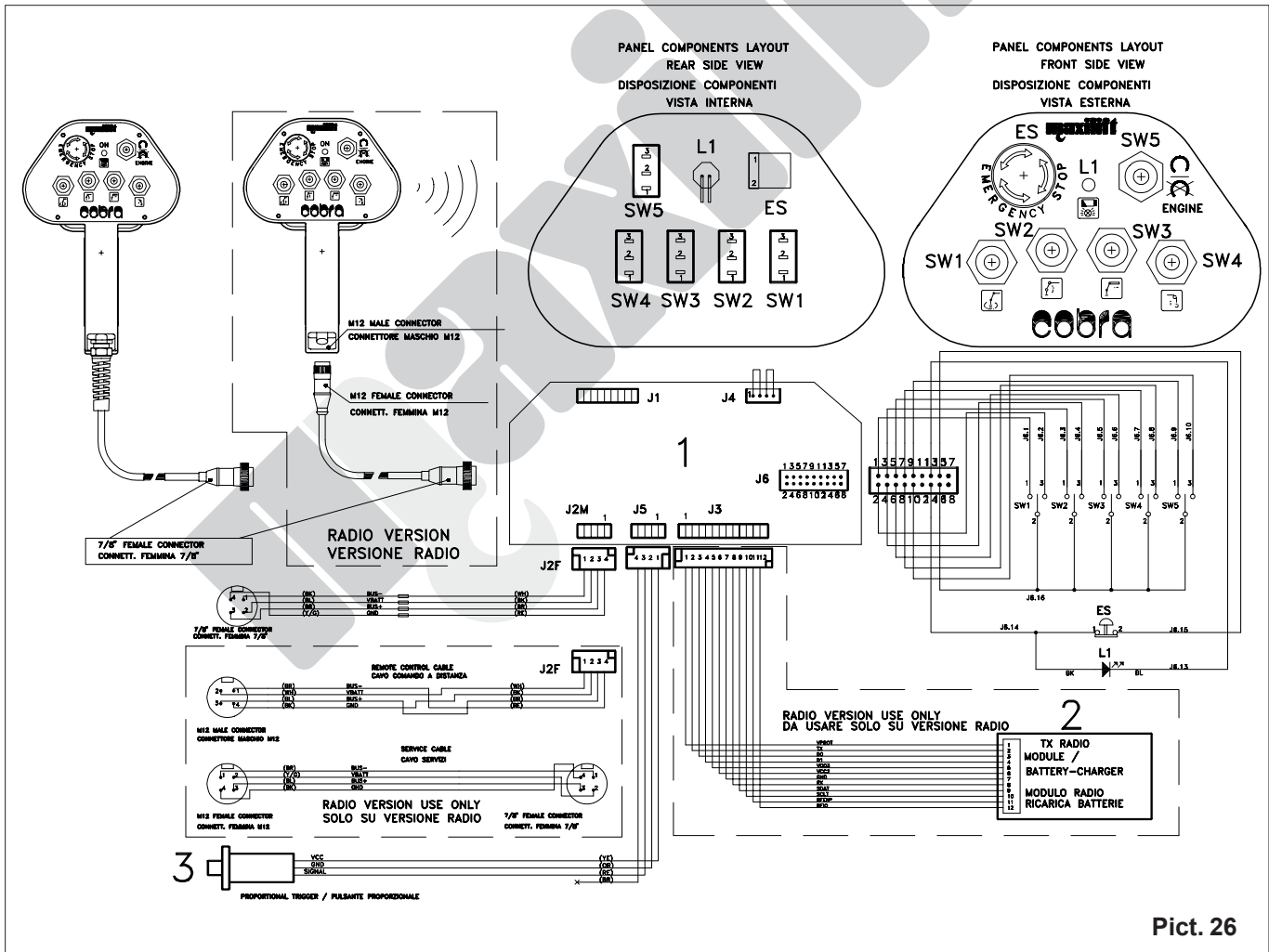

Pict. 26

## 11.2 POWER UNIT AND CONTROL WIRING

- |             |  |             |  |
|-------------|--|-------------|--|
| <b>1</b>    | -Electric swivel                       | <b>2</b>    | -Stop end and supply wiring                  |
| <b>3</b>    | -Circuit board                         | <b>6</b>    | -Radio remote control receiving module       |
| <b>V3</b>   | -Winch electro-valve solenoid          | <b>V4</b>   | -Winch electro-valve solenoid                |
| <b>EV1A</b> | -Clockw. rotation electrov. solenoid   | <b>EV1B</b> | -Counter clockw. rotation electrov. solenoid |
| <b>EV2A</b> | -Boom lifting electro-valve solenoid   | <b>EV2B</b> | -Boom lowering electro-valve solenoid        |
| <b>EV3A</b> | -Extensions electro-valve solenoid     | <b>EV3B</b> | -Extensions re-entry electro-valve solenoid  |
| <b>EV4A</b> | -Winch lowering electro-valve solenoid | <b>EV4B</b> | -Winch raising electro-valve solenoid        |
| <b>FA</b>   | -Winch lowering stop end               | <b>FV</b>   | -Winch raising stop end                      |
| <b>FB</b>   | -Boom lowering stop end                | <b>PM</b>   | -Pressure switch                             |
| <b>VR</b>   | -Proportional electro-valve solenoid   | <b>SC</b>   | -Setting connector                           |
|             |  | <b>V9</b>   | -Safety valve solenoid                       |

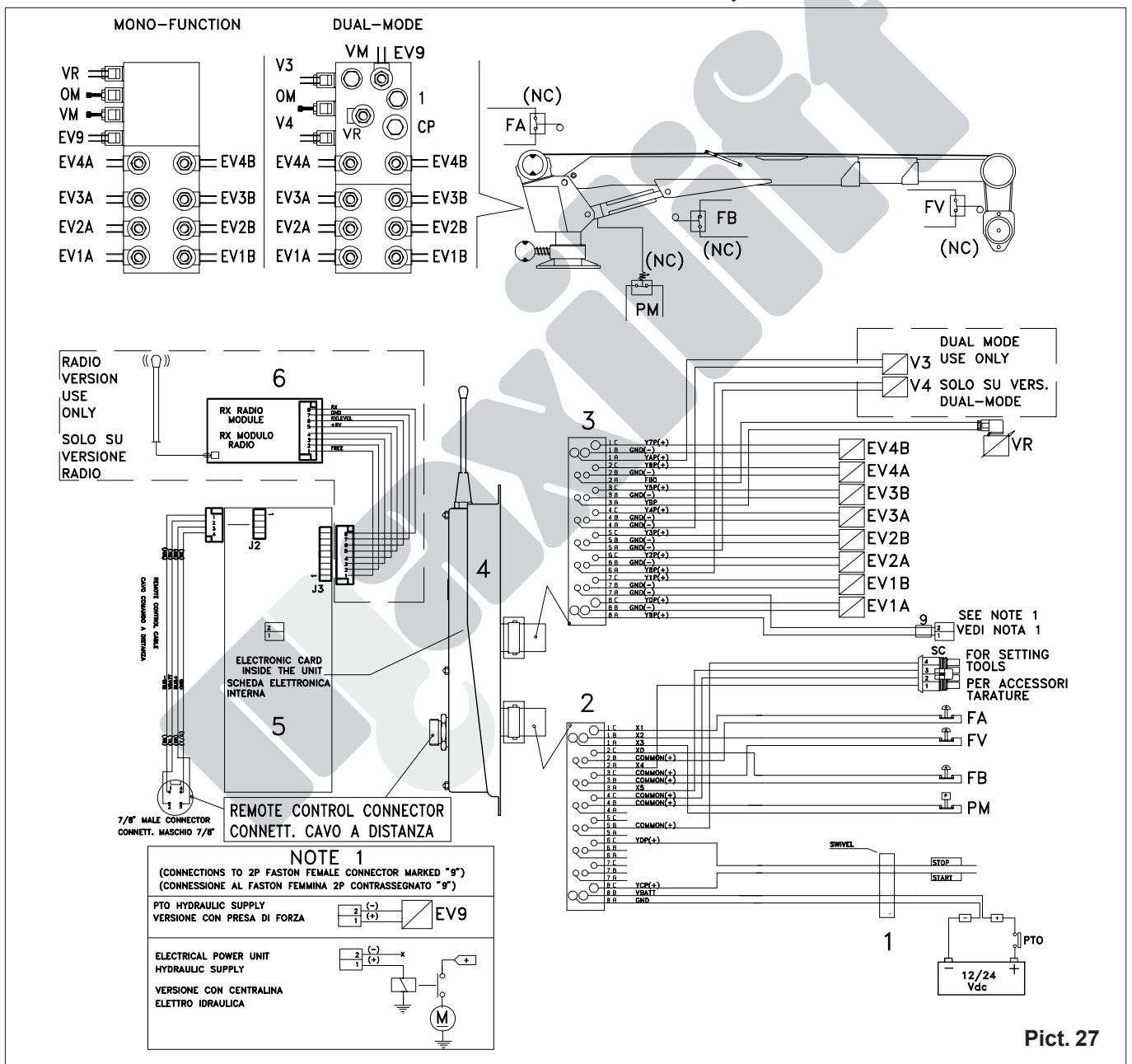

Pict. 27

## 11.3 HYDRAULIC DIAGRAMS

### 11.3.1 Hydraulic diagram mono-function proportional

- 1 Pump
- 2 Electrohydraulic unit
- 3 Rotation motor
- 4 Lifting cylinder
- 5 Overcenter valve
- 6 Pressure switch
- 7
- 8 Extension cylinder
- 9 Overcenter valve
- 10
- 11 Oil filter
- 12 Oil tank
- 13
- 14 Winch motor

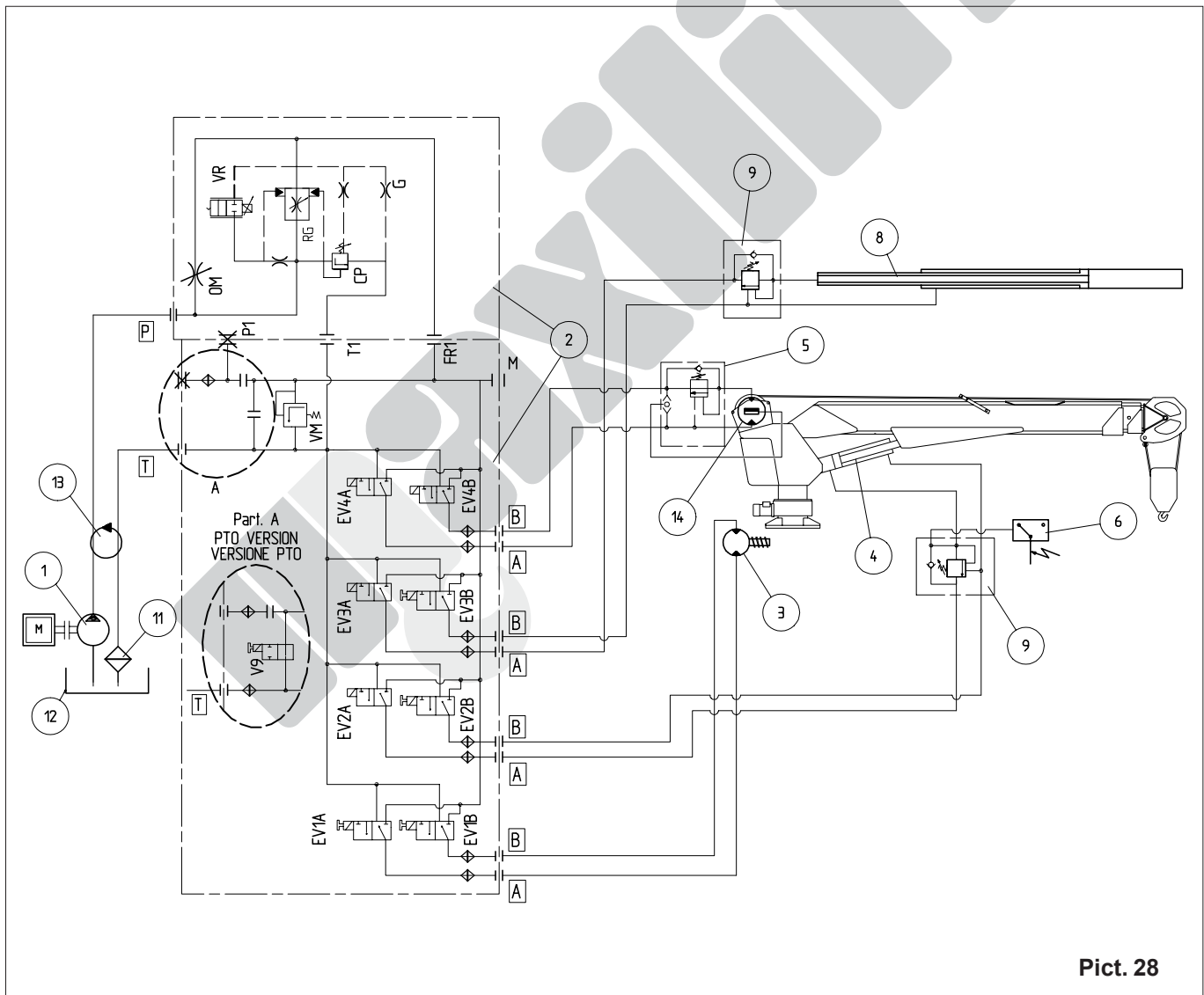

### 11.3.2 Hydraulic diagram dual-mode proportional

- 1 Pump
- 2 Electrohydraulic unit
- 3 Rotation motor
- 4 Lifting cylinder
- 5 Overcenter valve
- 6 Pressure switch
- 7
- 8 Extension cylinder
- 9 Overcenter valve
- 10
- 11 Oil filter
- 12 Oil tank
- 13
- 14 Winch motor

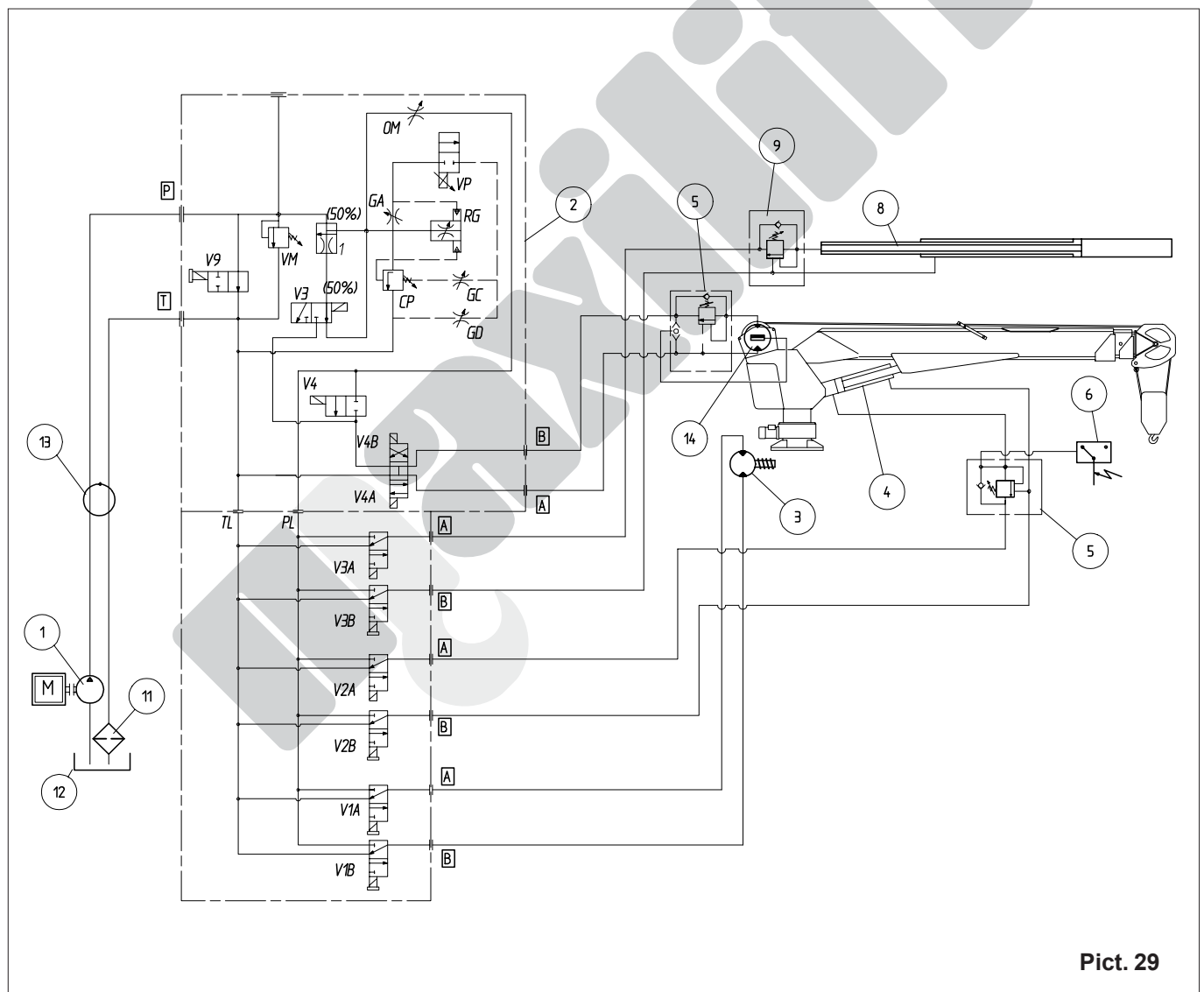

Pict. 29





# **NEXT HYDRAULICS s.r.l.**

Via Mediterraneo, 6  
42022 Boretto (Reggio E.) -Italy  
Tel. 0522/963008 - Fax 0522/963039  
e-mail: [info@maxiliftcrane.com](mailto:info@maxiliftcrane.com)