

VEHICLE INSTALLATION INSTRUCTIONS:  
 CHEV/GMC 4X4: 2011 AND NEWER 2500/3500  
 SILVERADO/SIERRA

Hiniker Company  
 58766 240th St.  
 P.O. Box 3407  
 Mankato, MN 56002

INSTRUCTION SHEET NO: 25012816

August 10, 2010



**IMPORTANT:** Read the Snowplow Operator's Manual before assembling this kit.

MINIMUM VEHICLE RECOMMENDATIONS	REAR BALLAST - 500 lbs. when plow is attached. Secure Weight Behind Rear Wheels.
MFR Snowplow Prep Package	

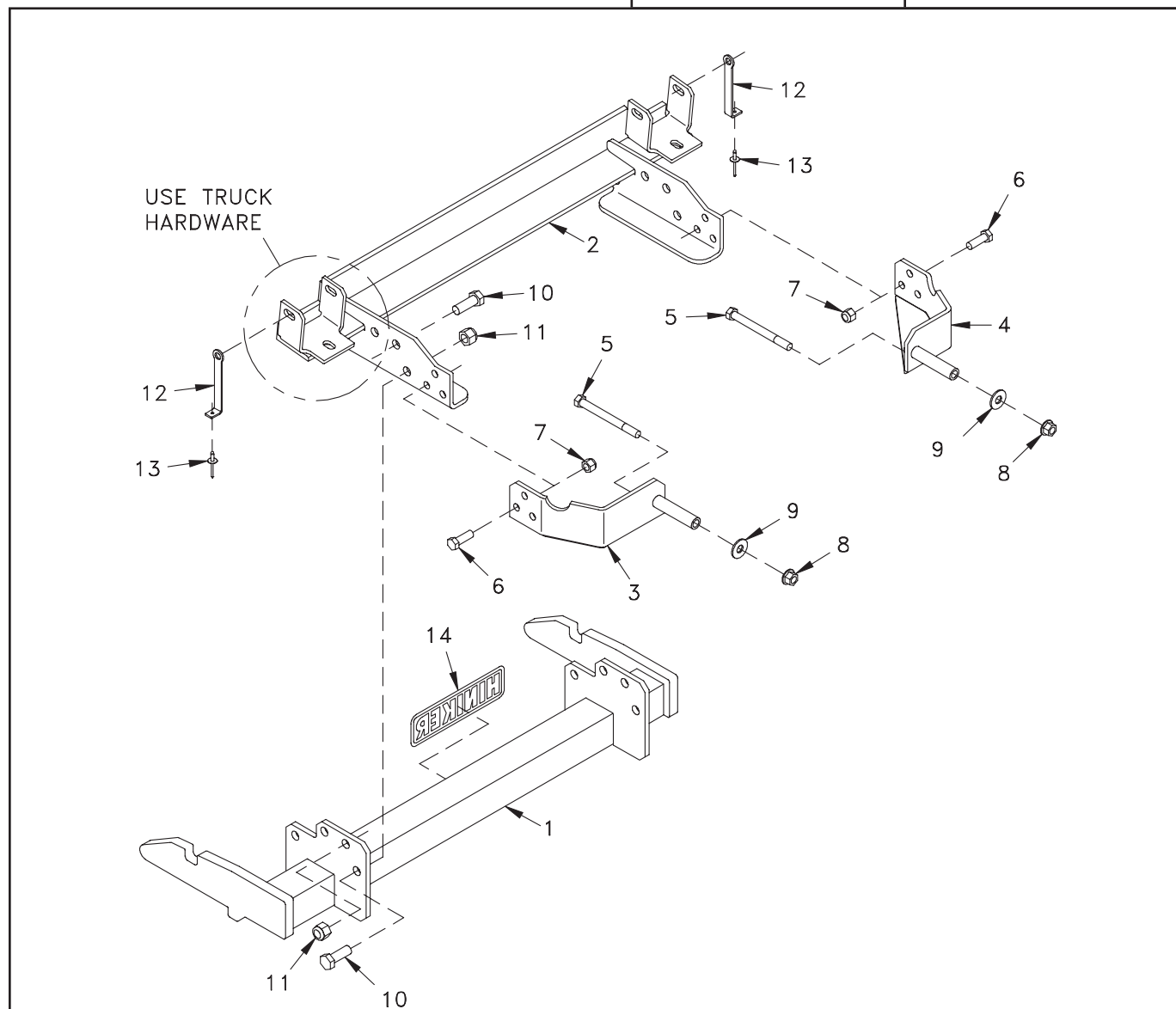

25012815 Mount Kit

DWG. NO. 6631

REF. NO.	PART NUMBER	DESCRIPTION	QTY.	REF. NO.	PART NUMBER	DESCRIPTION	QTY.
1	25011179	Prong Weldment	1	9	952-004-067	Flat Washer 1/2 Inch, Hardened	2
2	25012824	Front Frame Weldment	1	10	950-001-132	Hex Head Cap Screw 5/8-11 x 1 3/4 Gr. 5	8
3	25012817	LH Rear Bracket Weldment	1	11	060756	Lock Nut 5/8-11 Nylon Insert	8
4	25012818	RH Rear Bracket Weldment	1	12	25012218	Fascia Strap	2
5	950-001-271	Hex Head Cap Screw 1/2-13 x 5 1/4 Gr. 8	2	13	954-002-014	Pop Rivet 3/16 x 3/8	2
6	950-001-125	Hex Head Cap Screw 1/2-13 x 1 1/2 Gr. 5	6	14	25010008	Hiniker Decal	1
7	951-003-009	Lock Nut 1/2-13 Nylon Insert	6		25012829	Bolt Bag	
8	951-005-055	Lock Nut 1/2-13 Mac Lock	2				

All hardware should be tightened only enough to ensure safety during assembly. Fully tighten all hardware after entire assembly is completed.

**GRADE 5 TYPE B & F LOCK NUT TORQUE VALUES**

Size	Ft-lbs.	N-m
5/16"	13-18	17-25
3/8"	23-33	31-44
1/2"	58-82	79-112
5/8"	117-165	158-223

**GRADE 5 BOLT TORQUE VALUES\***

Size	Ft-lbs.	N-m
1/4"	8-12	11-16
3/8"	29-41	39-56
1/2"	73-103	99-140
5/8"	146-206	198-279

\* applications without lock nuts

1. Prepare the truck for installation of the mount kit, as follows:
  - Remove the air dam from from below the front bumper by unscrewing the hardware along its length.



PHOTO NO. 1000528A

Return the air dam and unused hardware to the vehicle owner, as these components will not be re-used.

- Remove the two bolts that fasten each tow hook to the truck frame. It is not necessary to remove tow hooks from frame, but be careful that the hooks don't fall and cause injury. Save hardware for kit installation.

- Remove the plastic splash shield from behind the front bumper by unscrewing four bolts and releasing the cooling line clamp above the shield.

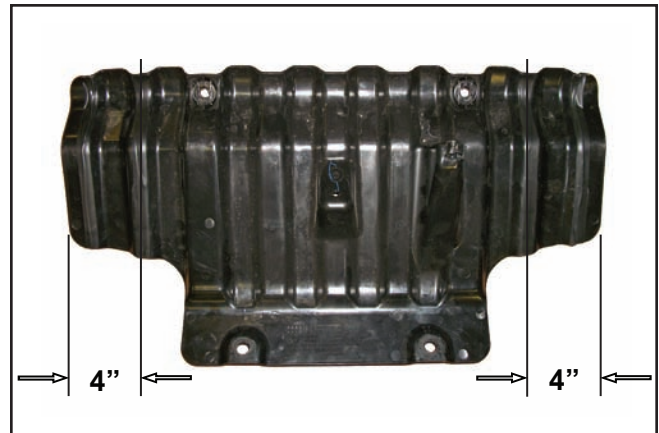

PHOTO NO. 1000504A

Trim approximately 4 inches off both edges of the shield to provide clearance for mount kit brackets.

2. Place a fascia strap from the mount kit bolt bag onto each of the long tow hook bolts, such that the formed leg of the strap is directed opposite from the body of the bolt. These straps will be used to hold up the plastic fascia below the front bumper later in these installations.

Carefully lift the front frame weldment to the vehicle frame so that holes in the front frame match holes in the vehicle frame.

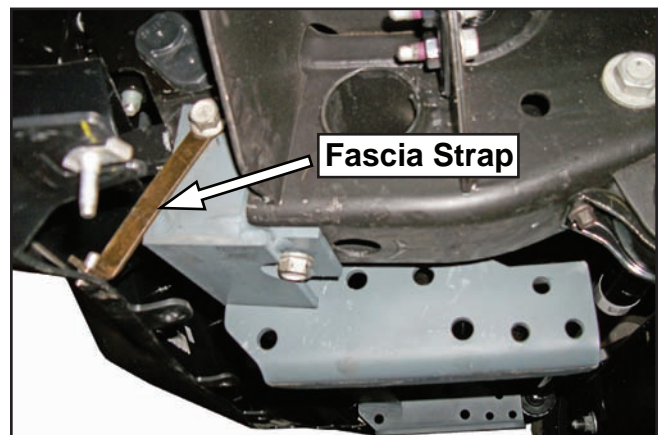

PHOTO NO. 1000523A

Reinstall the tow hook hardware to loosely secure the front frame to the vehicle. Insert the long bolts with fascia straps from the outboard side of the frame members.

3. Identify the LH and RH rear bracket weldments. Insert a 1/2 inch x 5 1/4 inch hex bolt through the spacer bushing of each bracket from the front side of the bracket.

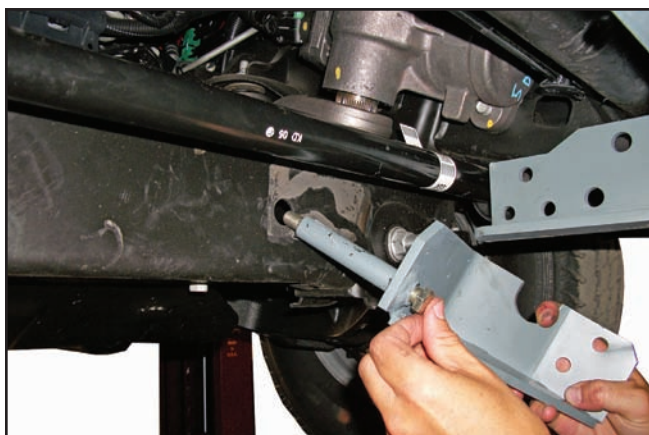

PHOTO NO.1000516

Slip bushings through holes in the vehicle crossmember and loosely secure the brackets with 1/2 inch flat washers and flanged lock nuts from the bolt bag.

Rotate the rear brackets up to the outside of the front frame weldment so that the front holes of rear brackets match rear holes of the front frame.

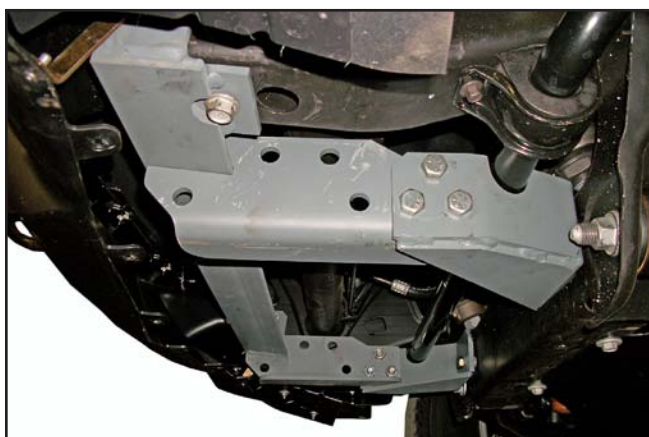

PHOTO NO.1000513

Fasten rear brackets to the front frame with 1/2 inch x 1 1/2 inch hex bolts and nylon insert lock nuts.

4. Fasten the mount plates of the prong weldment to holes in the side bracket of the front frame weldment with eight 5/8" x 1 3/4 inch hex bolts and lock nuts.

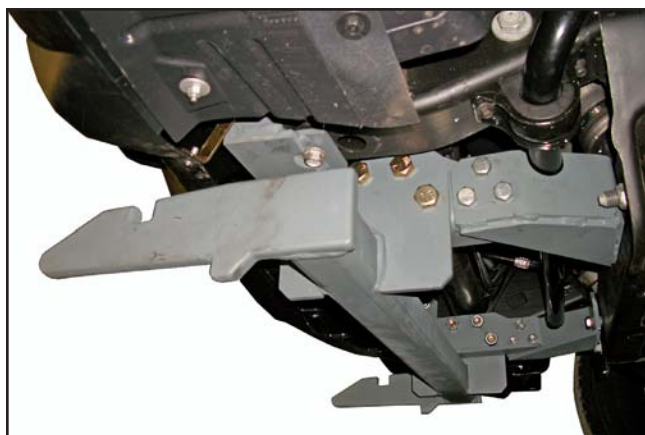

PHOTO NO.1000508

Fully tighten all mount kit fasteners to the specified torque values.

The bottom edge of the prongs should measure about 10 inches above the ground.

5. Use the two fascia straps and pop rivets to secure the plastic bumper fascia away from the snowplow attachment prongs.



PHOTO NO.DCP0910

Push the lower edge of the bumper fascia up to the fascia strap and drill a 3/16 inch diameter hole into the plastic through the hole in the strap.

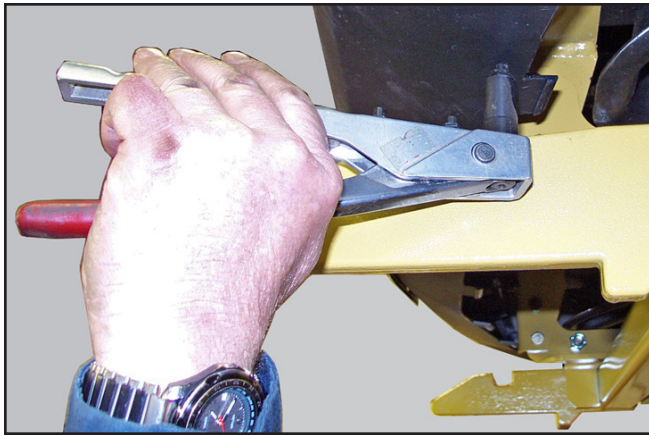

PHOTO NO.DCP0913

Secure the fascia to the straps with the 3/16 inch x 3/8 inch pop rivets from the mount kit bolt bag.

6. Assemble the plastic splash shield removed in step 1 back onto the truck by first reattaching the cooling line clamp above the shield, then fastening the shield to the truck frame with the four original bolts.