

VEHICLE INSTALLATION INSTRUCTIONS FOR:
CHEV/GMC 4x4: 2007 AND NEWER
K1500 SILVERADO/SIERRA

Hiniker Company
58766 240th St.
P.O. Box 3407
Mankato, MN 56002

INSTRUCTION SHEET NO: 25012215

December 4, 2006



IMPORTANT: Read the Snowplow Operator's Manual before assembling this kit.

Minimum Vehicle Recommendations	
MFR Snowplow Prep Package	REAR BALLAST - 500 lbs. when plow is attached. Secure Weight Behind Rear Wheels.

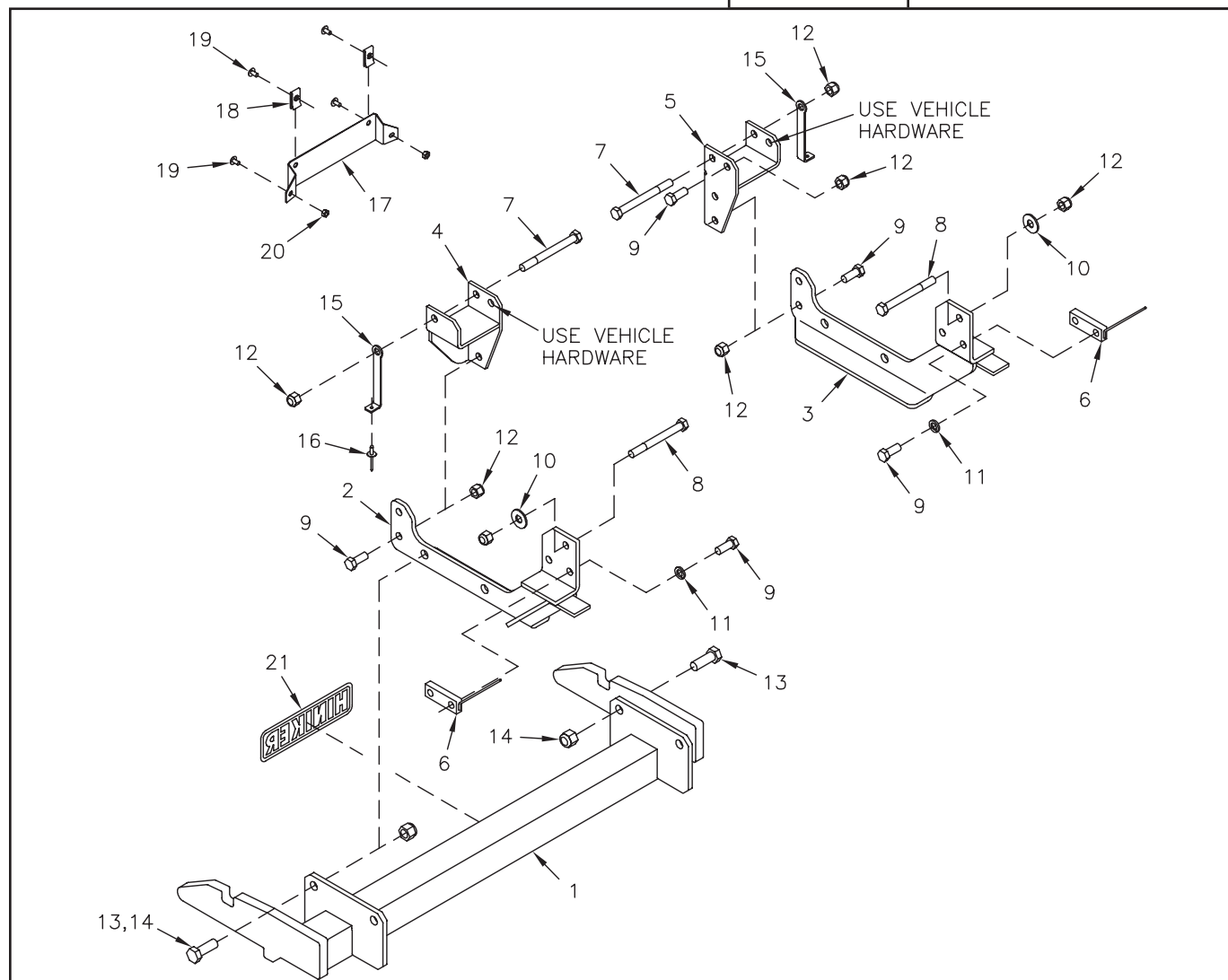

Mount Kit 25012206

DWG. NO. 5947

REF. NO.	PART NUMBER	DESCRIPTION	QTY.	REF. NO.	PART NUMBER	DESCRIPTION	QTY.
1	25012208	Prong Weldment	1	12	951-003-009	Lock Nut 1/2-13 Nylon Insert	9
2	25012209	LH Side Bracket Weldment	1	13	950-001-132	Hex Head Cap Screw 5/8-11 x 1 3/4 Gr. 5	4
3	25012210	RH Side Bracket Weldment	1	14	060756	Lock Nut 5/8-11 Nylon Insert	4
4	25012211	LH Front Bracket Weldment	1	15	25012218	Fascia Strap	2
5	25012212	RH Front Bracket Weldment	1	16	954-002-014	Pop Rivet 3/16 x 3/8	2
6	25012213	Nut Bar Weldment	2	17	25012216	License Plate Bracket	1
7	950-001-325	Hex Head Cap Screw 1/2-13 x 5 Gr. 8	2	18	25012217	Clip Nut 1/4-20	2
8	950-001-284	Hex Head Cap Screw 1/2-13 x 4 3/4 Gr. 5	2	19	950-004-078	Machine Screw 1/4 x 1/2 Slotted Truss Head	4
9	950-001-111	Hex Head Cap Screw 1/2-13 x 1 1/4 Gr. 5	9	20	061278	Lock Nut 1/4-20 Keps	2
10	952-004-067	Flat Washer 1/2 Inch Hardened	2	21	25010008	Hiniker Decal	1
11	952-001-004	Lock Washer 1/2 Inch	4		25012207	Bolt Bag	1

All hardware should be tightened only enough to ensure safety during assembly. Fully tighten all hardware after entire assembly is completed.

GRADE 5 TYPE B & F LOCK NUT TORQUE VALUES

Size	Ft-lbs.	N-m
5/16"	13-18	17-25
3/8"	23-33	31-44
1/2"	58-82	79-112
5/8"	117-165	158-223

GRADE 5 BOLT TORQUE VALUES*

Size	Ft-lbs.	N-m
1/4"	8-12	11-16
3/8"	29-41	39-56
1/2"	73-103	99-140
5/8"	146-206	198-279
* applications without lock nuts		

1. Prepare the truck for installation of the mount kit, as follows:

- Remove the air dam from below the front bumper by first unscrewing a bolt from both ends of the dam, then unsnapping the dam from the lower bumper.



PHOTO NO. DCP0944

Return the air dam and hardware to the vehicle owner, as these components will not be re-used.

- Remove the license plate bracket from the front bumper by unfastening four plastic retainers.

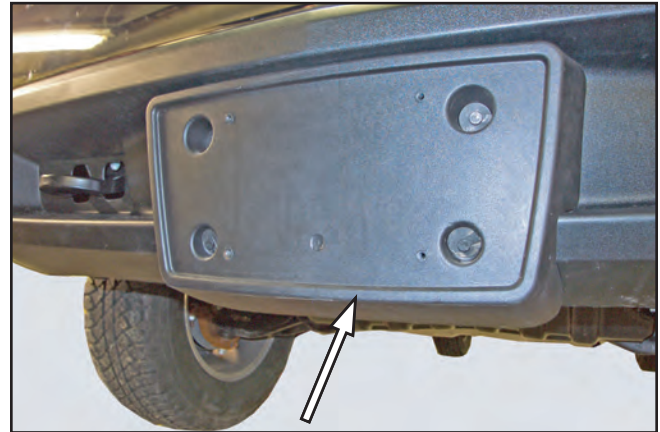

PHOTO NO. DCP0939

Return the bracket and retainers to the vehicle owner, as a new license plate bracket and mounting hardware are provided in the kit.

- Remove the plastic splash shield from behind the front bumper by unscrewing four bolts.

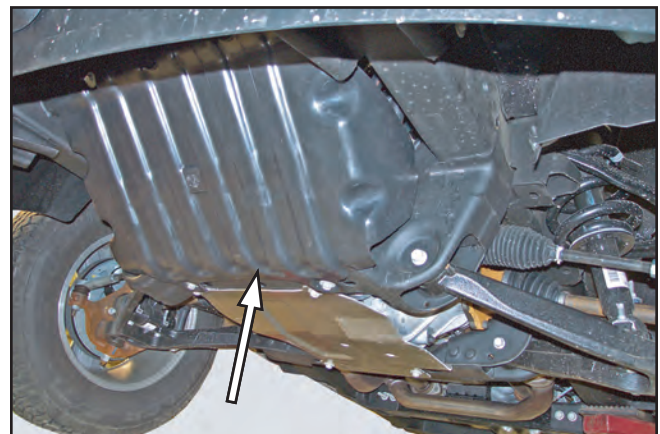

PHOTO NO. DCP0945

Set aside the shield and fasteners for reinstallation later.

- Remove both tow hooks from the vehicle by unscrewing two bolts per hook. Set aside the tow hooks and short bolts for reinstallation. The long bolts and nuts will be replaced by hardware supplied in the kit.

- Identify the LH and RH front bracket weldments by referring to the front page illustration.

On the passenger side of the truck, leave the tow hook removed while bolting the RH front bracket to the vehicle frame with the original short bolt in the rear hole and a 1/2 inch x 5 inch hex bolt from the kit through the front holes. Push the bracket up tight to the frame, then drill a 1/2 inch diameter hole into the frame through the rear inner hole of the bracket.



PHOTO NO. DCP0926

Insert a 1/2 inch x 1 1/4 inch hex bolt into the drilled hole before removing the front bolt. Install a 1/2 inch lock nut onto the bolt and fully tighten to hold the bracket in place.

Set the tow hook into the frame rail in the same position from which it was removed and reinstall the original short bolt into the outer rear hole.

Insert a 1/2 inch x 5 inch hex bolt through the front holes of the bracket and tow hook from the inboard side of the frame rail. Slip a fascia strap from the kit onto the end of the bolt, then loosely secure the assembly with a lock nut.



PHOTO NO. DCP0930

On the driver side of the truck, set the tow hook into the frame rail in its original position and reinstall the original short bolt into the inner rear hole.

Insert the a 1/2 inch x 5 inch hex bolt through the front holes of the bracket and tow hook from the inboard side of the frame rail. Slip a fascia strap onto the end of the bolt and secure the assembly with a lock nut.

- Bolt the LH and RH side bracket weldments to the outside faces of the front bracket weldments, using two 1/2 inch x 1 1/4 inch hex bolts and lock nuts per side.

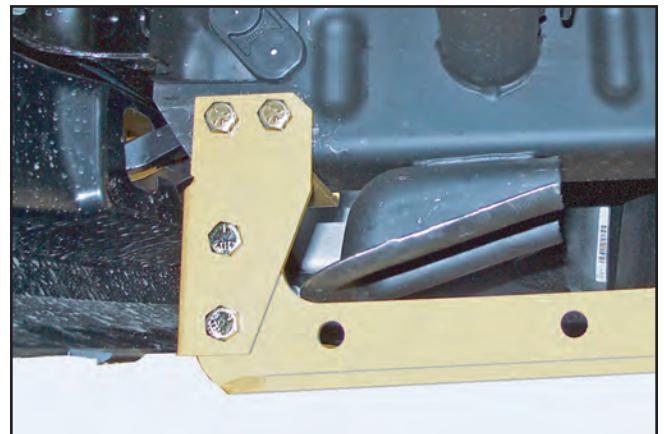

PHOTO NO. DCP0921

At the back of each side bracket, insert a 1/2 inch x 4 3/4 inch hex bolt through the upper hole in the plate and through both walls of the vehicle frame rail. Install a 1/2 inch flat washer and lock nut onto each bolt end to hold the brackets up.



PHOTO NO. DCP0923

Drill two 1/2 inch diameter holes into the inner wall of both frame rails through holes in the bracket plates.

Bend handles on the nut bar weldments, as required, and insert bars into slots through the outer walls of the frame rails to match drilled holes in the inner walls.



PHOTO NO. DCP0927

Place a lock nut onto four remaining 1/2 inch x 1 1/4 inch hex bolts, then thread bolts into the two nut bars to finish installation of the side brackets.

4. Fasten the mount plates of the prong weldment to holes in the LH and RH rear bracket weldments with four 5/8 inch x 1 3/4 inch hex bolts and lock nuts.



PHOTO NO. DCP0905

The bottom edges of the prongs should measure about 10 inches above the ground.

5. Use the two fascia straps and pop rivets to secure the plastic bumper fascia away from the snowplow attachment prongs.



PHOTO NO. DCP0910

Push the lower edge of the bumper fascia up to the fascia strap and drill a 3/16 inch diameter hole into the plastic through the hole in the strap.

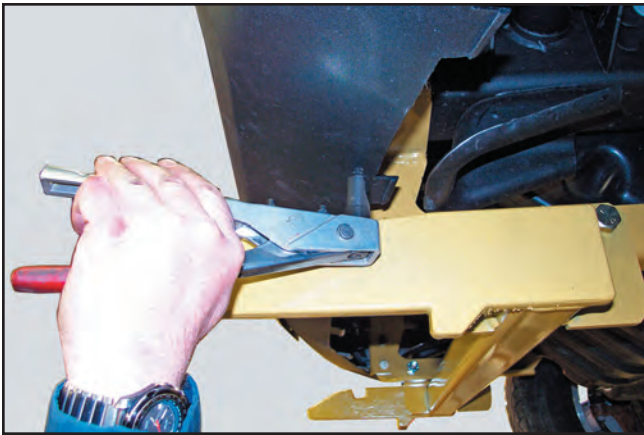

PHOTO NO. DCP0913

Secure the fascia to the straps with the 3/16 inch x 3/8 inch pop rivets from the mount kit bolt bag.

6. Assemble the plastic splash shield that was removed in step 1 back onto the truck using the original four fasteners.

Fully tighten all mount kit fasteners to the specified torque values.

7. Fasten the license plate bracket from the kit to the upper set of holes from where the original bracket was removed, using two 1/4 inch x 1/2 inch machine screws and lock nuts. Attach the bracket so that clip nuts are along the top edge of the bracket.



PHOTO NO. DCP0935

Use the two remaining screws to attach the license plate to the bracket.