

Hiniker Company
 58766 240th St.
 P.O. Box 3407
 Mankato, MN 56002

INSTRUCTION SHEET FOR:
 DODGE DAKOTA 4X4: 2005 - NEWER

INSTRUCTION SHEET NO: 25011958

August 25, 2005



IMPORTANT: Read the Snowplow Operator's Manual before assembling this kit.

REAR BALLAST -
 150 lbs. when plow is attached.
 Secure Weight Behind Rear
 Wheels.

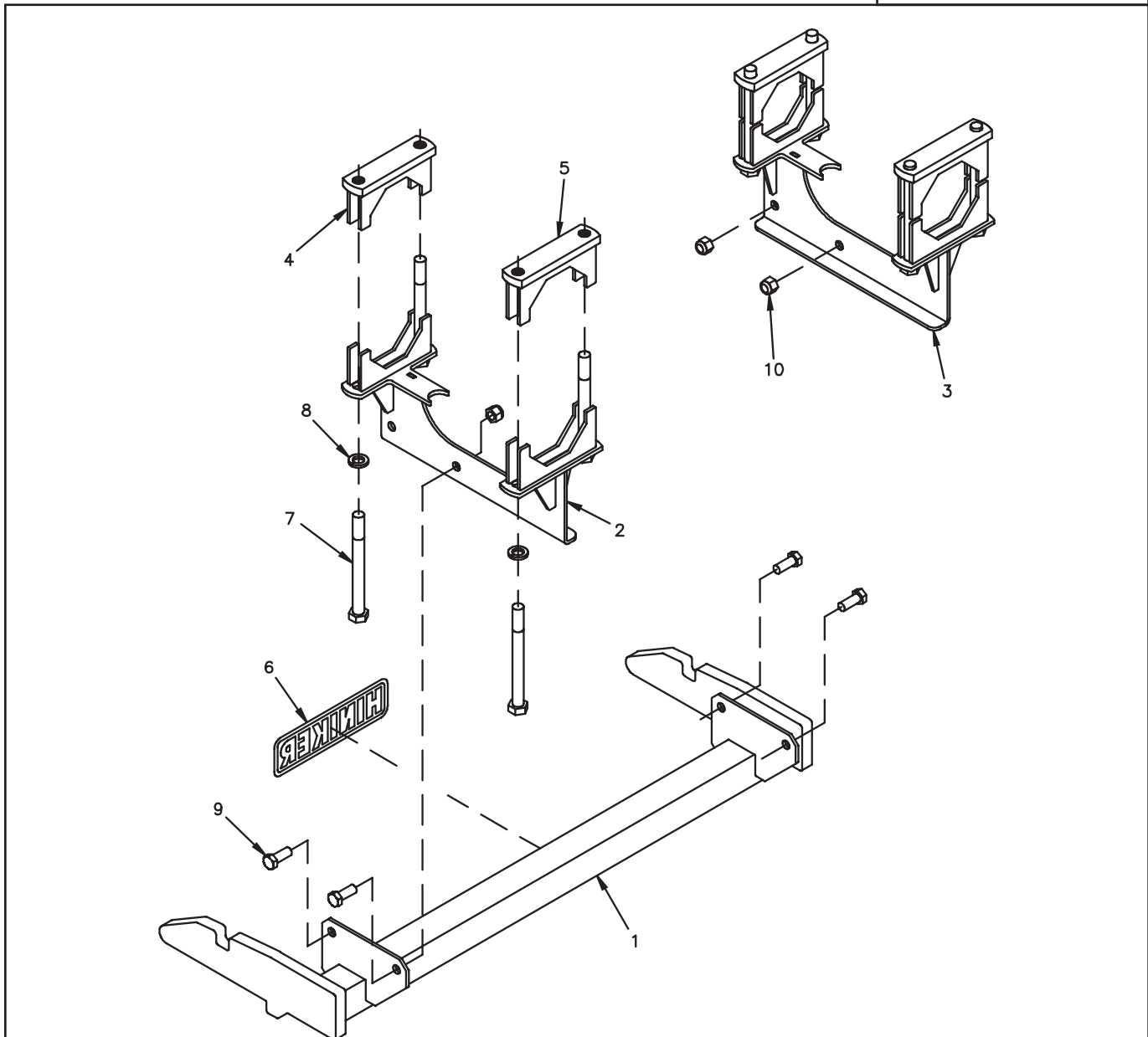

25011817 Mount Kit

DWG NO. 5743

REF. NO.	PART NUMBER	DESCRIPTION	QTY.	REF. NO.	PART NUMBER	DESCRIPTION	QTY.
1	25011953	Prong Weldment	1	7	950-001-027	Hex Head Cap Screw 5/8-11 x 6 1/2 Gr. 5	8
2	25011954	LH Bracket Weldment	1	8	952-001-005	Lock Washer, 5/8 Inch	8
3	25011955	RH Bracket Weldment	1	9	950-001-111	Hex Head Cap Screw 1/2-13 x 1 1/4 Gr. 5	4
4	25011956	Front Clamp Weldment	2	10	951-003-009	Lock Nut 1/2-13 Nylon Insert	4
5	25011957	Rear Clamp Weldment	2		25011959	Bolt Bag	1
6	25010008	Hiniker Decal	1				

All hardware should be tightened only enough to ensure safety during assembly. Fully tighten all hardware after entire assembly is completed.

GRADE 5 TYPE B & F LOCK NUT TORQUES

Size	Ft-lbs.	N-m
5/16"	13-18	17-25
3/8"	23-33	31-44
1/2"	58-82	79-112
5/8"	117-165	158-223

GRADE 5 BOLT TORQUES*

Size	Ft-lbs.	N-m
1/4"	8-12	11-16
3/8"	29-41	39-56
1/2"	73-103	99-140
5/8"	146-206	198-279

* applications without lock nuts

1. Identify the front and rear upper clamp halves. Front clamps have a narrower gap than rear clamps.

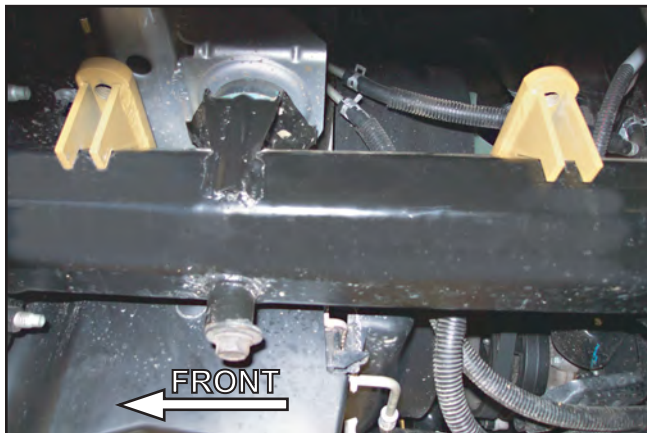
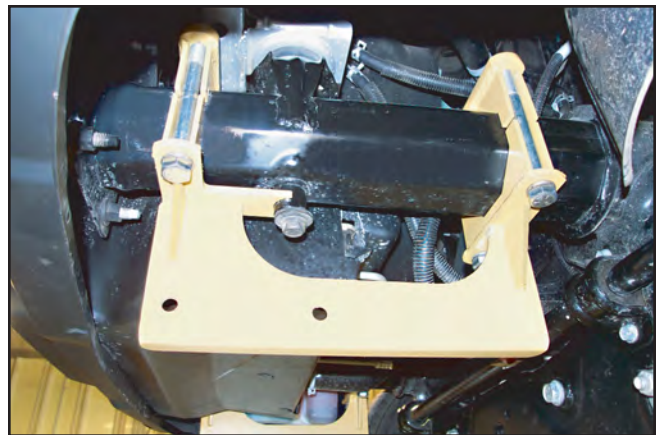

PHOTO NO. 9670

Place the clamp halves on top of the vehicle frame rails on both sides of the truck in the approximate locations shown in the photo.

2. Lift the LH and RH bracket weldments to the bottom of the corresponding frame rail. Push each bracket tight against the protruding stud from the bottom of the frame rail before loosely threading four 5/8 inch x 6 1/2 inch hex bolts into the upper clamp halves.



Driver Side

PHOTO NO. 9664



Passenger Side

PHOTO NO. 9662

Alternate tightening bolts from one side of the rail to the other to draw the upper and lower clamp halves together evenly.

3. Fasten the mount plates of the prong weldment to holes in the LH and RH brackets with four 1/2 inch x 1 1/4 inch hex bolts and lock nuts.



PHOTO NO. 9659

Bottom edges of the pronges should measure about 10 inches above the ground when completed.

Fully tighten hardware to specified torque values.

Headlight Removal

The following instructions are reprinted from the 2005 Dodge Dakota owner's manual. Follow these instructions when installing the mount kit headlight adapters.

1. Open the hood.
2. Remove the three (3) screws attaching the headlamp housing to the inner panel.

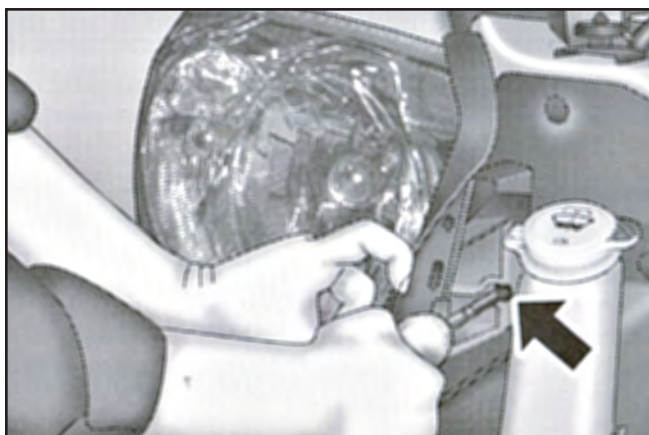

Removing Attaching Screw

3. Grasp the headlamp and pull firmly to disengage the headlamp housing from the fender panel.

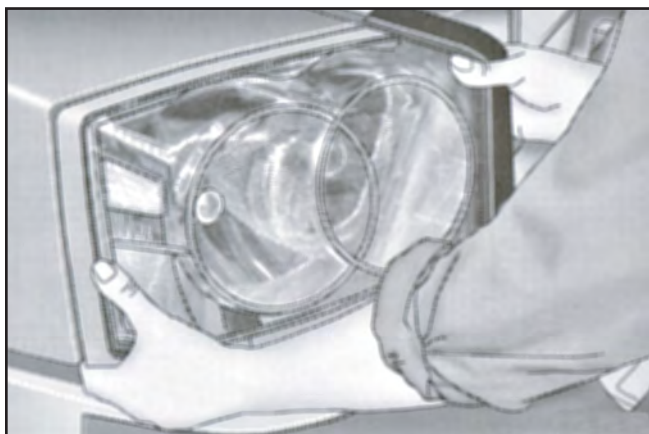

Removing Headlamp Assembly

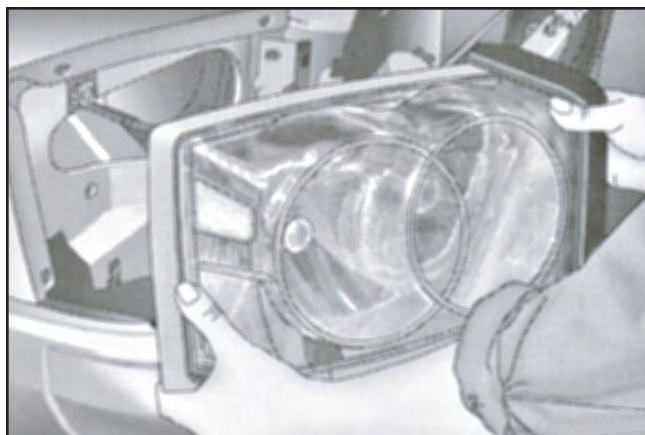

Removing Headlamp Assembly