

VEHICLE INSTALLATION INSTRUCTIONS
 FORD 4x4: 2005-2007 SUPER DUTY
 F250-350-450-550

Hiniker Company
 58766 240th St.
 P.O. BOX 3407
 Mankato, MN 56002

INSTRUCTION SHEET NO: 25011740 Rev. A

April 27, 2007



IMPORTANT: Read The Snowplow Operators Manual Before Assembling This Kit.

Minimum Vehicle Recommendations	
MFR. Snowplow Prep Package	Rear Ballast-500 lbs. When Plow Is Attached. Secure Weight Behind Rear Wheels

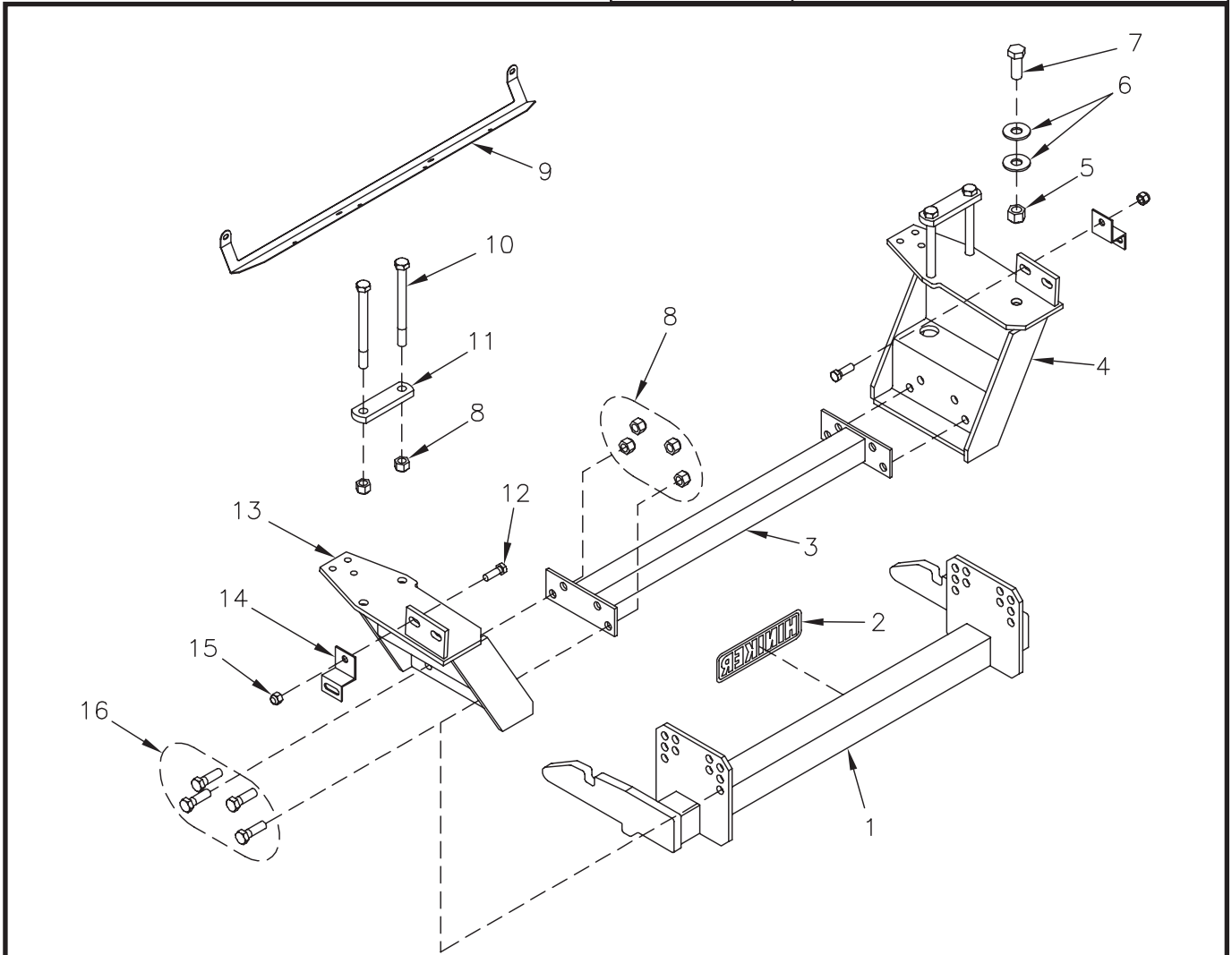

MOUNT KIT NO. 25011732

DWG NO. 5477

REF. NO.	PART NUMBER	DESCRIPTION	QTY.	REF. NO.	PART NUMBER	DESCRIPTION	QTY.
1	25011733	Prong Weldment	1	9	25011739	Trim Retainer Strap	1
2	25010008	Hiniker Decal	1	10	950-001-143	Hex Head Cap Screw 5/8-11 x 7 Gr 5	4
3	25011737	Cross Tube Weldment	1	11	25011736	Top Bar	2
4	25011735	RH Bracket Weldment	1	12	950-001-125	Hex Head Cap Screw 1/2-13 x 1-1/2 Gr 5	2
5	951-003-010	Lock Nut, 3/4 Nylon Insert	2	13	25011734	LH Bracket Weldment	1
6	10449	Flat Washer, 3/4 Inch, Hardened	4	14	25011738	Bumper Retainer	2
7	950-001-166	Hex Head Cap Screw 3/4-10 x 2 Gr 5	2	15	951-003-009	Lock Nut, 1/2 Nylon Insert	2
8	060756	Lock Nut, 5/8 Nylon Insert	12	16	950-001-023	Hex Head Cap Screw 5/8-11 x 2 Gr 5	8
					25011749	Bolt Bag	1

All hardware should be tightened only enough to ensure safety during assembly. Fully tighten all hardware after entire assembly is completed.

GRADE 5 TYPE B & F LOCK NUT TORQUES

Size	Ft-lbs.	N-m
5/16"	13-18	17-25
3/8"	23-33	31-44
1/2"	58-82	79-112
5/8"	117-165	158-223

GRADE 5 BOLT TORQUES*

Size	Ft-lbs.	N-m
1/4"	8-12	11-16
3/8"	29-41	39-56
1/2"	73-103	99-140
5/8"	146-206	198-279

*Applications without lock nuts.

1. Remove the front bumper from the truck by first detaching four plastic trim panel retainers from the blocker beam crossmember and disconnecting the engine block heater cord and fog light connectors, if equipped. Trim panel retainers will be reinstalled later. Unbolt six fasteners to remove the bumper from the vehicle. Save the hardware for re-installation.

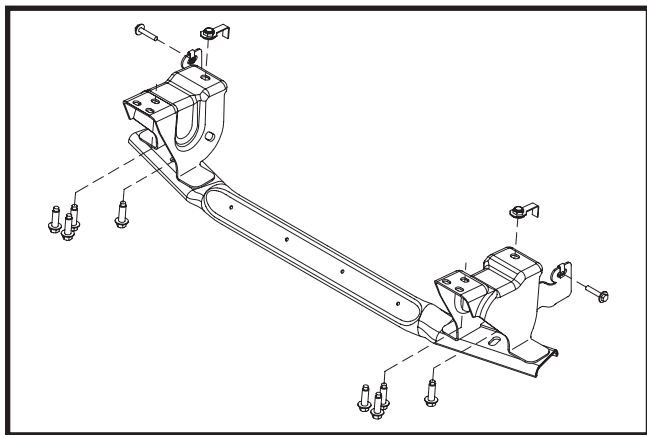

DWG NO. 5479

Remove the blocker beam assembly from the truck by first unbolting the rear bolt from each side, then removing the three front bolts threaded into each tow hook. Save the tow hooks and six tow hook bolts for re-installation.

The blocker beam assembly should be packaged and supplied to the customer, along with reassembly instructions, so the truck can be returned to its original configuration if the snowplow kit is removed in the future.

2. Install two 5/8 inch x 7 inch hex bolts through holes in top bars, item 1 in photo 8315, and place bars over top of each frame rail at the location shown.

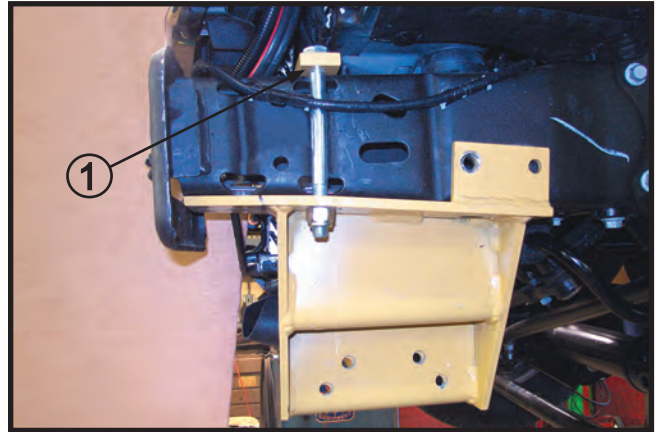

PHOTO NO. 8315

Lift the LH and RH bracket weldments to the bottom of the vehicle rails and install 5/8 inch lock nuts onto bolts to hold the brackets in place.

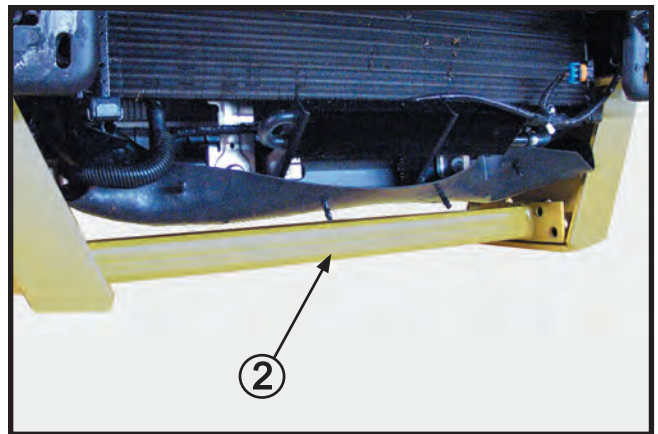

PHOTO NO. 8317

Set the cross tube weldment, item 2 in photo 8317, so that holes in the end plates will match holes in brackets when the prong weldment is installed later.

3. Place two 3/4 inch flat washers onto each 3/4 inch x 2 inch hex bolt, then install bolts from inside vehicle rails through the rear hole in the brackets, as shown at location 3 in photo 8312.

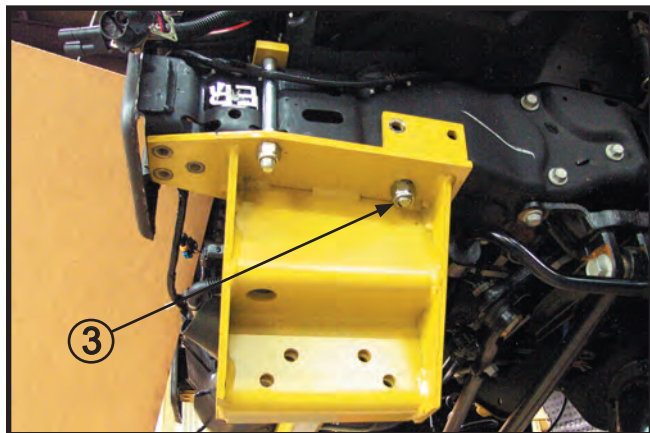

PHOTO NO. 8312

Thread a 3/4 inch lock nut onto each bolt to secure the assembly.

4. On each side of the vehicle, insert a 1/2 inch x 1-1/2 inch hex bolt through holes in the frame and side bracket at location 4 in photo 8307.

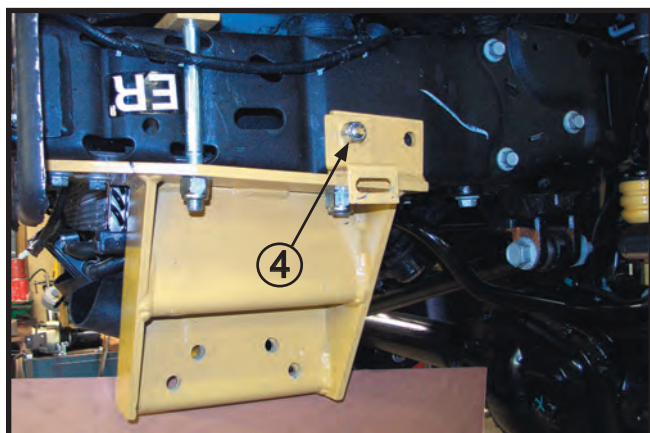

PHOTO NO. 8307

Place a bumper retainer onto the bolt and loosely secure the assembly with a 5/8 inch lock nut.

5. Reassemble the tow hooks to the vehicle through holes in the mount brackets, using the six bolts removed earlier.



PHOTO NO. 8308

6. Fasten the mount plates of the prong weldment to holes in the mount brackets and cross tube weldment with eight 5/8 inch x 2 inch hex bolts and lock nuts.

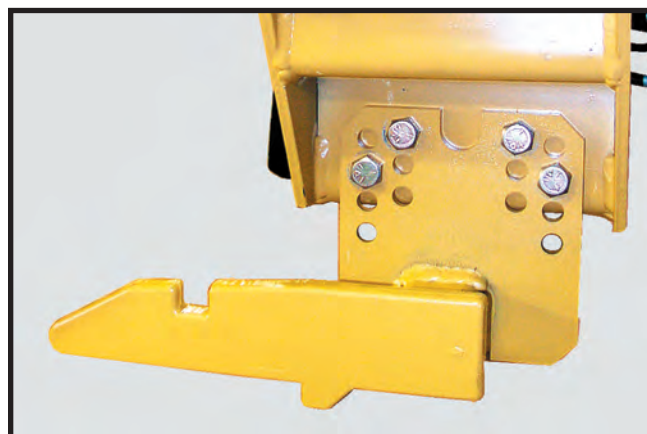

PHOTO NO. 8296

Bottom edges of the prongs should measure about 10 inches above the ground. Ideally, the prongs should lift the plow frame slightly when driving into the plow.

- Remove two bolts from the inside lower edge of the bumper, shown at location 5 in photo 8303, and install the trim retainer strap.

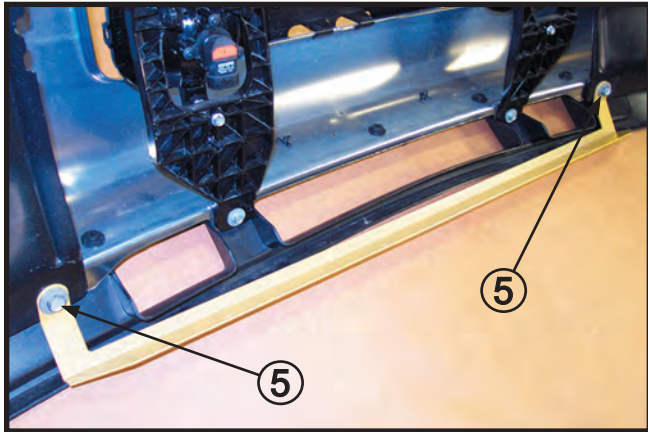

PHOTO NO. 8303

- Complete installation of the underhood wiring harness and power cable assembly while the front bumper is removed from the truck. Refer to the snowplow operators manual for assembly instructions.

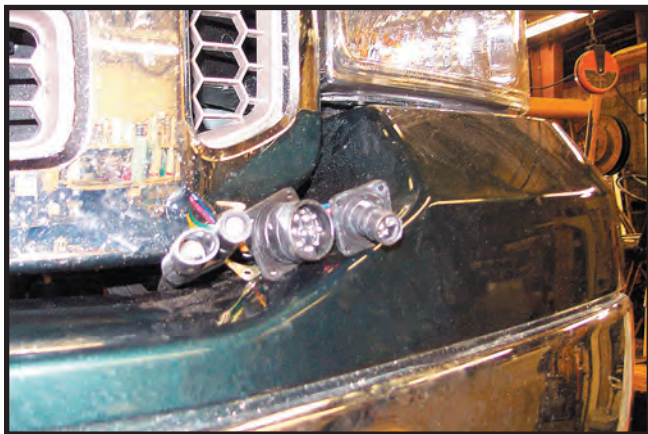
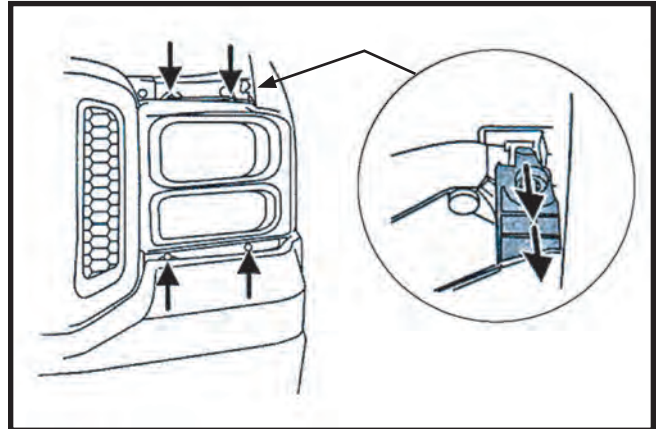

PHOTO NO. 8295

Wiring connector ends should be routed so they pass between the bumper and grill, as shown in photo 8295, after the bumper is reinstalled in step 9.

The following instructions are reprinted from the 2005 Ford Super Duty owners manual. Follow these instructions when installing the mount kit headlight adapters.

- Make sure that the headlamp control is in the OFF position and open the hood.
- Remove the four screws from the top and bottom front of the headlamp assembly.



DWG NO. 5480

- Press the retaining clip at the top of the headlamp assembly while pulling the assembly straight out.

If removing the lamp is difficult, removing the four screws along the top of the grill will help provide more clearance.

- Disconnect the electrical connector by squeezing the release tab and pushing the connector forward and then pulling it rearward.

9. Begin reinstallation of the front bumper by placing clip nuts from the blocker beam assembly onto bumper retainers, as shown in photo 8298.

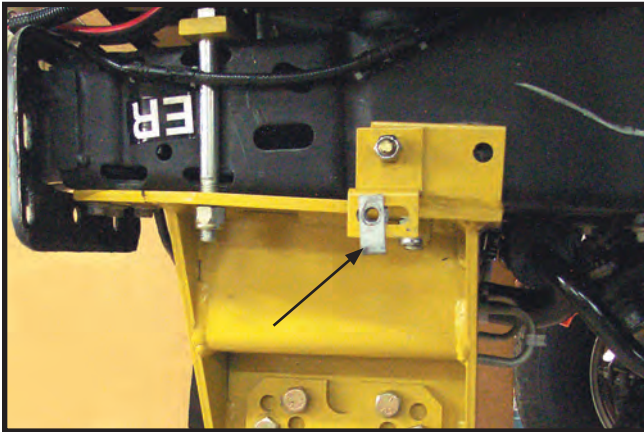

PHOTO NO. 8298

Carefully lift the bumper into position on the truck and reattach using original fasteners.

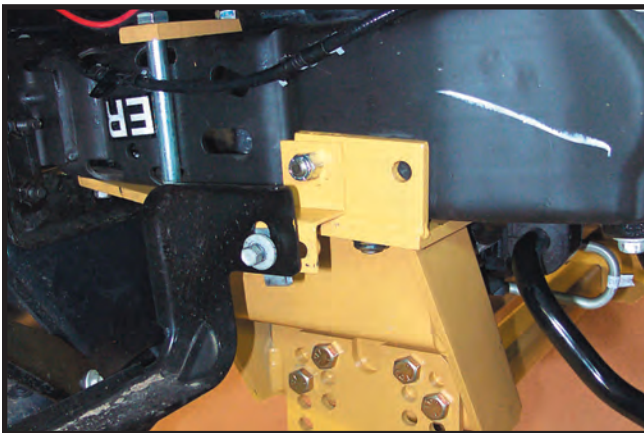

PHOTO NO. 8291

Reconnect fog lights and engine block heater cord between the truck and the bumper.

Reach through bottom openings in the bumper to push plastic trim panel retainers into holes in the trim panel retainer strap, as shown in photo 8284.

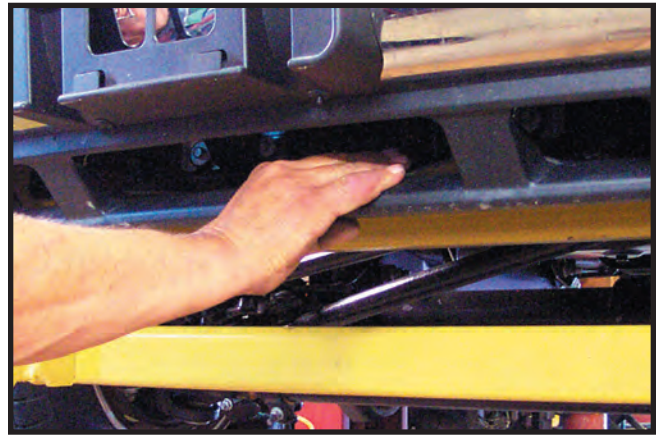

PHOTO NO. 8284

10. Finally tighten all hardware to specified torques.