

maxilift



H2-B3

Cod.: MP.0.159 US
Rev.: 0



Next Hydraulics®



DIMENSIONI - DIMENSIONS

GRU - CRANE	A	B	C	D	E	F
500.2C	72"	50 1/2"	18"	4 1/2"	17"	61 1/2"
500.3C	72"	50 1/2"	16 1/2"	6"	17"	61 1/2"
500.2L	71"	57 1/2"	11"	4 1/2"	16 1/2"	63"
500.3L	71"	57 1/2"	9"	6 1/2"	16 1/2"	63"

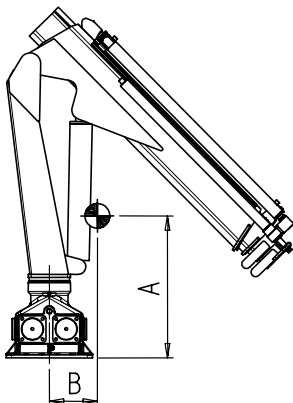
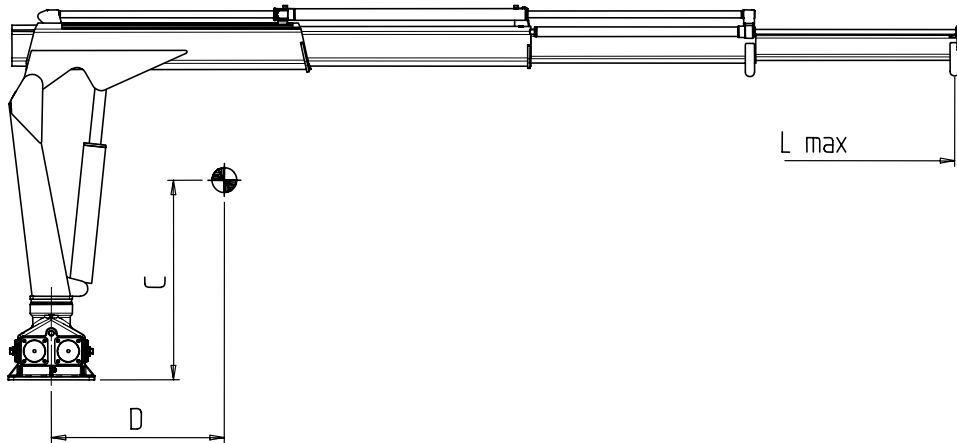
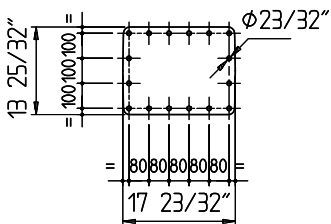
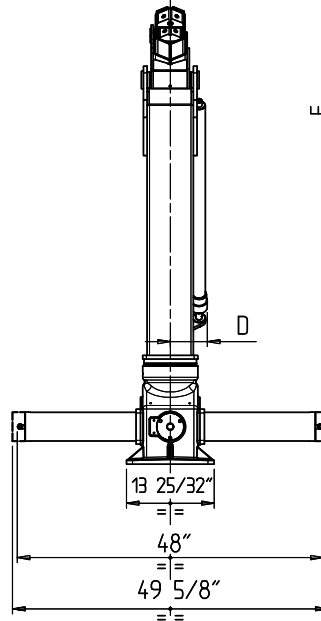
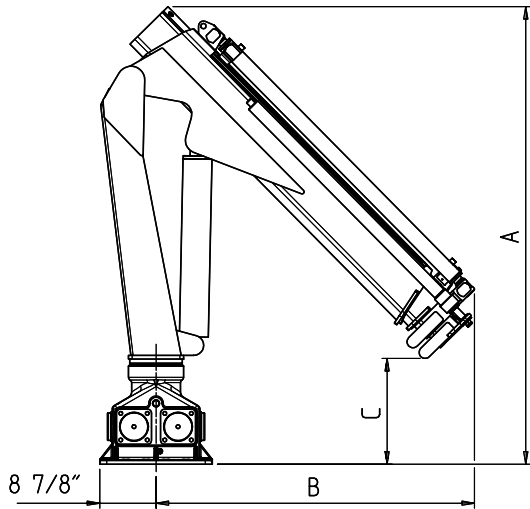
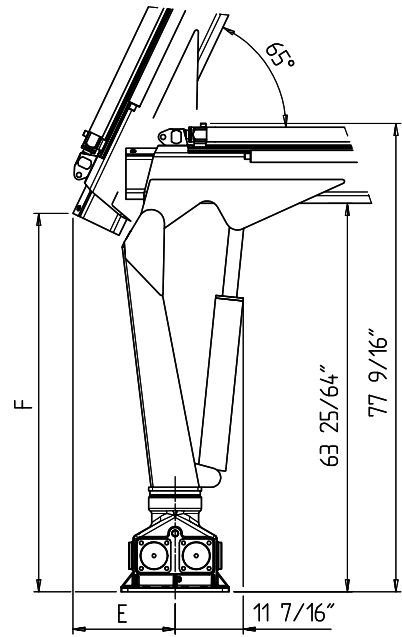

GRU - CRANE	A	B	C	D	L max
500.2C	28 1/2"	8 1/2"	39"	26"	144"
500.3C	29"	10"	41"	35 1/2"	185"
500.2L	27"	11"	40"	33"	173"
500.3L	27 1/2"	13"	42"	46 1/2"	226"

TECHNICAL DATA		VERSION			
TYPE	500	500.2C	500.3C	500.2L	500.3L
CRANE RATING	ft lbs	35403			
STANDARD EXTENSIONS Nr (HYDRAULICS)	N°	2	3	2	3
STANDARD OUTREACH	ft	12'	15' 5"	14' 15"	18' 10"
SLEWING ANGLE	°	360°			
MAXIMUM ANGLE SLOPE	°	15°			
SLEWING TORQUE	ft lbs	11800			
MAX. LIFTING HEIGHT FROM CRANE BASE	ft	15' 11"	19' 2"	18' 4"	22' 5"
SUGGESTED OIL FLOW	gpm	3.9 – 4.8			
MAX. WORKING PRESSURE	p.s.i.	3336			
BASIC CRANE WEIGHT	lbs	1036	1124	1102	1212

WINCH SPECIFICATIONS	U.M.	
MAX. WINCH SINGLE LINE CAPACITY (3 rd LAYER)	lbs	2182 ("CE") 2204 (EXTRA "CE")
ROPE RAISING SPEED (3 rd LAYER)	ft/min	49.2
ROPE LOWERING SPEED (3 rd LAYER)	ft/min	65.6
ROPE DIAMETER	inches	5/16"
ROPE LENGTH	ft	98' 5"
WINCH KIT WEIGHT	lbs	165

OPERATING TIMES										
SLEWING (rpm)	LIFTING (sec)	LOWERING (sec)	EXTENSION OUT (sec)				EXTENSION IN (sec)			
			500.2C	500.3C	500.2L	500.3L	500.2C	500.3C	500.2L	500.3L
2.3	13	11	17	22	20	31	10	12	12	18

Winch versions: Maximum lifting capacity 2812 lbs ("CE" version) or 2204 lbs (EXTRA "CE" version), in single pull line, without strain limiting device; outreaches unchanged.

Stabilizers: Refer to models 1 EMO/1 EHO or 1 EMA/1 EHA on MAXISTAB catalogue.

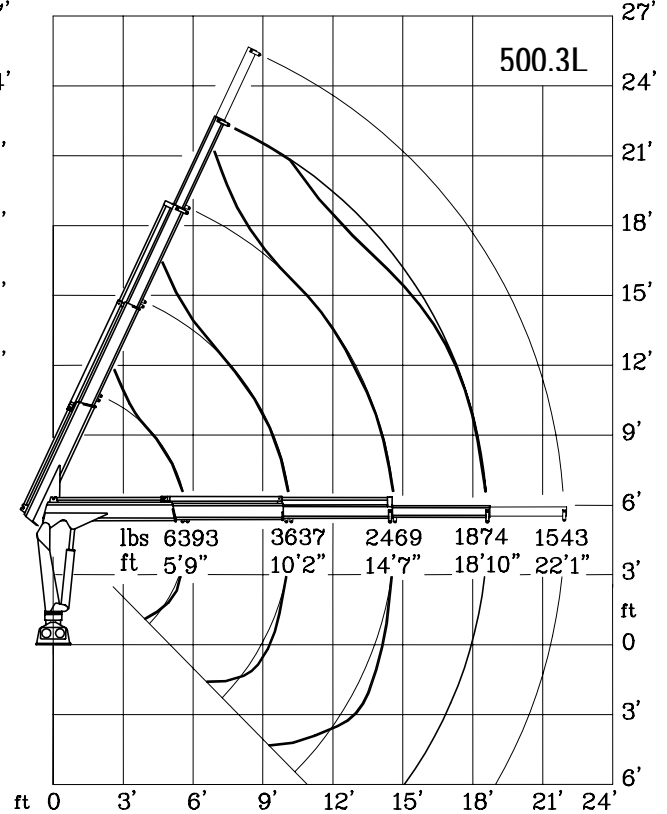
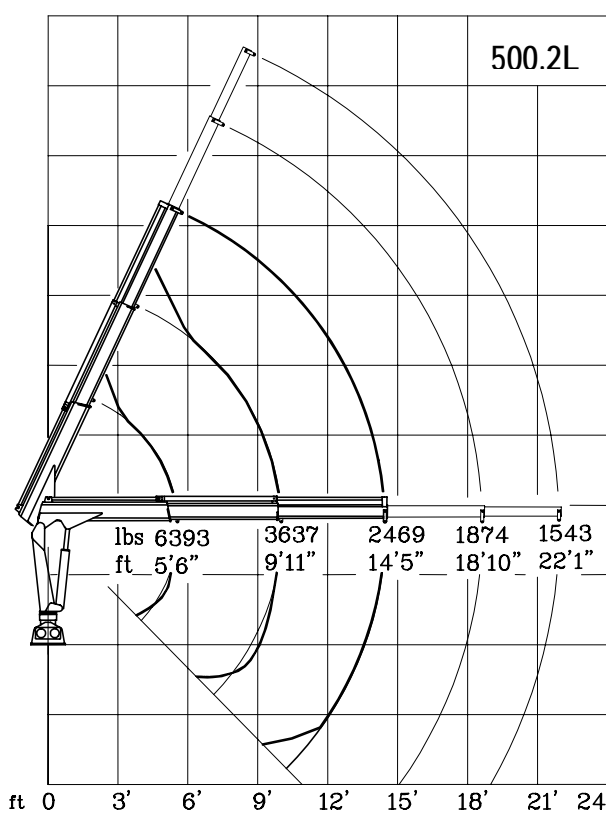
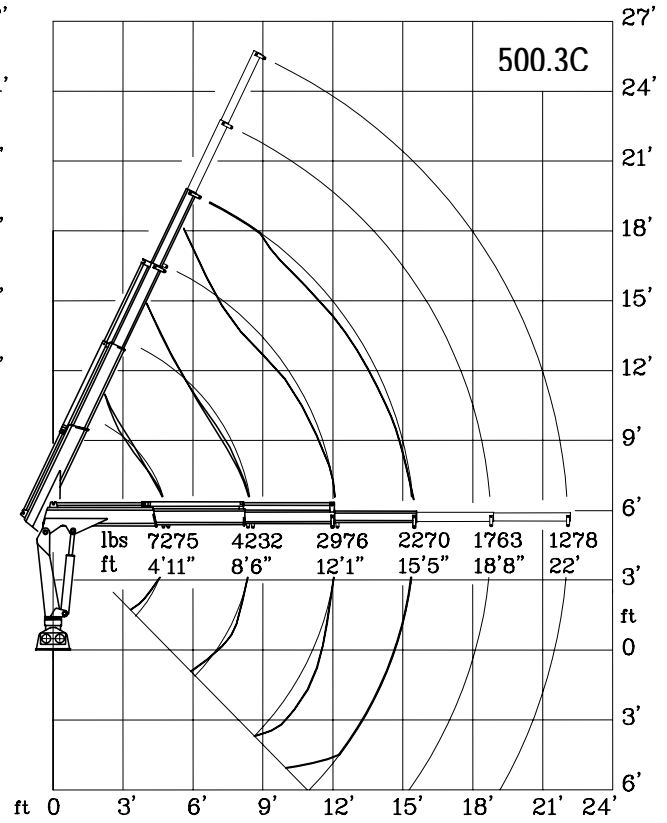
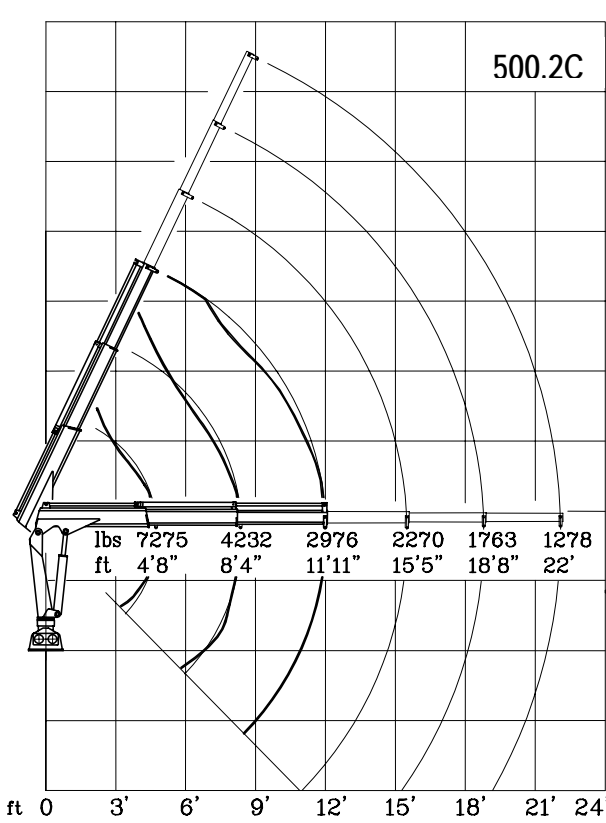

Classe sollev. **H2 - B3**
Lifting class **DIN 15018**



maxilift
by

Next Hydraulics



Via Mediterraneo n°6, 42022 Boretto (R.E.) Italy

Tel.: +39.0522.963008, Fax.: +39.0522.963039

<http://www.maxiliftcrane.com> E-mail: info@maxiliftcrane.com